



**ANNUAL STANDARDS AND SPECIFICATIONS
FOR
EROSION AND SEDIMENT CONTROL
AND
STORMWATER MANAGEMENT**

2018 Edition

Subject: GEORGE MASON UNIVERSITY ANNUAL STANDARDS AND SPECIFICATIONS FOR EROSION AND SEDIMENT CONTROL AND STORMWATER MANAGEMENT

Dated: April 24, 2018

I certify under penalty of law that all documents and all attachments related to the submission and updating of the GEORGE MASON UNIVERSITY ANNUAL STANDARDS AND SPECIFICATIONS FOR EROSION AND SEDIMENT CONTROL AND STORMWATER MANAGEMENT are prepared under my direction or supervision in a system designed to assure that qualified personnel properly gather and evaluate the information submitted. Based on my inquiry of the person or persons who manage the system or those persons directly responsible for gathering the information, the information submitted is to the best of my knowledge and belief true, accurate, and complete. I am aware that there are significant penalties for submitting false information including the possibility of a fine and imprisonment for knowing violations.

Sincerely,



Frank Strike, PE
Vice President, Facilities

INTRODUCTION

George Mason University (Mason) Erosion and Sediment Control (ESC) and Stormwater Management (SWM) Programs are integral components of Mason's design, construction, maintenance, and management of Mason's facilities and campuses. *George Mason University Annual Standards and Specifications for ESC and SWM* has been developed to provide information regarding Mason's implementation of these programs in accordance with Virginia Erosion and Sediment Control Law (§62.1-44.15:51 et seq.), the Virginia Erosion and Sediment Control Regulations (9VAC25-840 et seq.), the Virginia Stormwater Management Act (§62.1-44.15:24 et seq.), and the Virginia Stormwater Management Program (VSMP) Permit Regulations (9VAC25-870 et seq.) as related to municipal separate storm sewer systems and regulated construction activities.

George Mason University Annual Standards and Specifications for ESC and SWM shall apply to all plan design, construction, inspection, and maintenance activities undertaken by Mason, either by its internal workforce or contracted to external entities, where such activities are regulated by the Virginia Erosion and Sediment Control Law and Regulations (VESCL&R), and/or the Virginia Stormwater Management Act, and/or the VSMP Permit Regulations. During inspections of George Mason University's land disturbing activities by Mason Civil and Environmental Engineering Division, Virginia Department of Environmental Quality (DEQ), Environmental Protection Agency (EPA), and other applicable environmental agencies, compliance with the approved *George Mason University Annual Standards and Specifications for ESC and SWM* (and all parts thereof), the VESCL&R, the Virginia Stormwater Management Act, and the VSMP Permit Regulations will be required.

George Mason University Annual Standards and Specifications for ESC and SWM are submitted to Virginia DEQ for review and approval on an annual basis. Mason shall ensure that project specific plans are developed and implemented in accordance with the Annual Standards and Specifications. This submittal constitutes Mason's commitment to execute all provisions contained herein on the regulated land disturbing activities and land development projects. As such, this submittal will be made available and utilized as an operational guidance by all appropriate Mason and DEQ personnel. This submittal and errata information are available for download as PDF files at: <http://facilities.gmu.edu/>

TABLE OF CONTENTS

APPENDICES	ii
ABBREVIATIONS and ACRONYMS	iii
1. ANNUAL STANDARDS AND SPECIFICATIONS ADMINISTRATION	1
2. ANNUAL STANDARDS AND SPECIFICATIONS PERSONNEL	2
3. ANNUAL STANDARDS AND SPECIFICATIONS IMPLEMENTATION	3
4. ESC AND SWM PLAN REQUIREMENTS	5
5. INSPECTIONS	5
6. VARIANCES AND EXCEPTIONS.....	6
7. PROJECT TRACKING AND NOTIFICATION	7
8. CONSTRUCTION REQUIREMENTS	7
9. PERFORMANCE WARRANTY	8
10. LONG - TERM MAINTENANCE	8
11. ANNUAL REVIEW AND EVALUATION.....	8

APPENDICES

Appendix – A: Current and Future Land Disturbing Activities

Appendix – B: Land Disturbance Application Form

Appendix – C: Land Disturbance Permit

Appendix – D: Plan Review Checklist

Appendix – E: Environmental Compliance Report

Appendix – F: Notice of Termination

Appendix – G: Variance Request Form

Appendix – H: Erosion and Sediment Control Structures

Appendix H.1: SILTSACK® Specification

Appendix H.2: GUTTERBUDDY® Specification

Appendix H.3: FILTERBAG Specification

Appendix H.4: FILTER FABRIC Specification

Appendix H.5: Super Silt Fence

Appendix H.6: INLET MARKINGS Specification

Appendix H.7: CONCRETE WASHOUT Specification

Appendix H.8: PERMANENT CHECK DAM Specification

Appendix H.9: GutterGator Specification

Appendix – I: Specifications

Appendix I.1: Planting Soil Specification

Appendix I.2: Turf and Grasses Specification

Appendix I.3: TV Specification

ABBREVIATIONS AND ACRONYMS

Abbreviation/ Acronym	Term
BMP	Best Management Practice
Board	Virginia State Water Control Board
DEQ	Virginia Department of Environmental Quality
ESC	Erosion and Sediment Control
LID	Low-Impact Development
Mason LD	George Mason University Land Development Division
MS4	Municipal Small Storm Sewer System
NLDPP	Mason Land Development How-To Guide: Navigating the Land Disturbance Permitting Process
SWM	Stormwater Management
SWPPP	Storm Water Pollution Protection Plan
VESCL&R	Virginia Erosion and Sediment Control Law and Regulations
VSMP	Virginia Stormwater Management Program

1. ANNUAL STANDARDS AND SPECIFICATIONS ADMINISTRATION

1.1. George Mason University (Mason) follows the policies and procedures described in the Virginia Erosion and Sediment Control Handbook and the Virginia Stormwater Management Handbook. *George Mason University Annual Standards and Specifications for ESC and SWM* approved by DEQ are composed of general specifications. The general specifications for erosion and sediment control and storm water management that apply to land-disturbing activities include by reference the following:

- Virginia Stormwater Management Act (§62.1-44.15:24-50)
- Virginia Stormwater Management Program (VSMP) Regulations (9VAC25-870)
- General Permit for Discharges of Stormwater from Construction Activities (9VAC25-880)
- General Permit for Discharges of Stormwater from Small MS4s (9VAC25-890)
- Virginia Erosion and Sediment Control Law (§62.1-44.15:51-66)
- Virginia Erosion and Sediment Control Regulations (9VAC25-840)
- Virginia Erosion and Sediment Control Certification Regulations (9VAC25-850)
- Virginia Erosion and Sediment Control Handbook, 1992
- Virginia Stormwater Management Handbook, 1999, as amended.
- Virginia Stormwater BMP Clearinghouse (<http://www.vwrrc.vt.edu/swc/>)
- Technical Bulletins, as amended,
<http://www.deq.virginia.gov/Programs/Water/StormwaterManagement/Publications.aspx>
- *Mason Land Development How-To Guide: Navigating the Land Disturbance Permitting Process (NLDPP)*

1.2. All plan design, construction, and maintenance activities undertaken by Mason, either by its internal workforce or contracted to external entities, shall comply with *George Mason University Annual Standards and Specifications for ESC and SWM*.

1.3. All land disturbing activities, as defined by *VSMP*, shall be vetted through Mason LD. A Land Disturbance Application (Appendix B) shall be completed and submitted to Mason LD with a construction schematic and locations of the proposed work. Prior to starting a land-disturbing project, the project must have a Mason Land Disturbance Permit issued by Mason LD if disturbing activities more than 2,500 square feet (Appendix C) , and [Construction General Permit](#) issued by DEQ if disturbing activities more than one acre

1.4. Site-Specific ESC, SWM, and Stormwater Pollution Prevention Plan (SWPPP) shall be prepared for all projects involving a regulated land-disturbing activity as defined in §62.1-44.15:24 or when deemed necessary by Mason LD. Site-specific ESC, SWM and SWPPP plans shall be submitted to Mason LD for review and approval.

1.5. A responsible Land Disturber (RLD) shall be designated prior to initiating any land-disturbing activity. Mason shall notify the DEQ of the RLD at least two weeks in advance of the land-disturbing activity. The information provided shall include the name, contact information, and certification number of the

RLD. RLD is responsible to obtain proper permits for offsite/borrow areas, if necessary.

2. ANNUAL STANDARDS AND SPECIFICATIONS PERSONNEL

DEQ is the permit issuing authority for Construction General Permit. Mason LD shall be the authority for administrating Mason land-disturbing projects under *George Mason University Annual Standards and Specifications for ESC and SWM*. The following is a breakdown in responsibilities and titles in regard to *George Mason University Annual Standards and Specifications for ESC and SWM*. Responsibilities may be combined in terms of staffing resources only if the person responsible for the task(s) is qualified per Section 2.5. The following titles are designated to ensure compliance with *George Mason University Annual Standards and Specifications for ESC and SWM* on Mason land-disturbing projects.

- 2.1. Certified Program Administrator is an employee of Mason LD who: (i) holds a certificate of competence from the Board in the area of program administration; or, (ii) is enrolled in the Board's training programs for the program administrator and successfully completes such programs within two years after enrollment.

This position shall oversee the overall management for George Mason University Annual Standards and Specifications for ESC and SWM program; and (ii) shall update the George Mason University Annual Standards and Specifications for ESC and SWM annually.

- 2.2. Certified ESC/SWM Inspector is an employee or agent of Mason LD who: (i) holds a certificate of competence from the Board in the area of ESC/SWM inspection; or, (ii) is enrolled in the Board's training program for ESC/SWM inspection and successfully completes such program within two years after enrollment.

This position (i) shall be responsible to inspect as mandated by the VESCL&R erosion and sediment control measures to ensure proper installation in accordance with the permitted plans and effectiveness of such measures in an effort to maximize site erosion and sediment control; and/or, (ii) shall be responsible to inspect the construction and effectiveness of permanent stormwater management controls; and/or (iii) shall be responsible to inspect the stormwater pollution prevention measures that must take place during construction; and, (iv) shall be responsible to verify that all required documents are available on-site for view/review, including but not limited to, land disturbance permit, permitted plans, inspections log, VSMP permits, and SWPPP documents..

- 2.3. Certified ESC Plan Reviewer is an employee or agent of Mason LD who: (i) holds a certificate of competence from the Board in the area of plan review; or, (ii) is enrolled in the Board's training program for project inspection and successfully completes such program within two years after enrollment; or, (iii) is licensed as a professional engineer, architect, certified landscape architect, or land surveyor pursuant to Article 1 (§54.1-400 et seq.) of Chapter 4 or Title 54.1 of the Code of Virginia or as a professional soil scientist as defined in Chapter 22 (§ 54.1-2200 et seq.) of Title 54.1 of the Code of Virginia that qualifies as a certified plan reviewer for ESC.

This position (i) shall be responsible to review and permit ESC plans in compliance with *George Mason University Annual Standards and Specifications for ESC and SWM* and applicable ESC laws and regulations; and, (ii) can assume the role of inspector or assist with inspections when needed.

- 2.4. Certified SWM Plan Reviewer is an employee or agent of Mason LD who: (i) holds a certificate of competence from the Board in the area of plan review; or, (ii) is enrolled in the Board’s training program for project inspection and successfully completes such program within two years after enrollment.

This position (i) shall be responsible to review and permit SWM plans in compliance with *George Mason University Annual Standards and Specifications for ESC and SWM* and applicable SWM laws and regulations; and, (ii) shall be responsible to review and approve SWPPPs; and, (iii) can assume the role of inspector or assist with inspections when needed.

- 2.5. Certified Combined Program Administrator is an employee of Mason LD who: (i) holds a certificate of competence from the Board in the combined areas of program administration, plan review, and project inspection; or, (ii) is enrolled in the Board’s training program for the program administrator, plan reviewer, and project inspection and successfully completes such program within two years after enrollment.

This position (i) shall oversee all of the inspection and plan review personnel; and, (ii) shall designate the Inspectors and Plan Reviewer; and, (iii) shall directly communicate with the Contractor and DEQ when circumstances require enforcement actions; and, (iv) shall oversee the update of the *George Mason University Annual Standards and Specifications for ESC and SWM*; and, (v) is DEQ’s delegated permitting authority.

- 2.6. Certifications shall be in accordance with the Virginia Erosion and Sediment Control and Stormwater Management Certification Regulations (9VAC25-850-40).

3. ANNUAL STANDARDS AND SPECIFICATIONS IMPLEMENTATION

3.1. Submittals

ESC, SWM, and SWPPP plans, narratives, and necessary attachments shall be submitted to the Mason LD for review and approval prior to any land-disturbing activities. The required elements for various submittal phases can be found in Appendix D: *Plan Review Completion Checklist*. Final submittals for land-disturbing projects including infrastructure/utility work shall include hardcopy, electronic copy (PDF), and CAD drawings. CAD drawings shall conform to National CAD Standard regarding layers, plot styles, line types, etc.

As-built drawings shall be submitted in order to close out the Mason Land Disturbance permits. See section 5.2 for additional information.

3.2. Plan Reviews

Plan reviews shall be conducted by qualified personnel defined in Section 2. Plan review shall ensure compliance with the *George Mason University Annual Specifications for ESC and SWM*. Plan reviewers shall use the *Plan Review Checklist* (Appendix D).

After receiving the submittals, the Mason LD shall have 15 calendar days to determine completeness of the plan(s) and notify in writing. The Mason LD shall have additional 60 calendar days from the time of notification to review the plan(s) and provide written comments.

If re-submission to review, the Mason LD shall have 45 calendar days to review and respond in writing to previously disapproved plan(s). Re-submission should include one (1) red-lined plan set of the first submission showing all to-date revisions and at least one (1) clean, updated plan set.

When approved, at least three (3) unmarked, updated plan sets, stamped by a licensed professional engineer, architect, certified landscape architect, or land surveyor in Virginia, must be submitted to Mason LD. These plan sets are allocated as follows: 1) for Records, (1) for the Project Inspector and (1) for the Contractor. Additional copies may be requested as needed. Electronic copy (PDF) and CAD drawings are also required to be submitted to Mason LD.

Prior to commencement of a land-disturbing project, the project must have received approval for the plan(s) from Mason LD. Mason LD shall have 60 calendar days to review and provide written comments to modifications to approved plan(s).

Plan Reviews are not to be used to evaluate design concepts. Pre-design concept meetings are strongly encouraged.

3.3. Inspections

The certified inspector(s) is responsible for ensuring that the construction and installation of all structural and non-structural controls are in accordance with the project's ESC, SWM, and SWPPP plans and intention. In addition, if circumstances arise where the current plan is proven inadequate to provide necessary protection and needs additional engineering evaluation, the inspector is responsible to notify Mason LD, who shall take the necessary steps to coordinate with the Contractor and Engineer to address and resolve the issue. Inspectors are responsible to complete and submit Environmental Compliance Report (Appendix E). Refer to Section 5.0 for more information on inspections.

3.4. Changes and Amendments to Approved Plans

An approved plan may be changed by Mason LD in the following cases:

- (i) Where inspection has revealed the plan is inadequate to satisfy applicable laws and regulations;
or
- (ii) Where the person responsible for carrying out the approved plan finds that such plan is no longer effective due to field conditions and/or changes to the overall project scope. In such case, an amended plan, consistent with the requirements of this document, must be promptly proposed.

Revisions to an approved ESC, SWM and/or SWPPP plan must be submitted in writing to the Mason LD. Formal plan revisions are only necessary when the changes involve activities such as changing disturbance areas, engineered controls (e.g., a sediment trap or basin), or a revision in the level/quantity

of ESC and/or SWM measures. Revisions shall not be considered approved until written notification by Mason LD is provided. All revisions must be clouded in red. Revisions must comply with the *George Mason University Annual Standards and Specifications for ESC and SWM*. Exceptions may be allowed in the event of an emergency.

The Contractor is responsible for the performance of the ESC/SWM measures. If the designated ESC/SWM proves to be inadequate, the Contractor is responsible to reassess, design, and submit a plan amendment at no cost to Mason.

4. ESC AND SWM PLAN REQUIREMENTS

Detailed requirements of specific items to be included in the ESC and SWM plans can be found in the Plan Reviewer Checklist (Appendix D).

Individual plans, to the maximum extent practicable, shall comply with any locality's VSMP authority's technical requirements adopted pursuant to Virginia Stormwater Management Act. It shall be the responsibility of Mason to demonstrate that the locality's VSMP authority's technical requirements are not practicable for the project under consideration.

At the completion of a project, as-built drawings, including permanent SWM facilities shall be provided to Mason LD bearing the seal and signature of a Virginia registered professional Engineer or Land Surveyor, certifying that the site, including SWM facilities, has been constructed in accordance with the approved plan. As-built drawings shall be provided in both PDF and CAD format. The licensed professional shall provide surveys, photographs, construction logs, inspection reports, geotechnical testing reports, soil reports, certification of materials, and all other applicable information documentation.

5. INSPECTIONS

In lieu of an approved alternative inspection program, inspections shall be conducted, at a minimum, every two weeks and within 48 hours of a significant rainfall event producing runoff. Mason's ESC/SWM Inspectors shall be notified 24 hours prior to installation of BMPs and shall be present for installation of BMPs. In addition, inspections shall be made during or immediately following initial installation of erosion and sediment controls and at the completion of the project. Completion of the project is defined as the achievement of final stabilization, not completion of construction.

5.1. SWPPP Inspections

The Environmental Compliance Report, provided in Appendix E, shall be used on each site inspection visit during construction. All SWPPP measures, including ESC, SWM, and Pollution Prevention, shown on the plan shall be inspected. All issues and violations shall be photographed and documented in the *Environmental Compliance Report*, where required corrective action for each issue or violation shall be specified and a date by which all corrective actions must be completed. Critical areas that require continuous inspections shall also be identified on the site plan. A copy of the *Environmental Compliance Report* shall be sent to the Contractor, Project Managers, Mason LD and other responsible parties.

5.2. Project Close-Out Inspection

Project completion is defined as the achievement of final stabilization, verification of final product according to approved plans, completion of TV inspection (Refer to Appendix I.3) of the installed storm sewer system, if deemed necessary by Mason LD, and submittal of as-built drawings . The inspector will determine that final stabilization has been achieved. Once Mason LD concurs, final project as built and Mason Land Disturbance Permit Notice of Termination are submitted to Mason LD by the Contractor, the Land Disturbance Permit will be closed-out and the Construction GP terminated by DEQ. The contractor is responsible to submit the VSMP General Permit Notice of Termination Form to DEQ before the Land Disturbance Permit be closed out. After which, Mason LD may recommend that full retainage be released. If deemed appropriate, retainage may be withheld as a performance guarantee for up to 60 calendar days after achievement of final stabilization unless otherwise directed by the Contract. Full retainage may not be released without recommendation by the Mason LD.

5.3. Post-construction Inspections

Post-construction (long-term) inspections shall be made in accordance with the manufactures' and/or engineer's recommendation, the provisions of these standards and specifications, and the general specifications provided in Section 1.1, including Virginia Stormwater BMP clearinghouse, SMW Handbook, and 9VAC25-870-112 and -200B. Inspections shall be conducted annually and/or after any storm which causes the capacity of the facility's principle spillway to be exceeded.

5.4. Violations and Documentation

Violations shall be documented in the *Environmental Compliance Report*, including photographs, descriptions, and necessary corrective actions. If a violation continues to be repeated, a formal Notice of Comply will be issued, and DEQ Woodbridge Office will be notified. At the discretion of Mason LD, the Land Disturbance Permit may be suspended and/or revoked; at which time all land disturbing activities must cease until the violation(s) of the plan or permit has ceased, corrective action completed, and any related environmental or property damages abated. Mason LD reserves the right to contract with a 3rd party to install and maintain the ESC/SWM measures in accordance with the approved plan, complete any necessary corrective actions, and abate any related damages. Once the site is stabilized to the satisfaction of the Mason LD, site work may resume. All associated costs will be back-charged to the Contractor.

6. VARIANCES AND EXCEPTIONS

Variations and exceptions to regulations must ensure protection of off-site properties and resources from damage. Economic hardship is not a sufficient reason to request a variance or an exception from *VSMP* or *George Mason University Annual Standards and Specifications for ESC and SWM*. Variations and exceptions are considered to be project specific.

6.1. Variance or Exception Request Policy and Procedures:

- The design professional shall submit a written request to Mason LD to request project specific variations to *George Mason University Annual Standards and Specifications for ESC and SWM* and shall be accompanied by complete details and documentation, including justification and impacts associated with the request (Appendix G). The request shall include an explanation and description

of the specific condition necessitating the request. The request shall include a detailed description of the alternative practice and justification that the practice meets the intent of the regulation for which the variance is sought.

- If determined to be appropriate by Mason LD in accordance with 9VAC25-840-50 or 9VAC25-870-122, the Program Administrator will send the variance/exception request to DEQ Central Office for review and approval.
- All requests shall be considered unapproved until written approval from DEQ is received (A period of thirty days shall be scheduled for this request).
- All approved variances or exceptions shall be listed in the General Notes section of the ESC & SWM plans for land disturbing activities and included in the Narrative.

7. PROJECT TRACKING AND NOTIFICATION

7.1. Future Land-disturbing Activities

A list of regulated land-disturbing activities expected to soon be under contract is included in Appendix A. The list includes project location, estimated disturbed acreage, and approximate start and completion date for each project.

7.2. Current Land-disturbing Activities

A list of current permitted land-disturbing activities during the referenced time period is included in Appendix A. The list includes project location, project start and completion date, and actual disturbed area.

7.3. Project Tracking and Notification

- Mason LD will use GIS to track regulated land-disturbing activities.
- Mason LD will update the GIS map as necessary with project information as related to ESC and SWM.
- The GIS map will be accessible through an internet web browser or an email notification to DEQ if changes are made to the previous map.

7.4. Responsible Land Disturber

Mason LD shall notify the DEQ of the Responsible Land Disturber (RLD) at least two weeks in advance of land-disturbing Activities. The information to be provided shall include the project name, project location, project manager contact information, certification number and contact information of the RLD, project description, acreage of disturbance for project, project start and finish date, and any variance/waivers/exemptions associated with the project. Mason will utilize DEQ's e-notification system when it is available.

8. CONSTRUCTION REQUIREMENTS

8.1. Top Soil

All area that is disturbed shall require a minimum top soil depth of 2" in grassed areas and 4" in landscaped areas. Refer to Appendix I.1 for additional requirements on top soil.

8.2. Construction Area Maintenance

All grassed perimeter areas shall be mowed at least once a month during construction in order to maintain the aesthetics of the University.

8.3. Stabilization

Turf and grasses shall comply with the requirements in Appendix I.2. In the event that approved seeding does not establish stabilization within 90 calendar days of installation, sod shall be installed at no expense to Mason.

9. PERFORMANCE WARRANTY

- Upon termination of the permit, the Contractor shall warranty all work, including but not limited to, storm sewer and BMP facilities installations, landscaping, turf, etc. for one year from the date of the substantial completion.
- In the event that such feature does not meet its designed and approved intent, the Contractor shall repair/replace the feature in kind per the Standards and Specifications outlined in this document at no expense to Mason.
- The repair/replacement shall be guaranteed to perform as designed for one year from the date of repair acceptance.

10. LONG-TERM MAINTENANCE

Project plans shall contain information on long-term inspection and maintenance of permanent BMP facilities. Mason Facilities Management is responsible for BMP maintenance and repair. Post-construction inspections will be conducted in accordance with Section 5.0. Inspectors shall inspect and note items from the stormwater management devices that were identified for cleaning or repair. The inspection results shall be provided to the Program Administrator for recordkeeping and for assistance with the issuance of a work order to complete the activity.

Mason LD plans to use GIS to track SWM facilities and associated watersheds. The Mason LD BMP GIS map will be updated quarterly with information as related BMPs. The GIS map is available upon request.

11. ANNUAL REVIEW AND EVALUATION

11.1. DEQ's Responsibilities

DEQ shall have sixty days in which to comment on any ESC/SWM specifications submitted for review, and its comments shall be binding on Mason LD and any private business hired by Mason LD.

Enforcement of *George Mason University Annual Standards and Specifications for ESC and SWM* shall be administered by DEQ and the Board where applicable in accordance with the provisions of § 62.1-44.15:27.F, § 62.1-44.15.54E, § 62.1-44.15:56G.

The DEQ shall perform random site inspections or inspections in response to a complaint to assure compliance with the article § 62.1-44.15:31C, the Erosion and Sediment Control Law (§ 62.1-44.15:51),

and regulations adopted thereunder.

DEQ shall assess an administrative charge to cover the costs of services rendered associated with its responsibilities pursuant to § 62.1-44.15:31D and § 62.1-44.15:55D.

DEQ might request additional information from Mason, including:

- Inspection reports conducted by GMU as well as complaint logs and complaint responses.
- GMU may be required to provide weekly e-reporting to the department's applicable regional office, including inspection reports; pictures; complaint logs and complaint responses; and other compliance documents.

11.2. Mason's Responsibilities

Mason LD shall ensure compliance with the approved plan and annual standards and specifications. Upon request by DEQ, Mason shall provide a copy of the approved plan sheets and narrative for each regulated land-disturbing activity as outlined in Section 1. Mason LD shall provide DEQ with the appropriate information, in a timely manner, when requested.

APPENDIX A:

Current and Future Land Disturbing Activities

A project tracking list will be submitted separately.

APPENDIX B:

Land Disturbance Application Form



LAND DISTURBANCE PERMIT APPLICATION

University Administrator
Zhongyan (Jane) Xu 703-993-4051

Date: _____

Applicant:² _____ Contact #: _____
Address: _____

Contractor:² _____ Contact #: _____
Address: _____

Responsible Land Disturber: _____ Contact #: _____
RLD Certificate Number: _____

Project: _____
Project Number (if applicable):³ _____ Campus:⁴ _____
Project Description:⁵ _____

Start Date: _____ Completion Date: _____

Documentation Included:

Drawings⁶ E&S Checklist⁷ SWPPP⁸ Stormwater Plan⁹

Other: _____

Proposed Increase of Impervious Area: _____ square feet¹⁰
Proposed Reduction of Impervious Area: _____ square feet¹¹

Type of Review:

Land Development¹² Erosion & Sediment Control¹³ Stormwater Design¹⁴

Note: Completed Drawings must be included for all reviews. A completed ESC Checklist and Stormwater Concept Plan must be included for Erosion & Sediment Control Review. A completed SWPPP must be included for Stormwater Design Review. All required documents must be included or it will not be reviewed.

APPENDIX C:

Land Disturbance Permit



George Mason University Land Development
4400 University Drive MS 2C1, Fairfax, Va, 22030
email: masonld@gmu.edu

PERMIT

Annual Standards and Specifications Edition:

Land Disturbance Permit #:

Erosion and Sediment Control Permit #: Phase 1 Phase 2

Stormwater Management Permit #:

Campus: Project:

Approval Date: Approved By:

Responsible Land Disturber: Certificate #:

Referenced Documents: Application Date:

Drawings Dated: Other:

SWPPP Dated:

N O T I C E

The permit authorizes the Contractor to the impervious area within the approved Limits of Construction. This represents a cumulative .

Any further increase in impervious area must be submitted for review and approval to George Mason University Land Development Authority.

Issuance of a permit does not indicate approval of site utilities. A separate building permit for the site utilities is required. This permit will be issued by BCOM.

Comments:

Signature: *Z Xu*
Date: 07/21/2016

APPENDIX D:

Plan Review Checklist



COMPLETION CHECKLIST FOR EROSION AND SEDIMENT CONTROL AND STORMWATER MANAGEMENT PLAN

Project Name: _____ Receipt Date: _____
 Drawing Date: _____ Phone Number: _____
 Architect/ Engineer: _____
 Are all of the following submitted? Yes No Check all that is submitted.

Schematic (50%)
 Interim (70%)
 Final (100%)

- Cover Sheet
- General Construction Details
- Demolition Plan
- Existing Conditions and Grading
- Existing Drainage Divides
- Proposed Site Plan Layout
- Proposed Grading Plan
- Proposed Drainage Divides
- E&S Narrative
 - Project Description
 - Existing site Conditions
 - Adjacent Properties
 - Off-site Areas
 - Soils
 - Critical Areas
 - Erosion and Sediment Control Measures
 - Permanent Stabilization
 - Stormwater Runoff Considerations
 - Calculations(Pre and Post Runoff, temporary and permanent practices computations,etc.)
 - Maintenance
- Phase 1 E&S w/Drainage Divides
- Phase 2 E&S w/Drainage Divides
- E&S Details
- Stormwater Quality computations N/A
- Stormwater Quantity Computations N/A
- Stormwater Details and Specifications N/A
- Stormwater Pipe Profiles N/A
- Stormwater Calculations N/A
- Detailed Landscaping plan N/A
- PE Signature
- Mason Land Disturbance Permit Application N/A
- VSMP Registration Form N/A
- Other Permits
 - Virginia Water Protection Permit (VWPP) N/A
 - Department of Historic Resources (DHR) N/A
 - Virginia Department of Health (VDH) N/A
 - Virginia Department of Transportation (VDOT) N/A
 - Permits from localities N/A
 - Others N/A
- Environmental Impact Review (EIR) N/A
- Geotechnical Report N/A
- Stormwater Pollution Prevention Plan (SWPPP) N/A

Comments:
 Please submit the unchecked items to Mason PM&C Office or masonld@gmu.edu to continue the review.
 Disclaimer: By providing the required documentation above, you guarantee that checked items had been through QA/QC process before submission.

Reviewer/Date: _____

DESCRIPTIONS

Cover Sheet: Includes general notes; soil maps and soil data tables with soil name, mapping unit, K-factor (erodibility), permeability, depth, texture, and soil structure, and a vicinity map that shows the general location of the project in relation to roads and topography.

General Construction Details: Any practices used other than ESC measures should be illustrated with detailed drawings

Existing Conditions and Grading: The existing property lines, land use, contours and features of the site such as roads, utilities, easement, etc. Includes dashed light lines for contours in intervals of 1 to 2 feet; environmental sensitive areas such as wetland, lakes, ponds, resources protection areas (RPA), existing tree lines; grassed areas or unique vegetation; potential critical areas (slopes); streams; swales and onsite and adjacent impaired waters.

Existing Drainage Divides: Dividing lines and the direction of flow for the pre-development drainage areas. It includes drainage areas (acres) and C-value for on-site and off-site areas.

Demolition Plan: This plan illustrates the existing conditions with the marked areas and/or features to be demolished or removed per construction sequence such as roads, sidewalks, curbs, buildings, trees, light poles. It shall outline the areas of disturbance.

Proposed Site Plan Layout: Refers to top view of a property that is drawn to scale. It should include the following: limit of the disturbance, SWM facilities; outline of existing and proposed buildings and structures; property lines, distance between buildings; distance between buildings and property lines (setbacks); parking lots indicating parking spaces; streets/trails/driveways; landscaped/vegetated areas; utilities, easements; etc.

Proposed Grading Plan: Changes made to the existing site contours should be shown as heavy solid lines with 1' – 2' intervals; spot elevations at high/low points and entrances; limits of disturbance; cut and fill information; steep slope information.

Proposed Drainage Divides: Dividing lines and the direction of flow for post-development drainage areas. It includes: drainage areas (acres) and C-value for on-site and off-site areas.

ESC Narrative: All plans must have Erosion and Sediment Control (ESC) Narrative. The narrative should be site specific and include the following items:

Project Description: This section should briefly describe the nature and purpose of the land-disturbing activity and the area (acres) to be disturbed. It also includes: project duration, pre and post impervious areas.

Existing Site Conditions: This section should provide a description of the existing features, topography, vegetation and drainage pattern of the site.

Adjacent Properties: Includes a description of neighboring areas such as streams, lakes, residential areas, roads etc., which might be affected by the land disturbance. Discuss any potential problem(s) that may be faced during and after construction. For instance: traffic, dust, increasing runoff.

Off-site Areas: This section should describe an off-site land-disturbing activities that will occur including borrow sites, stockpiles, etc. Includes responsible party of offsite areas.

Soils: This section should provide or refer to a brief description of the soils on the site giving such information as soil name, mapping unit, k factor (erodibility), permeability, depth, texture, and soil structure. Provides copy of the soils map.

Critical Areas: This section should provide a description of areas of the site which have potentially serious problems (steep slopes, channels, wetland, RPA, wet weather/underground springs, etc.). Includes areas to be left alone until they can be worked in favorable conditions and describes the construction sequence or other related issues to follow while working on them.

Erosion and Sediment Control Measures: This section should provide a list and description of the methods which will be used to control erosion and sedimentation on the site (Chapter III VESCH and Mason annual Standards and Specifications for ESC and SWM)

Permanent Stabilization: This section should provide description, including seeding specifications, of how the site will be stabilized after construction is completed. Shall list timing of seeding and describe areas to be stabilized with vegetation, mulch, etc.

Stormwater Runoff Considerations: This section should address the question if the development site will cause an increase in peak runoff rates during construction; and if the increase in runoff will cause flooding or channel degradation downstream. It should also provide a description of the strategy to control stormwater runoff.

Calculations: This section should provide detailed calculations for the design of temporary sediment basins, diversions, channels, etc.

Maintenance: A schedule of regular maintenance, inspection and repair of ESC structures should be set forth in this section.

Phase I ESC w/Drainage Divides: The location of ESC and SWM practices used on site per construction sequence. Standard symbols and abbreviations in Chapter 3 of the VESCH should be used to indicate: the exact locations of all practices including vegetation and legends denoting symbols.

Phase II ESC w/Drainage Divides: Same description as Phase I ESC w/Drainage Divides.

ESC Details; list of VESCH Chapter III-Minimum Standards; and General ESC notes: Any ESC measures used should be explained and illustrated with detail drawings. Moreover, details should be provided which are clearly dimensioned and reflected the ability to be "built" in the field according to the proper design criteria; provides scales for all drawings; all details should list specification number from the VESCH if applicable. List Minimum Standards 1-19 and General Notes for ESC (updated Table 6-1 VESCH).

Stormwater Quality Computations: Includes Virginia Runoff Reduction Method spreadsheet for Total Phosphorus (TP) removal required to be in compliance with water quality criteria for VSMP regulations.

Stormwater Quantity Computations: Include pre- and post-construction runoff calculations, adequate outfall calculations and Energy Balance Equation Method in order to comply with MS-19.

Stormwater Details and Specifications: Include type, size, grade, bedding material, compaction, WSEL, inverts and top elevations related to proposed stormwater facilities

Stormwater Pipe Profiles: Pipe profiles should be provided to verify storm sewer systems adequacy. These profiles should include size, materials, slopes, structure depth, invert elevations, top elevations, dimensioned utility crossings, and shown at a scale (V=1:5 H=1:25). Includes calculated design storm elevation profiles, energy grading line profiles, and hydraulic grading line profiles. Project specific profiles might be requested.

Stormwater Calculations: Provide calculations showing the adequacy of ditches, pipes, inlets, ponds and other stormwater system to handle design storm runoff without excessive velocities and overtopping. Dimensions of all storage areas should be checked.

Detailed Landscaping Plan: Landscaping plans and narratives with detailed planting schedule should be provided for stormwater control measures (ponds, bio-retention, etc.), site reforestation, revegetation and final stabilization.

PE Signature: Plans should be signed/stamped by a Professional Engineer, Architect or a Professional Land Surveyor.

VSMP Registration Form: Land disturbance equal or greater than one acre should submit a completed VSMP registration form for construction general permit.

Mason Land Disturbance Permit Application: This form must be completed and submitted to Mason LD for a land disturbance of any size.

Other Permits: All applicable federal, state and local regulations pertaining to construction activity must be met.

Virginia Water Protection Permit (VWPP) – This permit is required if surface water and/or wetlands are impacted during construction.

Department of Historic Resources (DHR): This permit is required if any the construction activity has any effects on historic sites/structures and cultural resources.

Virginia Department of Health (VDH): This permit is required if there are any potential impacts to public water distribution systems. Local Virginia Department of Health (VDH) and Office of Drinking Water (ODW) must be contacted. This permit is also required if construction or repair of any septic system or other onsite sewage disposal system is in the scope of construction.

Virginia Department of Transportation (VDOT): This permit is required if there are any potential impacts to existing and future transportation systems i.e. highway and road systems, rail, and public transportation systems. Land use permit from VDOT is required if activities other than travel on the commonwealth's highway systems that are under VDOT jurisdiction are conducted. These activities include but not limited to installation of utilities, construction of private and commercial entrances, landscaping and the temporary use of the right-of-way.

Environmental Impact Review (EIR): If applicable, a copy of the approved EIR shall be submitted to Mason LD with the plan.

Geotechnical Report: A copy of the geotechnical report with recommendations shall be submitted to Mason LD with the plan.

Stormwater Pollution Prevention Plan (SWPPP): A copy of the SWPPP shall be submitted to Mason LD for review. This is applicable for land disturbance areas equal or greater than 2500 square feet. Mason LD's SWPPP template is available electronically by request.

Reply To:
Facilities Construction Office
4400 University Dr. Fairfax, VA 22030
PHONE: (703) 993-4051
FAX: (703) 993-2524



CHECKLIST FOR AN EROSION AND SEDIMENT CONTROL PLAN PREPARATION AND REVIEW

1. Applicant Information

Final Plan Submission Date _____
 Project Name _____
 Site Plan/Permit Number _____
 Site Address _____
 Applicant _____ Phone Number _____
 Applicant Legal Address _____
 Owner _____ Phone Number _____
 Principal Designer _____ Phone Number _____
 General Contractor _____ Phone Number _____

2. **Signature and stamp of licensed professional consultant and owner certification**

3. Plan Status

Approved
 Not Approved

Legend: X - Complete
 Inc. - Incomplete/Incorrect
 N/A - Not Applicable

4. NARRATIVE

 N/A Project description:

- Briefly describes the nature and purpose of the land-disturbing activity.
- How many acres will be disturbed?
- How much impervious area will the project have in the post-development conditions?
- What are the ultimate developed conditions of the site?

 N/A Existing site conditions:

- Provide a description of the existing topography (list percentage of slopes on-site).
- Provide drainage area maps of the site in pre-development and post-development conditions.
- Discuss types of existing vegetation that can be used as erosion control, or areas that are to be left undisturbed and how they will be marked.
- Discuss any existing drainage or erosion problems and how they are to be corrected.

 N/A Adjacent areas:

- Provide a description of neighboring areas such as streams, lakes, CBPA Resource Protection Area (RPA), residential areas, roads, etc., which might be affected by the land disturbance.
- Streams that will receive runoff from the site should be surveyed to determine their carrying capacity.

 N/A Off-site areas:

- Describe any off-site land-disturbing activities that will occur (including borrow sites, waste or surplus areas, etc.).
- Will any other areas be disturbed?

Reply To:
Facilities Construction Office
4400 University Dr. Fairfax, VA 22030
PHONE: (703) 993-4051
FAX: (703) 993-2524



- N/A Soils:
- Provide a brief description of the soils on the site giving such information as soil name, mapping unit, erodibility (K factor), pH, permeability, depth, texture and soil structure.
 - Indicate references for soil information.
 - Provide copy of soil survey map.
- N/A Critical areas:
- Provide a description of areas on the site which have potentially serious erosion problems (e.g., steep slopes, channels, RPA, wet weather/ underground springs, etc.).
 - Discuss any area of the project which may become critical during the project.
- N/A Erosion and sediment control measures:
- Describe the methods which will be used to control erosion and sedimentation on the site.
 - List all controls used, list specification numbers in Chapter 3 of the Virginia Erosion and Sediment Control Handbook.
 - Discuss why control was selected and how it satisfies the applicable minimum standard(s).
 - Discuss sequence of installation, maintenance requirements and removal for each control selected.
 - Discuss Temporary Seeding as a means of erosion control, and list the types to be used.
- N/A Permanent stabilization:
- Provide a brief description, including specifications, of how the site will be stabilized after construction is completed. Seed specifications are to include type, and rate and time of application.
 - Include specifications for topsoil and seedbed preparation.
 - List the soil testing requirements.
 - Fertilizer and lime applications are to be in accordance with E&SC technical Bulletin #4. A copy of this bulletin is available at the link below:
<http://www.deq.state.va.us/Portals/0/DEQ/Water/Publications/ESCTechnicalBulletin4.pdf>
- N/A Stormwater runoff considerations:
- Will the development site cause an increase in peak runoff rates?
 - Will the increase in runoff cause flooding or channel degradation downstream? Discuss how downstream properties and waterways will be protected (basins, channel improvements, easements, etc.).
 - Describe the strategy to control stormwater runoff.
 - List or discuss all references for the design of permanent stormwater management facilities.
 - Have the possibilities of incorporating low impact development strategies for addressing stormwater management water quality and quantity requirements been investigated?
- N/A Calculations:
- Provide detailed calculations for the design of temporary sediment traps and basins, diversions, on-site and off-site channels, permanent stormwater facilities, etc.

Reply To:
Facilities Construction Office
4400 University Dr. Fairfax, VA 22030
PHONE: (703) 993-4051
FAX: (703) 993-2524



- Provide all calculations showing pre- and post-development runoff. Worksheets, assumptions and engineering decisions should be clearly presented.
- Calculations must show that downstream properties and waterways are adequately protected.

5. SITE PLAN

- N/A Vicinity map:
 - A small map locating the site in relation to the surrounding area. Include any landmarks which might assist in locating the site.
- N/A Indicate north:
 - Provide an arrow showing the direction of north in relation to the site.
- N/A Limits of clearing and grading:
 - Show all areas that will be cleared and graded.
 - Provide notes on how these areas will be marked.
 - Provide notes and illustrations that clearly indicate areas NOT to be disturbed.
- N/A Existing contours:
 - Provide a small-scale topographic map of the site showing the existing contours elevations at intervals of 1 to 5 feet depending on the slope of the terrain.
 - Should be shown as dashed light lines.
- N/A Final contours:
 - Show changes to the existing contours, including final drainage patterns.
 - Should be shown as heavy solid lines.
- N/A Existing vegetation:
 - Show the existing tree lines, grassed areas, or other unique vegetation.
- N/A Soils:
 - Show the boundaries of different soil types.
- N/A Existing drainage patterns:
 - Show the dividing lines for each drainage area and use arrows to show the direction of flow for the different drainage areas.
 - Include the size (acreage) of each drainage area.
 - All existing drainage swales and patterns on the site should be located and clearly marked on the topographic map.
 - Live or intermittent streams should be shown on the map.
- N/A Critical erosion areas:
 - All critical, environmentally sensitive, or prohibited areas are to be clearly shown on the plan with notes provided to state the critical nature.

Reply To:
Facilities Construction Office
4400 University Dr. Fairfax, VA 22030
PHONE: (703) 993-4051
FAX: (703) 993-2524



- N/A Site Development:
 - Show all improvements such as buildings, parking lots, access roads, easements, utility construction, etc.
- N/A Location of practices:
 - Show the locations of erosion and sediment control and stormwater management practices used on the site.
 - Symbols showing vegetation are also to be shown.
 - Use the standard symbols and abbreviations in Chapter 3 of the E&SC Handbook.
 - A legend denoting symbols, line uses, and other special characters is to be provided.
- N/A Off-site areas:
 - Identify any off-site land-disturbing activities (e.g., borrow sites, waste areas, etc.). Show location of erosion controls.
- N/A Detail drawings:
 - All structural practices used should be explained and illustrated with detail drawings.
 - All details should list the specification number from the VESCH.
 - Alternative E&SC measures must have proper drawings to indicate how and where they will be constructed.
 - All plan drawings, elevations, and cross-section drawings are to show the scales used to prepare the drawings.
 - A schedule of regular inspections and repair of each erosion and sediment control structure should be set forth including the maintenance items to check and perform as well as precautions for large storm events.
 - Outlet protection schedules are to be provided.
- N/A Maintenance:
 - A schedule of regular inspections and repair of erosion and sediment control structures should be set forth including the maintenance items to check and perform as well as precautions for large storm events.
 - List the person who is responsible during construction and who will be responsible once the project is complete.

6. MINIMUM STANDARDS

- N/A MS-1 – Temporary and permanent stabilization of denuded areas within 7 days
- N/A MS-2 – Protection or stabilization of on-site and off-site soil stockpiles and borrow areas

Reply To:
Facilities Construction Office
4400 University Dr, Fairfax, VA 22030
PHONE: (703) 993-4051
FAX: (703) 993-2524



- N/A MS-3 – Permanent vegetative stabilization of denuded areas not otherwise stabilized
- N/A MS-4 – Install erosion and sediment controls as the first step in land-disturbing activity
- N/A MS-5 – Earthen controls and structures stabilized immediately upon installation
- N/A MS-6 – Trap and Basin design
- Trap: < 3 acres total drainage area, 134 cubic yards per acre storage
- Basin: 3 acres or more total drainage area, 134 cubic yards per acre storage, safely handle a 25-year, 24-hour storm event
- N/A MS-7 – Design and construction of cut and fill slopes
- N/A MS-8 – Concentrated flow down cut and fill slopes
- N/A MS-9 – Slopes protected from seeps
- N/A MS-10 – Operational stormwater inlets must be protected
- N/A MS-11 – Outlets must be protected and stormwater conveyance channels stabilized before being made operational
- N/A MS-12 – Minimize impacts when working in and around live watercourses
- N/A MS-13 – Temporary vehicular stream crossings for more than 2 trips in 6 months
- N/A MS-14 – Other federal, state, and local regulations pertaining to work in live watercourses (Required permits COE, DEQ, VPDES, etc.)
- N/A MS-15 – Stabilize disturbed bed and banks of watercourses
- N/A MS-16 – Utility installations (< 500 feet open trench, stockpile upgradient, filter dewatering effluent, backfill and compact, other safety requirements)

Reply To:
Facilities Construction Office
4400 University Dr, Fairfax, VA 22030
PHONE: (703) 993-4051
FAX: (703) 993-2524



 N/A MS-17 – Keep paved or public areas clean

 N/A MS-18 – Remove temporary controls within 30 days when no longer needed

 N/A MS-19 – Address increases in stormwater volume, velocity, and peak runoff

Additional Notes:

Reviewed by:

Date:

Reply To:
Facilities Construction Office
4400 University Dr. Fairfax, VA 22030
PHONE: (703) 993-4051
FAX: (703) 993-2524



GENERAL EROSION AND SEDIMENT CONTROL NOTES

ES-1: Unless otherwise indicated, all vegetative and structural erosion and sediment control practices will be constructed and maintained according to minimum standards and specifications of the Virginia Erosion and Sediment Control Handbook, 1992 and the *Virginia Erosion and Sediment Control Regulations*.

ES-2: The Administrator must be notified one week prior to the pre-construction conference, two weeks prior to the commencement of land disturbing activity, and one week prior to the final inspection. The name of the Responsible Land Disturber must be provided to the Administrator two weeks prior to actual engagement in the land-disturbing activity shown on the approved plan. If the name is not provided prior to engaging in the land-disturbing activity, the plan's approval will be revoked.

ES-3: All erosion and sediment control measures are to be placed prior to or as the first step in clearing.

ES-4: A copy of the approved E&SC plan shall be maintained on the site at all times.

ES-5: Prior to commencing land disturbing activities in areas other than indicated on these plans (including, but not limited to, off-site borrow or waste areas), the contractor shall submit a supplementary E&SC plan to the Administrator for review and approval.

ES-6: The contractor is responsible for installation of any additional erosion control measures necessary to prevent erosion and sedimentation as determined by the Inspector.

ES-7: All disturbed areas are to drain to approved sediment control measures at all times during land disturbing activities and during site development until final stabilization is achieved, after which, upon approval by the Inspector, the controls shall be removed. Trapped sediment and the disturbed soil areas resulting from the removal of temporary measures shall be permanently stabilized to prevent further erosion and sedimentation.

ES-8: During dewatering operations, water shall be pumped into an approved filtering device.

ES-9: The contractor shall inspect all erosion control measures at least every 2 weeks and immediately after each runoff-producing rainfall event. Any necessary repairs or cleanup to maintain the effectiveness of the erosion control devices shall be made immediately.

Reply To:
Facilities Construction Office
4400 University Dr. Fairfax, VA 22030
PHONE: (703) 993-4051
FAX: (703) 993-2524



ES-10: The contractor is responsible for the daily removal of sediment that has been transported onto a paved or public road surface.

ES-11: Seeding operations shall be initiated within 7 days after reaching final grade or upon suspension of grading operations for anticipated duration of greater than 14 days or upon completion of grading operations for a specific area.

ES-12: The contractor shall be responsible for preventing surface and air movement of dust from exposed soils which may present health hazards, traffic safety problems, or harm animal or plant life.

ES-13: A Virginia Stormwater Management Program (VSMP) Permit for the discharge of stormwater from construction activities is required for projects disturbing 1 acre or greater. Visit DEQ's Construction General Permit web page at the following link for more information:
<http://www.deq.state.va.us/Programs/Water/StormwaterManagement/VSMPPermits/ConstructionGeneralPermit.aspx>

Reply To:
Facilities Construction Office
4400 University Dr. Fairfax, VA 22030
PHONE: (703) 993-4051
FAX: (703) 993-2524



**CHECKLIST FOR AN PRELIMINARY STORMWATER MANAGEMENT SITE PLAN
PREPARATION AND REVIEW**

1. Applicant Information

Initial/Preliminary Plan Submission Date _____
Project Name _____
Site Plan/Permit Number _____
Site Address _____
Applicant _____ Phone Number _____
Applicant Legal Address _____
Owner _____ Phone Number _____
Principal Designer _____ Phone Number _____
General Contractor _____ Phone Number _____

2. Plan Status

_____ Approved
_____ Not Approved

Legend: X - Complete
 Inc. - Incomplete/Incorrect
 N/A - Not Applicable

3. _____ Common address (with latitude and longitude coordinates or GPS position) and legal description of the site, including the tax reference number(s) and parcel number(s) of the property or properties affected.

4. Existing and proposed mapping and plans (recommended scale of 1" = 50', or greater detail), which illustrates the following at a minimum:

 N/A North arrow
 N/A Legend
 N/A Vicinity map
 N/A Existing and proposed topography (minimum of 2-foot contours recommended)
 N/A Property lines
 N/A Perennial and intermittent streams
 N/A Mapping of predominant soils from USDA soils surveys
 N/A Boundaries of existing predominant vegetation, areas of the site to be protected from disturbance, and proposed limits of clearing and grading
 N/A Location and boundaries of natural feature protection and conservation areas, such as wetlands, lakes, ponds, aquifers, public drinking water supplies, and applicable setbacks, etc.)
 N/A Identification of any on-site or adjacent water bodies included on the Virginia 303(d) list of impaired waters
 N/A Current and proposed land use and location of existing and proposed roads, buildings, parking lots and other impervious areas
 N/A Location and description of any planned demolition of existing structures, roads, etc.

Reply To:
Facilities Construction Office
4400 University Dr. Fairfax, VA 22030
PHONE: (703) 993-4051
FAX: (703) 993-2524



- N/A Location of existing and proposed utilities [e.g., water (including wells), sewer (including septic systems), gas, electric, tele communications, cable TV, etc.] and drainage and other easements
- N/A Preliminary estimates of unified stormwater sizing criteria requirements
- N/A Preliminary identification and calculation of stormwater site design credits, if any apply
- N/A Preliminary selection and location of stormwater control measures
- N/A Location of existing and proposed conveyance systems, such as storm drains, inlets, catch basins, channels, swales, and areas of overland flow
- N/A Flow paths
- N/A Location of floodplain/floodway limits and relationship of site to upstream and downstream properties and drainages
- N/A Preliminary location of all contributing drainage areas and points of stormwater discharge, receiving surface waters or karst features into which stormwater discharges, the pre-development and post-development conditions for drainage areas, and the potential impacts of site stormwater on adjoining parcels
- N/A Note all critical areas on the plan, such as critical slopes.

5. Hydrologic and hydraulic analysis, including the following:

- N/A A hydrologic analysis for the existing (pre-development) conditions, including runoff rates, volumes, and velocities, showing the methodologies used and supporting calculations
- N/A A hydrologic analysis for the proposed (post-development) conditions, including runoff rates, volumes, and velocities, showing the methodologies used and supporting calculations
- N/A Hydrologic and hydraulic analysis of the stormwater management system for all applicable design storms
- N/A Preliminary sizing calculations for stormwater control measures, including contributing drainage areas, storage, and outlet configurations
- N/A Preliminary analysis of the potential downstream impacts/effects of the project, where necessary

6. N/A Preliminary erosion and sediment control plan that, at a minimum, meets the requirements outlined in the Virginia Erosion and Sediment Control Regulations and Handbook

7. N/A Preliminary landscaping plans for stormwater control measures and any site reforestation or revegetation

8. N/A Preliminary identification of waiver/exception requests

9. Additional Comments:

Reviewed by:

Date:

Reply To:
Facilities Construction Office
4400 University Dr. Fairfax, VA 22030
PHONE: (703) 993-4051
FAX: (703) 993-2524



**CHECKLIST FOR A FINAL STORMWATER MANAGEMENT SITE PLAN
PREPARATION AND REVIEW**

1. Applicant Information

Final Plan Submission Date _____
Project Name _____
Site Plan/Permit Number _____
Site Address _____
Applicant _____ Phone Number _____
Applicant Legal Address _____
Owner _____ Phone Number _____
Principal Designer _____ Phone Number _____
General Contractor _____ Phone Number _____

2. _____ Signature and stamp of licensed professional consultant and owner certification

3. Plan Status

_____ Approved
_____ Not Approved

Legend: X - Complete
 Inc. - Incomplete/Incorrect
 N/A - Not Applicable

4. _____ Common address and legal description of the site, including the tax reference number(s) and parcel number(s) of the property or properties affected.

5. N/A A narrative that includes a description of current site conditions and proposed development and final site conditions, including proposed use of environmental site design techniques and practices, stormwater control measures, relevant information pertaining to long-term maintenance of these measures (see item #12 below), and a construction schedule.

6. Existing and proposed mapping and plans (recommended scale of 1" = 50', or greater detail), which illustrates the following at a minimum:

- N/A North arrow
- N/A Legend
- N/A Vicinity map
- N/A Existing and proposed topography (minimum of 2-foot contours recommended)
- N/A Property lines
- N/A Perennial and intermittent streams
- N/A Mapping of predominant soils from USDA soils surveys as well as the location of any site-specific test bore hole investigations that may have been conducted and

Reply To:
Facilities Construction Office
4400 University Dr. Fairfax, VA 22030
PHONE: (703) 993-4051
FAX: (703) 993-2524



	information identifying the hydrologic characteristics and structural properties of soils used in the installation of stormwater management facilities
<u>N/A</u>	Boundaries of existing predominant vegetation and proposed limits of clearing and grading
<u>N/A</u>	Location and boundaries of natural feature protection and conservation areas (e.g., wetlands, lakes, ponds, aquifers, public drinking water supplies, etc.) and applicable setbacks (e.g., stream buffers, drinking water well setbacks, septic drainfield setbacks, building setbacks, etc.)
<u>N/A</u>	Identification of any on-site or adjacent water bodies included on the Virginia 303(d) list of impaired waters
<u>N/A</u>	Current land use and location of existing and proposed roads, buildings, parking lots and other impervious areas
<u>N/A</u>	Location and description of any planned demolition of existing structures, roads, etc.
<u>N/A</u>	Proposed land use(s) with a tabulation of the percentage of surface area to be adapted to various uses, including but not limited to planned locations of utilities, roads, parking lots, stormwater management facilities, and easements
<u>N/A</u>	Location of existing and proposed utilities [e.g., water (including wells), sewer (including septic systems), gas, electric, telecommunications, cable TV, etc.] and easements
<u>N/A</u>	Earthwork specifications
<u>N/A</u>	Selection, location and design of both structural and non-structural stormwater control measures, including maintenance access and limits of disturbance
<u>N/A</u>	Storm drainage plans for site areas <i>not</i> draining to any BMP(s)
<u>N/A</u>	Location of existing and proposed conveyance systems, such as storm drains, inlets, catch basins, channels, swales, and areas of overland flow, including grades, dimensions, and direction of flow
<u>N/A</u>	Final drainage patterns and flow paths
<u>N/A</u>	Location of floodplain/floodway limits and relationship of site to upstream and downstream properties and drainage systems
<u>N/A</u>	Location of all contributing drainage areas and points of stormwater discharge, receiving surface waters or karst features into which stormwater discharges, the pre-development and post-development conditions for drainage areas, and the potential impacts of site stormwater on adjoining parcels
<u>N/A</u>	Location and dimensions of proposed channel modifications, such as bridge or culvert crossings
<u>N/A</u>	Final stabilization and landscaping plans

7. Hydrologic and hydraulic analysis, including the following:

<u>N/A</u>	Site map with locations of design points and drainage areas (size in acres) for runoff calculations
<u>N/A</u>	Identification and calculation of stormwater site design credits, if any apply
<u>N/A</u>	Estimates of unified stormwater sizing criteria requirements
<u>N/A</u>	Time of concentration (and associated flow paths)
<u>N/A</u>	Imperviousness of the entire site and each drainage area
<u>N/A</u>	NRCS runoff curve numbers or volumetric runoff coefficients
<u>N/A</u>	A hydrologic analysis for the existing (pre-development) conditions, including runoff rates, volumes, and velocities, showing the methodologies used and supporting calculations

Reply To:
Facilities Construction Office
4400 University Dr. Fairfax, VA 22030
PHONE: (703) 993-4051
FAX: (703) 993-2524



- N/A A hydrologic analysis for the proposed (post-development) conditions, including runoff rates, volumes, and velocities, showing the methodologies used and supporting calculations
- N/A Hydrologic and hydraulic analysis of the stormwater management system for all applicable design storms
- N/A Pollution load and load reduction requirements and calculations
- N/A Final good engineering and sizing calculations for stormwater control measures, including contributing drainage areas, storage, and outlet configurations, verifying compliance with the water quality and water quantity requirements of the regulations
- N/A Stage-discharge or outlet rating curves and inflow and outflow hydrographs for storage facilities
- N/A Final analysis of the potential downstream impacts/effects of the project, where necessary
- N/A Downstream analysis, where detention is proposed
- N/A Dam safety and breach analysis, where necessary

8. Representative cross-section and profile drawings and details of stormwater control measures and conveyances which include the following:

- N/A Existing and proposed structural elevations (e.g., inverts of pipes, manholes, etc.)
- N/A Design water surface elevations
- N/A Structural details of BMP designs, outlet structures, embankments, spillways, grade control structures, conveyance channels, etc.

9. N/A Applicable construction and material specifications, including references to applicable material and construction standards (ASTM, etc.)

10. N/A Erosion and sediment control plan that, at a minimum, meets the requirements outlined in the Virginia Erosion and Sediment Control Regulations and Handbook

11. N/A Landscaping plans for stormwater control measures and any site reforestation or revegetation

12. Operations and maintenance plan/agreement that includes the following:

- N/A Name, legal address and phone number of the party or parties responsible for long-term maintenance activities
- N/A Description and schedule of maintenance tasks
- N/A Identification/description of the source of funding to support maintenance activities
- N/A Description of access and safety issues
- N/A Procedures for testing and disposal of sediments, if required
- N/A Right-of-entry authorization for local government inspections/repairs, as needed

13. N/A Evidence of acquisition of all applicable local and non-local permits

14. N/A Waiver/exception requests

Reply To:
Facilities Construction Office
4400 University Dr. Fairfax, VA 22030
PHONE: (703) 993-4051
FAX: (703) 993-2524



15. N/A Evidence of acquisition of all necessary legal agreements (e.g., easements, covenants, land trusts, etc.)
16. N/A Applicable supporting documents and studies (e.g., infiltration tests, geotechnical investigations, TMDLs, flood studies, etc.)
17. N/A Other required permits
18. Additional Comments

Reviewed by:

Date:

APPENDIX E:

Environmental Compliance

Report

Reply To:
Facilities Construction Office
4400 University Dr.
Fairfax, VA 22030
PHONE: (703) 993-4051 FAX: (703) 993-2624



Environmental Compliance Report

Project Name: _____	Project Location: _____
Project Authority: _____	Permit No.: _____
Project Operator: _____	Insp. Date/Time: _____
Inspector: _____	Weather/Rain Info: _____
Permit Displayed: Mason LD Permit <input type="checkbox"/> VSMP <input type="checkbox"/> Sub Sur Verification Permit <input type="checkbox"/>	

STAGE OF CONSTRUCTION

Pre-Cons. Conference <input type="checkbox"/>	Building Construction <input type="checkbox"/>	Construction SWM Facilities <input type="checkbox"/>
Clearing & Grubbing <input type="checkbox"/>	Finish Grading <input type="checkbox"/>	Maintenance of SWM Facilities <input type="checkbox"/>
Rough Grading <input type="checkbox"/>	Final Stabilization <input type="checkbox"/>	Construction of Site Utilities <input type="checkbox"/>

State/Local Regulation ⁽¹⁾ (citation)	Occurrence		Practice/Problem/Location of Condition Observed and Description ⁽²⁾	Corrective Action Required, Completed, and/or Recommendations/Comments	Reference Image
	Initial	Repeat			

Additional Comments: Additional images may be provided to help determine location of violation. If further explanation is needed, or if you have any questions or concerns, please contact the Mason LD Inspector.

(1) Refers to applicable regulation found in the most recent publication of the Virginia Erosion and Sediment Control Regulations (9VAC25-840), Virginia Stormwater Management Regulations (9VAC25-870), or local ESC/SWM ordinance
 (2) Note whether or not off-site damage resulting from the practice, problem, or violation was evident during the inspection.

REQUIRED CORRECTIVE ACTION DEADLINE DATE: _____ Re-inspection +/-: _____

The required corrective action deadline date applies to all observations noted on this report. If listed observation(s) currently constitute non-compliance and/or required corrective actions are not completed by the deadline date, a **NOTICE TO COMPLY, STOP WORK ORDER**, and/or other enforcement actions may be issued to the entity responsible for ensuring compliance on the above project.

Inspector: _____ Signature _____ Date _____

Hand deliver, fax, or email written notification to all appropriate parties within 24 hours of inspection date.			
Report Recipient: _____			
Name	Email or Address	Date	
Copy 1-Onsite Project Representative	Copy 2-Project Authority	Copy 3-DEQ Project File	

APPENDIX F:

Notice of Termination



- Land Disturbance
- Erosion and Sediment Control
- Stormwater Management

Land Disturbance Permit Notice of Termination

Permit #: Project Name: Campus:

Contractor:

Address:

Contact: Contact #:

Responsible Land Disturber: Certificate #:

Termination Recommended By: Date:

Reasons For Terminating:

- Necessary permanent control measures included in the SWPPP for the site are in place and functioning effectively and final stabilization has been achieved on all portions of the site for which the operator is responsible;
- Another operator has assumed control over all areas of the site that have not been finally stabilized and obtained coverage for the ongoing discharge; or
- Coverage under an alternative VPDES permit or state permit has been obtained.

Permit Termination Checklist (if applicable):

- Verify permanent stabilization
- Inspect permanent BMP/LIDs (Functional)
- Confirm positive drainage
- The Virginia Construction General Permit is closed
- The county and/or city in the surrounding area has received final payment on any fees and has received final utility as-built drawings.

Contractor Certification Statement:

"I certify that to the best of my knowledge that the referenced project is constructed according to the approved plans and accepted industry standards. I guarantee the performance of said construction, under reasonable circumstances, for one-year after the signed date. This includes but not limited to installed vegetation, hardscape, and structural practices. In the event of failure the Contractor is responsible for replacement and/or repair and the performance warranty period will start over after Owner acceptance. If the Owner modifies the installed, this performance guarantee is null and void."

Print Name: _____ Title: _____

Signature: _____ Date: _____

Terminated By: Date:

APPENDIX G:

Variance Request Form

Reply To:
Facilities Construction Office
4400 University Dr.
Fairfax, VA 22030
PHONE: (703) 993-4051
FAX: (703) 993-2524



Variance Request Form

Requested By: _____ Date: _____
Street Address: _____
City/Town/Zip: _____
Telephone #: _____ Fax #: _____
Email Address: _____
Project Name: _____ Campus: _____
Project Number: _____

Project Description: (include existing conditions, and adjacent area, soil characterization, critical and sensitive areas, etc.)

--

Variance Requested for: (include appropriate minimum standards and requirements):

--

Reasons and Justification for Variance Request: (include mitigation, ESC measures, permanent stabilization, maintenance, etc.)

--

Signature of Applicant: _____ Date: _____

APPENDIX H:

ESC Control Structures

The use of Virginia Erosion and Sediment Control Handbook (VESCH), along with accompanying technical documents and guidance, control measures is strongly preferred. Non-VESCH control measures, best management practices (BMP), and specifications are included in the Annual Standards and Specifications, and their use may be further reviewed and approved by the applicable DEQ Regional Office on a project-specific basis, if necessary.

For all non-VESCH and proprietary control measures, included are applicable practical information including definition, purpose, conditions where practice applies, planning considerations, design criteria, construction specifications, design tables and plates, and maintenance and inspections. Non-VESCH and proprietary control measures shall be installed per the manufacturer's instructions and with the intent of the VESCH specifications. Should non-VESCH control measures fail to effectively control soil erosion, sediment deposition, and non-agricultural runoff, then VESCH control measures shall be utilized.

APPENDIX H.1

SILTSACK® Specification Control of Sediment Entering Catch Basins or equal substitute

1.0 Description

1.1 This work shall consist of furnishing, installing, maintaining, and removing Siltsack® sediment control device as directed by the engineer or as shown on the contract drawings. Siltsack sediment control device is manufactured by:

ACF Environmental, Inc. 2831
Cardwell Drive Richmond,
Virginia 23234 Phone: 800-448-
3636 Fax: 804-743-7779
www.acfenvironmental.com

2.0 Materials

2.1 Siltsack®

2.1.1 Siltsack shall be manufactured from a specially designed woven polypropylene geotextile manufactured by SI® Geosolutions and sewn by a double needle machine, using a high strength nylon thread.

SI Geosolutions:
www.sigeosolutions.com (800) 621-0444

2.1.2 Siltsack will be manufactured to fit the opening of the catch basin or drop inlet. Siltsack will have the following features: two dump straps attached at the bottom to facilitate the emptying of Siltsack; Siltsack shall have lifting loops as an integral part of the system to be used to lift Siltsack from the basin; Siltsack shall have a restraint cord approximately halfway up the sack to keep the sides away from the catch basin walls, this yellow cord is also a visual means of indicating when the sack should be emptied. Once the strap is covered with sediment, Siltsack should be emptied, cleaned, and placed back into the basin.

2.1.3 Siltsack seams shall have a certified average wide width strength per ASTM D-4884 standards as follows:

<u>SILTSACK Style</u>	<u>Test Method</u>	<u>Test Method</u>
Regular Flow	ASTM D-4884	165.0 lbs./in

SILTSACK Regular Flow

<u>Property</u>	<u>Test Method</u>	<u>Units</u>	<u>Test Results</u>
Grab Tensile	ASTM D-4632	lbs.	315x300
Grab Elongation	ASTM D-4632	%	15x15
Puncture	ASTM D-4833	lbs	.125
Mullen Burst	ASTM D-3786	P.S.I.	650

<u>Property</u>	<u>Test Method</u>	<u>Units</u>	<u>Test Results</u>
Trapezoid Tear	ASTM D-4533	lbs.	120x150
UV Resistance	ASTM D-4355	%	90
Apparent Opening	ASTM D-4751	US Sieve	40
Flow Rate	ASTM D-4491	Gal/Min/Ft ²	40
Permittivity	ASTM D-4491	sec-1	0.55

All properties are Minimum Average Roll Values (MARV)

3.0 Construction Sequence

3.1 General

3.1.1 To install Siltsack in the catch basin, remove the grate and place the sack in the opening. Hold out approximately six inches of the sack outside the frame. This is the area of the lifting straps. Replace the grate to hold the sack in place.

3.1.2 When the restraint cord is no longer visible, Siltsack is full and should be emptied.

3.1.3 To remove Siltsack, take two pieces of 1" diameter rebar and place through the lifting loops on each side of the sack to facilitate the lifting of Siltsack.

3.1.4 To empty Siltsack, place it where the contents will be collected. Place the rebar through the lift straps (connected to the bottom of the sack) and lift. This will turn Siltsack inside out and empty the contents. Clean out and rinse. Return Siltsack to its original shape and place back in the basin.

3.1.5 Siltsack is reusable. Once the construction cycle is complete, remove Siltsack from the basin and clean. Siltsack should be stored out of the sunlight until needed on another project.

4.0 Basis of Payment

4.1 Payment for all Siltsack used during the construction is to be included in the bid price for the overall erosion and sediment control plan unless unit price is requested.

* *Siltsack is covered by U.S. Patent No. 5,575,925.*

Available in Texas from:

EcoSupplies
6719 Theall Rd., Suite C
Houston, Texas
281-537-8657 Voice
281-537-1146 Fax
www.ecosupplies.com

INSERT 1" REBAR
FOR BAG REMOVAL
FROM INLET
(REBAR NOT INCLUDED)

OPTIONAL OVERFLOW

SILTSACK®

DUMP LOOPS
(REBAR NOT INCLUDED)

DEPTH = D

WIDTH = W

LENGTH = L

SIDE VIEW INSTALLED

EXPANSION
RESTRAINT

INSTALLATION
DETAIL

DETAIL OF INLET SEDIMENT CONTROL DEVICE TYPE A – WITHOUT CURB DEFLECTOR



Environmental
Your Complete Source for
Geosynthetic Solutions

ACF Environmental, Inc.
2831 Cardwell Rd.
Richmond, Virginia 23234
(800) 448-3636

SILTSACK®

SPECIFICATIONS

NOTE: THE SILTSACK® WILL BE MANUFACTURED FROM A WOVEN POLYPROPYLENE FABRIC THAT MEETS OR EXCEEDS THE FOLLOWING SPECIFICATIONS.

REGULAR FLOW SILTSACK®

(FOR AREAS OF LOW TO MODERATE PRECIPITATION AND RUN-OFF)

PROPERTIES	TEST METHOD	UNITS
GRAB TENSILE STRENGTH	ASTM D-4632	300 LBS
GRAB TENSILE ELONGATION	ASTM D-4632	20 %
PUNCTURE	ASTM D-4833	120 LBS
MULLEN BURST	ASTM D-3786	800 PSI
TRAPEZOID TEAR	ASTM D-4533	120 LBS
UV RESISTANCE	ASTM D-4355	80 %
APPARENT OPENING SIZE	ASTM D-4751	40 US SIEVE
FLOW RATE	ASTM D-4491	40 GAL/MIN/SQ FT
PERMITTIVITY	ASTM D-4491	0.55 SEC -1

HI-FLOW SILTSACK®

(FOR AREAS OF MODERATE TO HEAVY PRECIPITATION AND RUN-OFF)

PROPERTIES	TEST METHOD	UNITS
GRAB TENSILE STRENGTH	ASTM D-4632	265 LBS
GRAB TENSILE ELONGATION	ASTM D-4632	20 %
PUNCTURE	ASTM D-4833	135 LBS
MULLEN BURST	ASTM D-3786	420 PSI
TRAPEZOID TEAR	ASTM D-4533	45 LBS
UV RESISTANCE	ASTM D-4355	90 %
APPARENT OPENING SIZE	ASTM D-4751	20 US SIEVE
FLOW RATE	ASTM D-4491	200 GAL/MIN/SQ FT
PERMITTIVITY	ASTM D-4491	1.5 SEC -1

OIL-ABSORBANT SILTSACK®

(FOR AREAS WHERE THERE IS A CONCERN FOR OIL RUN-OFF OR SPILLS)

DEPENDING ON YOUR PARTICULAR APPLICATION, THE SILTSACK CAN BE MADE FROM EITHER ONE OF THE ABOVE FABRICS WITH AN OIL-ABSORBANT PILLOW INSERT OR, MADE COMPLETELY FROM AN OIL-ABSORBANT SILTSACK , WITH A WOVEN PILLOW INSERT.

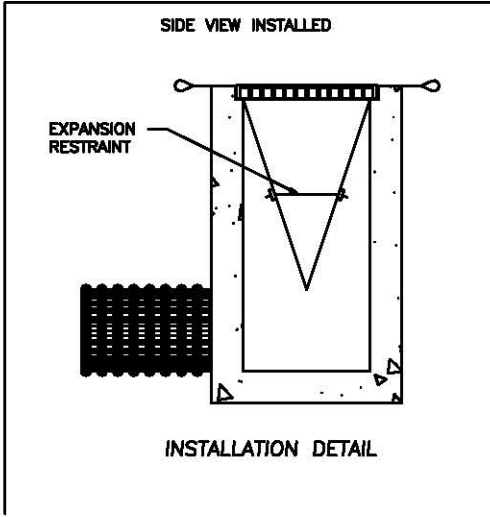
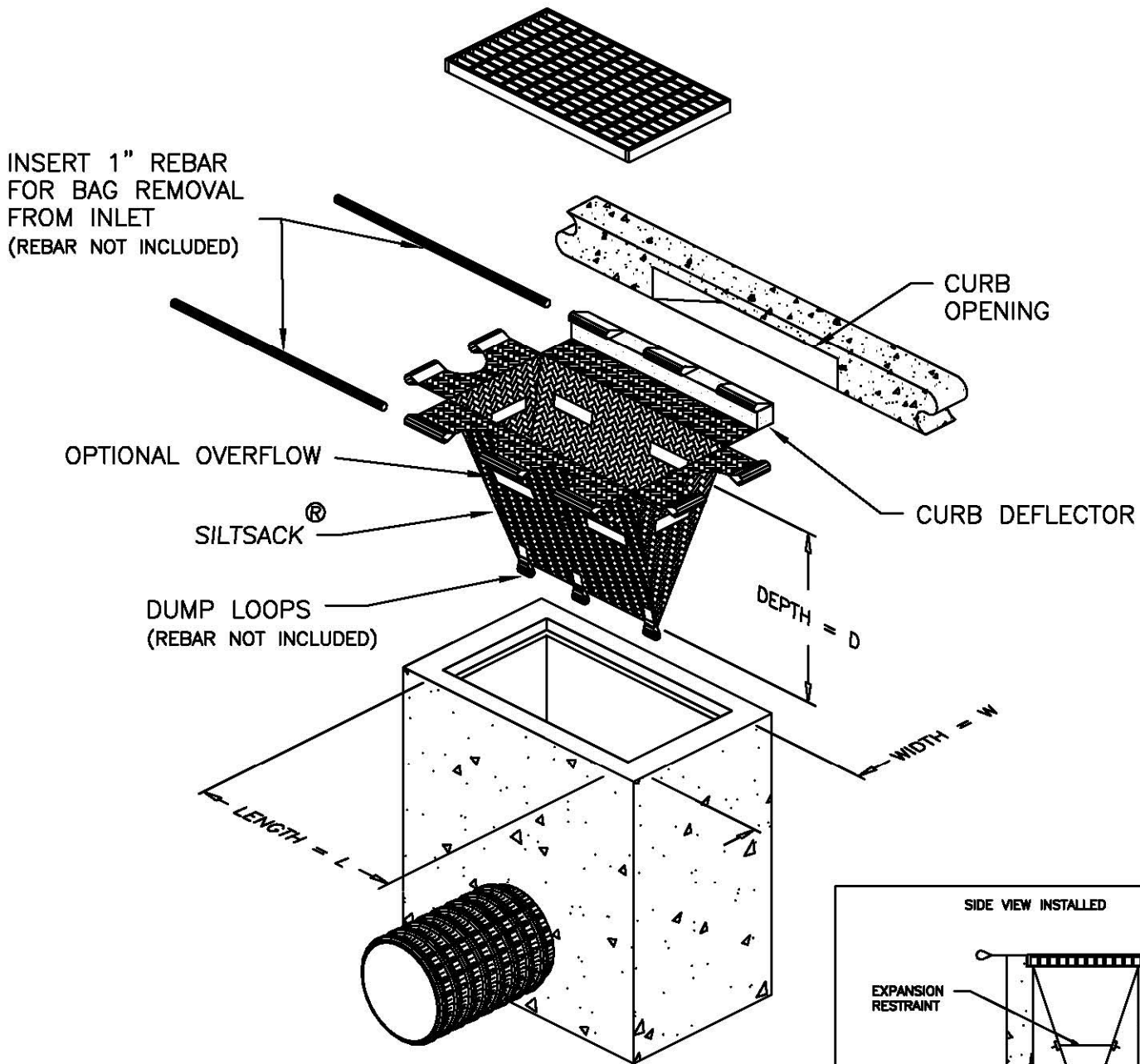

DETAIL OF INLET SEDIMENT CONTROL DEVICE
TYPE B – WITH CURB DEFLECTOR

SILTSACK®

SPECIFICATIONS

NOTE: THE SILTSACK® WILL BE MANUFACTURED FROM A WOVEN POLYPROPYLENE FABRIC THAT MEETS OR EXCEEDS THE FOLLOWING SPECIFICATIONS.

REGULAR FLOW SILTSACK®

(FOR AREAS OF LOW TO MODERATE PRECIPITATION AND RUN-OFF)

PROPERTIES	TEST METHOD	UNITS
GRAB TENSILE STRENGTH	ASTM D-4632	300 LBS
GRAB TENSILE ELONGATION	ASTM D-4632	20 %
PUNCTURE	ASTM D-4833	120 LBS
MULLEN BURST	ASTM D-3786	800 PSI
TRAPEZOID TEAR	ASTM D-4533	120 LBS
UV RESISTANCE	ASTM D-4355	80 %
APPARENT OPENING SIZE	ASTM D-4751	40 US SIEVE
FLOW RATE	ASTM D-4491	40 GAL/MIN/SQ FT
PERMITTIVITY	ASTM D-4491	0.55 SEC -1

HI-FLOW SILTSACK®

(FOR AREAS OF MODERATE TO HEAVY PRECIPITATION AND RUN-OFF)

PROPERTIES	TEST METHOD	UNITS
GRAB TENSILE STRENGTH	ASTM D-4632	265 LBS
GRAB TENSILE ELONGATION	ASTM D-4632	20 %
PUNCTURE	ASTM D-4833	135 LBS
MULLEN BURST	ASTM D-3786	420 PSI
TRAPEZOID TEAR	ASTM D-4533	45 LBS
UV RESISTANCE	ASTM D-4355	90 %
APPARENT OPENING SIZE	ASTM D-4751	20 US SIEVE
FLOW RATE	ASTM D-4491	200 GAL/MIN/SQ FT
PERMITTIVITY	ASTM D-4491	1.5 SEC -1

OIL-ABSORBANT SILTSACK®

(FOR AREAS WHERE THERE IS A CONCERN FOR OIL RUN-OFF OR SPILLS)

DEPENDING ON YOUR PARTICULAR APPLICATION, THE SILTSACK CAN BE MADE FROM EITHER ONE OF THE ABOVE FABRICS WITH AN OIL-ABSORBANT PILLOW INSERT OR, MADE COMPLETELY FROM AN OIL-ABSORBANT SILTSACK ,® WITH A WOVEN PILLOW INSERT.

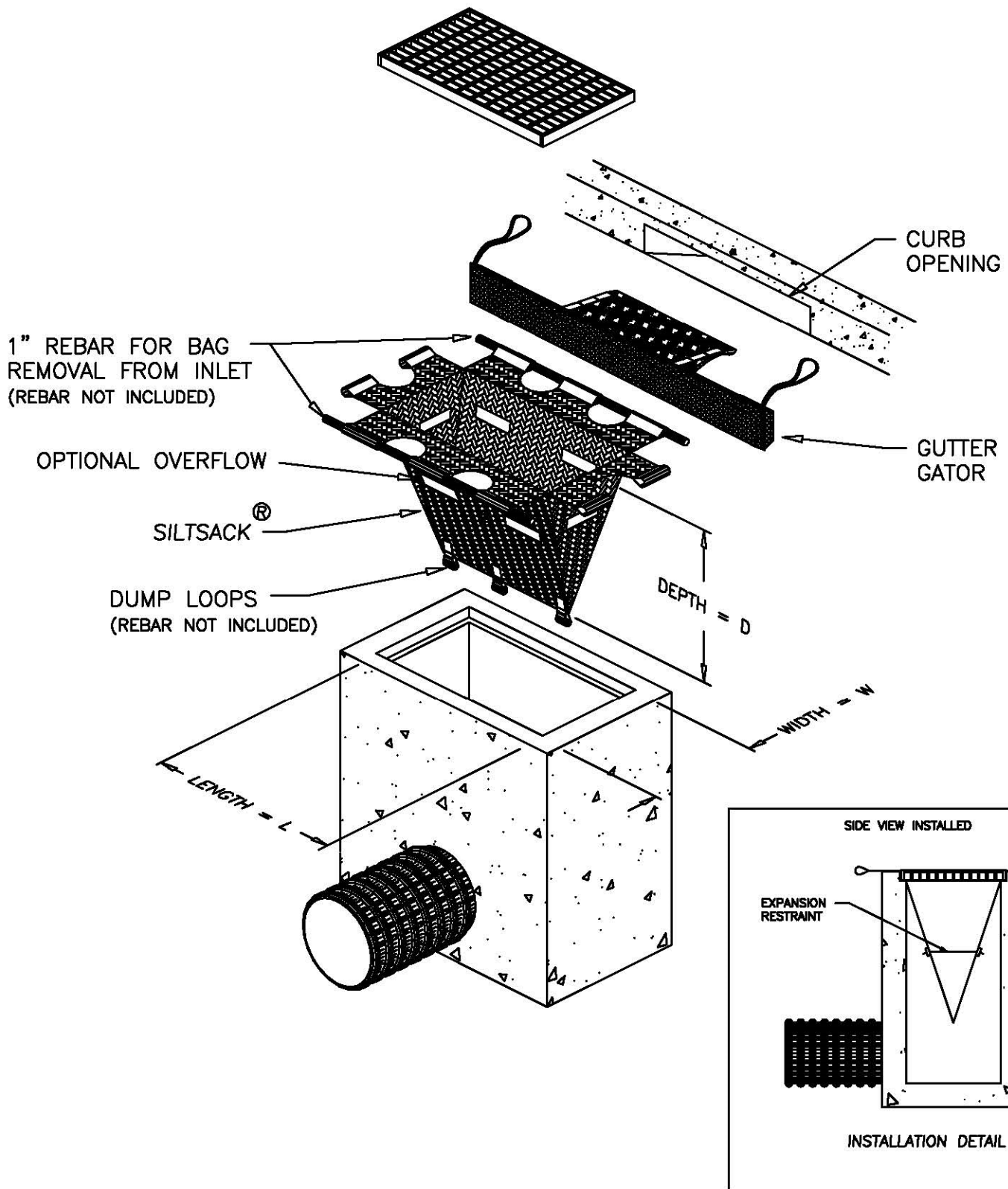

DETAIL OF INLET SEDIMENT CONTROL DEVICE
WITH GUTTER GATOR

SILTSACK® GUTTER GATOR® COMBINATION
SPECIFICATIONS

NOTE: THE SILTSACK® WILL BE MANUFACTURED FROM A WOVEN POLYPROPYLENE FABRIC THAT MEETS OR EXCEEDS THE FOLLOWING SPECIFICATIONS.

REGULAR FLOW SILTSACK®

(FOR AREAS OF LOW TO MODERATE PRECIPITATION AND RUN-OFF)

PROPERTIES	TEST METHOD	UNITS
GRAB TENSILE STRENGTH	ASTM D-4632	300 LBS
GRAB TENSILE ELONGATION	ASTM D-4632	20 %
PUNCTURE	ASTM D-4833	120 LBS
MULLEN BURST	ASTM D-3786	800 PSI
TRAPEZOID TEAR	ASTM D-4533	120 LBS
UV RESISTANCE	ASTM D-4355	80 %
APPARENT OPENING SIZE	ASTM D-4751	40 US SIEVE
FLOW RATE	ASTM D-4491	40 GAL/MIN/SQ FT
PERMITTIVITY	ASTM D-4491	0.55 SEC -1

HI-FLOW SILTSACK®

(FOR AREAS OF MODERATE TO HEAVY PRECIPITATION AND RUN-OFF)

PROPERTIES	TEST METHOD	UNITS
GRAB TENSILE STRENGTH	ASTM D-4632	265 LBS
GRAB TENSILE ELONGATION	ASTM D-4632	20 %
PUNCTURE	ASTM D-4833	135 LBS
MULLEN BURST	ASTM D-3786	420 PSI
TRAPEZOID TEAR	ASTM D-4533	45 LBS
UV RESISTANCE	ASTM D-4355	90 %
APPARENT OPENING SIZE	ASTM D-4751	20 US SIEVE
FLOW RATE	ASTM D-4491	200 GAL/MIN/SQ FT
PERMITTIVITY	ASTM D-4491	1.5 SEC -1

OIL-ABSORBANT SILTSACK®

(FOR AREAS WHERE THERE IS A CONCERN FOR OIL RUN-OFF OR SPILLS)

DEPENDING ON YOUR PARTICULAR APPLICATION, THE SILTSACK CAN BE MADE FROM EITHER ONE OF THE ABOVE FABRICS WITH AN OIL-ABSORBANT PILLOW INSERT OR, MADE COMPLETELY FROM AN OIL-ABSORBANT SILTSACK WITH A WOVEN PILLOW INSERT.

APPENDIX H.2

GUTTERBUDDY® Specification For Curb Gutter Storm Drains or equal substitute

1.0 Description

1.1 This work shall consist of furnishing, placing, maintaining and removing the Gutterbuddy® sediment control device as directed by the engineer and as shown on the contract drawings. The Gutterbuddy® sediment control system distributed nationally by:

ACF Environmental, Inc.
2831 Cardwell Drive
Richmond, Virginia 23234
Phone: 800-448-3636 Fax: 804-743-7779
www.acfenvironmental.com

2.0 Materials

2.1 GUTTERBUDDY®

The Gutterbuddy® shall be a synthetic filter manufactured from recycled synthetic fibers.

2.1.1 The Gutterbuddy® will be manufactured to be 9" in diameter and are available in 4', 6', 8', 10', 12', 14' and 16' lengths and are to be sized a minimum of twenty four (24) inches longer than the curb inlet opening. This will allow for sufficient length to cover the inlet with twelve (12) inches beyond the inlet on both ends.

3.0 Construction Sequence

3.1 General

- 3.1.1 Install the Gutterbuddy® in front of the curb inlet opening. Each end of the Gutterbuddy® should overlap the curb inlet approximately 12".
- 3.1.2 When installed, the overflow bypass holes drilled through the Gutterbuddy® should be oriented to be parallel with the surface of the pavement. This will minimize ponding.
- 3.1.3 The Gutterbuddy® should be cleaned if a visual inspection shows silt and debris buildup around the Gutterbuddy®.
- 3.1.4 To remove the Gutterbuddy®, lift out of the opening.

3.1.5 The Gutterbuddy® is reusable. Once the construction project is complete and it is no longer needed for sediment control, remove, clean and store out of the sunlight until needed on the next project.

3.1.6 Ponding is likely if sediment is not removed regularly, or if the overflow bypass holes are not oriented properly. Inspection of Gutterbuddy® should be on a regular basis and immediately after major rain events.

4.0 Basis of Payment

4.1 The payment for any Gutterbuddy® used during the construction is to be included in the bid of the overall erosion and sediment control plan and priced by the linear foot, or per unit based on length.

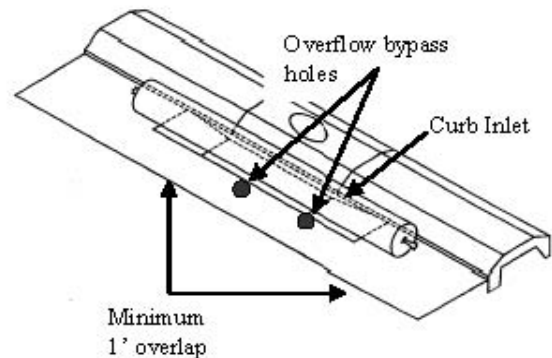

Available in Texas from:

EcoSupplies
6719 Theall Rd., Suite C
Houston, TX 77066
281-537-8657 Voice
281-537-1146 Fax
www.ecosupplies.com

APPENDIX H.3

SedCatch® Dewatering Bag/Tube™ SPECIFICATION or equal substitute

1.0 Description:

1.1 Work covered under this item consists of furnishing, installing, maintaining, and removal of the SedCatch Dewatering Bag/Tube. The purpose is to collect sediment that is contained in the water that is being pumped, to prevent scour and erosion from water exiting a pipe at high velocity, to defuse the water over a wider area to minimize erosion as the water drains away, and to retain oil contained within effluent.

2.0 Material:

- 2.1 The above geotextile seams shall be double stitched with a high strength thread.
- 2.2 The SedCatch Dewatering Bag/Tube shall be made of a nonwoven, needle punched geotextile with the following characteristics:

Material	Polypropylene
Weight	8 oz
Construction	Needle Punched

<u>Property</u>	<u>Test Method</u>	<u>MARV</u>
Tensile Strength (Grab)	ASTM D4632	225 lbs
Elongation	ASTM D4632	50%
Puncture	ASTM D4833	130 lbs
Mullen Burst	ASTM D3786	425 psi
Trapezoidal Tear	ASTM D4533	90 lbs
UV Resistance	ASTM D4355	70%
Apparent Opening Size	ASTM D4751	80 Sieve = .18mm
Permittivity	ASTM D4491	1.26 sec ⁻¹
Water Flow Rate	ASTM D4491	100 gpm/ft ²

3.0 Installation and Use:

- 3.1 Place SedCatch Dewatering Bag/Tube on the ground or on a trailer over a relatively level, stabilized area.
- 3.2 Insert discharge hose a minimum of 5 ft inside SedCatch Dewatering Bag/Tube and secure with a rope (included wrapped 6 times around the snout over a 6 inch width of the

bag.

- 3.3 Insert discharge pipe a minimum of 5 ft inside SedCatch Dewatering Bag/Tube and secure with a rope wrapped 6 times around the snout over a 6 inch width of the bag. To close the open end of the tube; overlap the tube 2 ft from the end, gather the center of the doubled up portion forming a bow tie, secure with a rope wrapped multiple times.

4.0 Maintenance:

- 4.1 Replace SedCatch Dewatering Bag when half full of sediment or when the sediment has reduced the flow rate of the pump discharge to an impractical rate,
OR; Empty SedCatch Sediment Tube when half full of sediment or when the sediment has reduced the flow rate of the pump discharge to an impractical rate,
OR; As directed by engineer or inspector.

5.0 Method of Measurement:

- 5.1 The quantity to be paid for the actual number of SedCatch Dewatering Bags/Tubes that are actually used.

6.0 Basis of Payment:

- 6.1 The unit price shall include labor, equipment, and materials necessary to install, maintain, and dispose of SedCatch Dewatering Bags/Tubes

- 6.2 Payment for completed work will be made at the contract price for:

UNITS	DESCRIPTION	EA
Quan	Size of Bag/Tube	Unit price

SedCatch® Dewatering Bag/Tube™
as manufactured by: www.SedCatch.com
392 Congress Park Dr.,
Dayton, OH 45459
937-435-5075 Voice

Dewatering Bag Standard Drawing

The purpose of a Dewatering Bag is to collect sediment contained in the discharged water, to prevent the scour and erosion from water exiting a pipe at high velocity, to defuse the water over a wider area to minimize erosion as the water drains away, and to retain oil contained within effluent.

A SedCatch® dewatering bag or approved equal should be used anytime water is pumped on the site.

SedCatch® Dewatering Bag

www.SedCatch.com

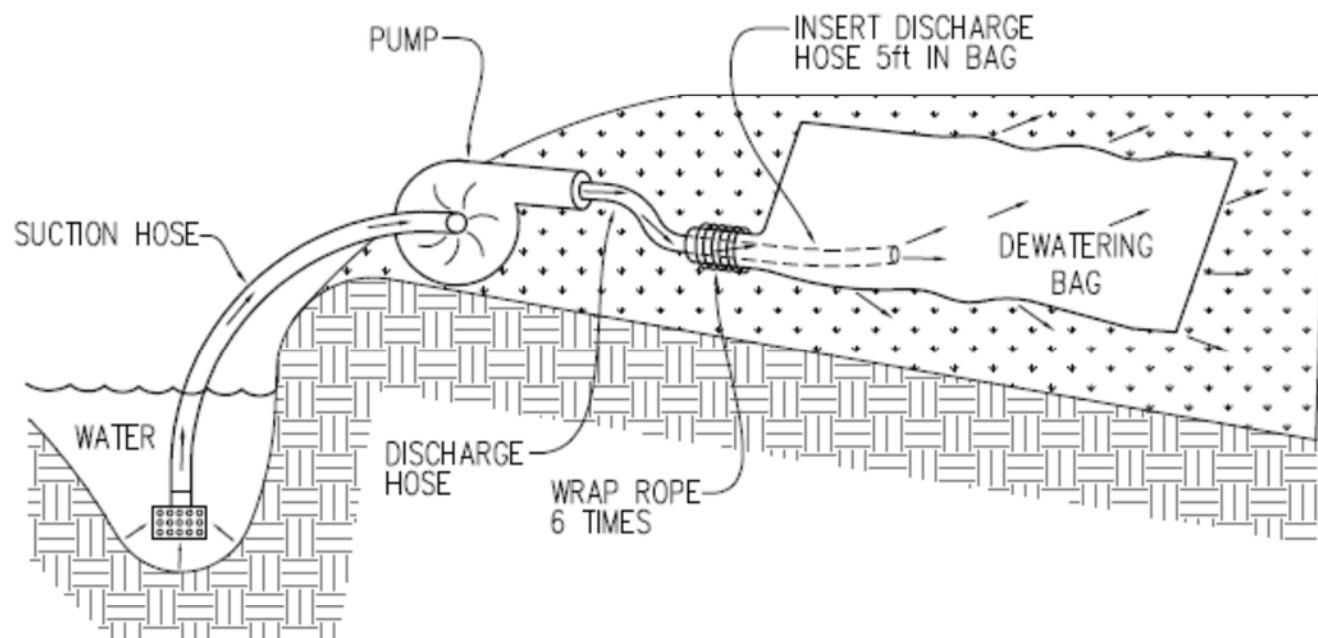

Installation and Use:

1. Place SedCatch® Dewatering Bag on the ground or on a trailer over a relatively level, stabilized area.
2. Insert discharge pipe a minimum of 5ft. inside SedCatch® dewatering bag and secure with a rope (included) wrapped 6 times around the snout over a 6 inch width of the bag.
3. Replace SedCatch® Dewatering Bag when half full of sediment or when the sediment has reduced the flow rate of the pump discharge to an impractical amount.

Maintenance and Disposal:

1. Remove and dispose of accumulated sediment away from waterways or environmentally sensitive areas. Slit open Sediment Bag and remove accumulated sediment. Dispose of bag at an appropriate recycling or solid waste facility. OR; as directed by engineer or inspector.

Dewatering Bag/Tube™ Standard Drawing

The purpose of a Dewatering Bag/Tube™ is to collect sediment contained in the discharged water, to prevent the scour and erosion from water exiting a pipe at high velocity, to defuse the water over a wider area to minimize erosion as the water drains away, and to retain oil contained within effluent.

A SedCatch® Dewatering Bag/Tube™ or approved equal should be used anytime water is pumped on the site.

SedCatch® Dewatering Bag

www.SedCatch.com

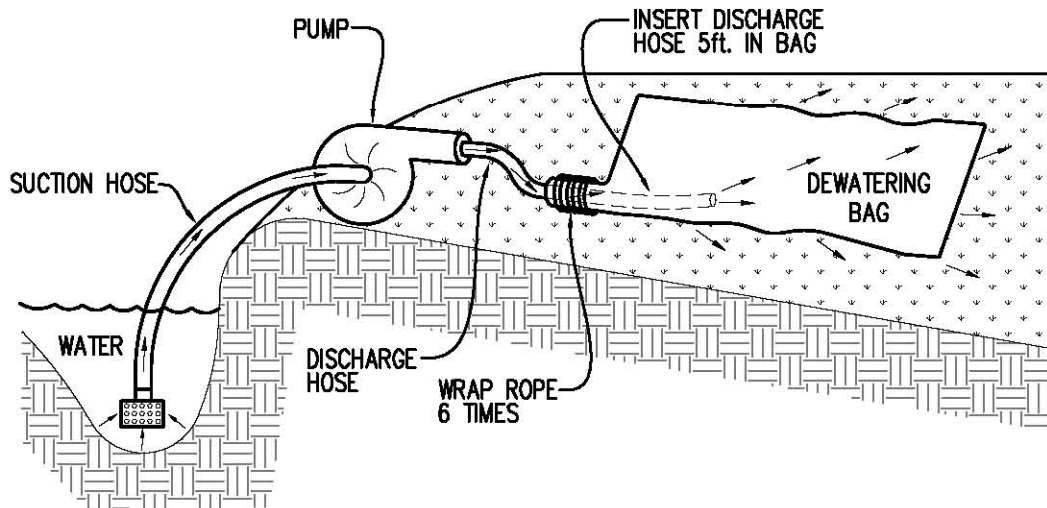

SedCatch® Dewatering Tube™

www.SedCatch.com

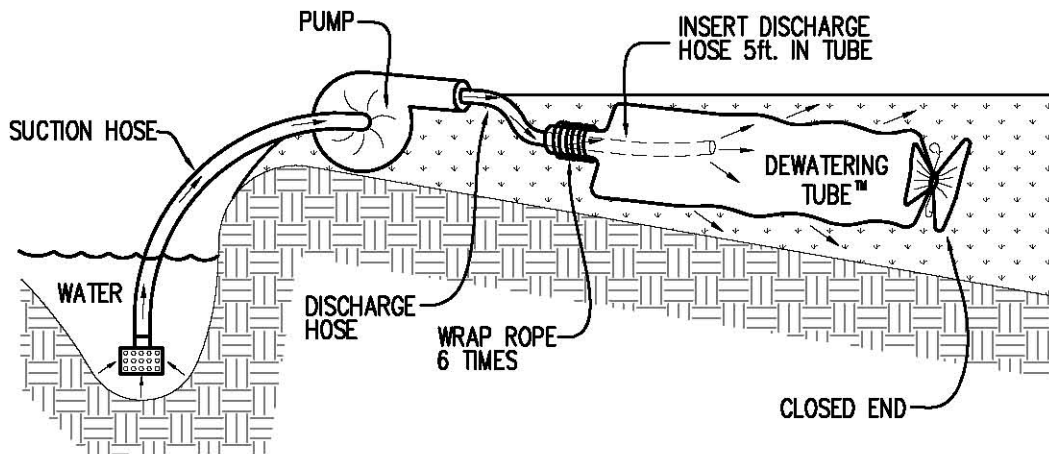

Installation and Use:

1. Place SedCatch® Dewatering Bag/Tube™ on the ground or on a trailer over a relatively level, stabilized area.
2. Insert discharge pipe a minimum of 5ft. inside SedCatch® Dewatering Bag/Tube™ and secure with a rope (included) wrapped 6 times around the snout over a 6 inch width of the bag. To close Open end of the Dewatering Tube™: Overlap the tube 2 ft. from the end. Gather the center of the doubled-up portion forming a bow tie. Secure with a rope wrapped multiple times.
3. Replace SedCatch® Dewatering Bag when half full of sediment or when the sediment has reduced the flow rate of the pump discharge to an impractical amount, OR; empty SedCatch® Sediment Tube™ when half full of sediment or when the sediment has reduced the flow rate of the pump discharge to an impractical rate.

Maintenance and Disposal:

1. Remove and dispose of accumulated sediment away from waterways or environmentally sensitive areas. Slit open Dewatering Bag and remove accumulated sediment. Dispose of bag at an appropriate recycling or solid waste facility, OR: open both ends of the SedCatch® Dewatering Tube™, pick it up in the center and dump accumulated sediment out of both ends. Allow to dry and store for re-use, OR; as directed by engineer or inspector.

Dewatering Tube™ Standard Drawing

The purpose of a Dewatering Tube™ is to collect sediment contained in the discharged water, to prevent the scour and erosion from water exiting a pipe at high velocity, to defuse the water over a wider area to minimize erosion as the water drains away, and to retain oil contained within effluent.

A SedCatch® Dewatering Tube™ or approved equal should be used anytime water is pumped on the site.

SedCatch® Dewatering Tube™

www.SedCatch.com

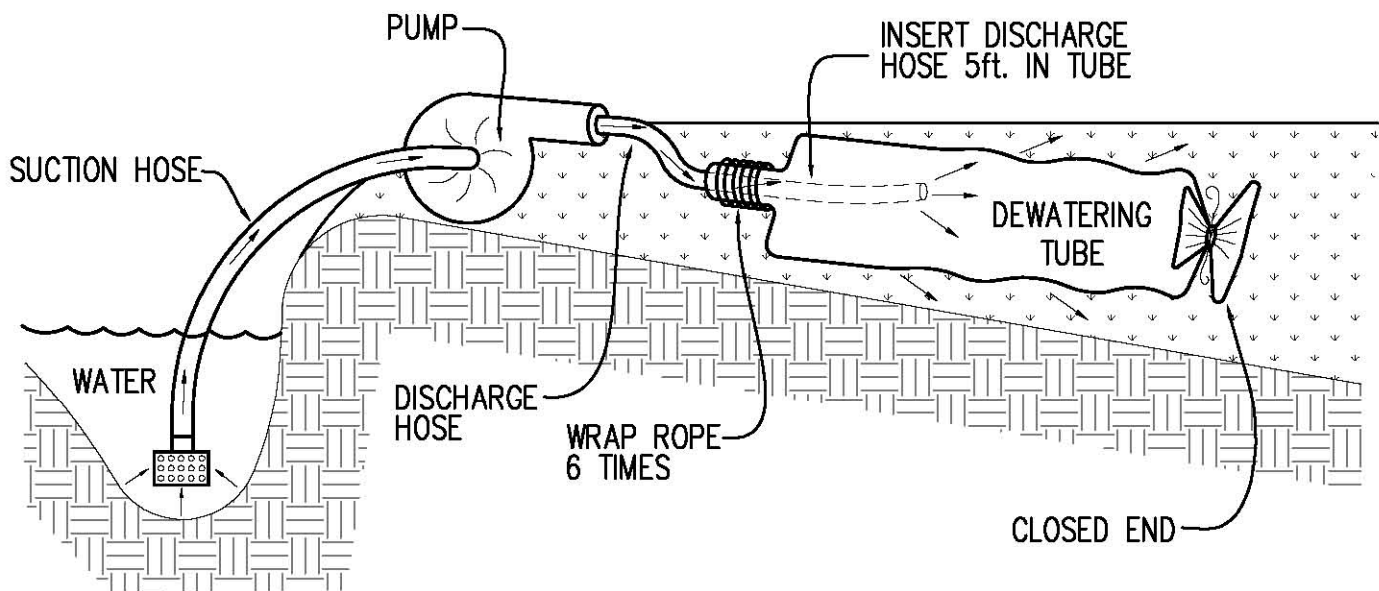

Installation and Use:

1. Place SedCatch® Dewatering Tube™ on the ground or on a trailer over a relatively level, stabilized area.
2. Insert discharge pipe a minimum of 5ft. inside SedCatch® Dewatering Tube™ and secure with a rope (included) wrapped 6 times around the snout over a 6 inch width of the bag. To close and open end of the Dewatering Tube™: Overlap the tube 2 ft. from the end. Gather the center of the doubled-up portion forming a bow tie. Secure with a rope wrapped multiple times.
3. Empty SedCatch® Dewatering Tube™ when half full of sediment or when the sediment has reduced the flow rate of the pump discharge to an impractical amount.

Maintenance and Disposal:

1. Remove and dispose of accumulated sediment away from waterways or environmentally sensitive areas. Open both ends of the SedCatch® Dewatering Tube™, pick it up in the center and dump accumulated sediment out of both ends. Allow to dry and store for re-use OR; as directed by engineer or inspector.

APPENDIX H.4

Filter Fabric Inlet Protection

PLAN

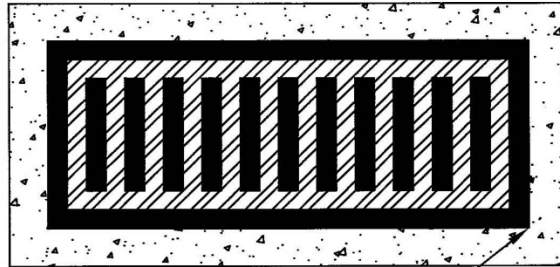

FILTER FABRIC

CROSS SECTION

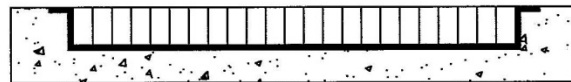

NOTE:

- 1) CLEAN OUT AND CHANGE FABRIC AT A MINIMUM BI-WEEKLY.

NOT TO SCALE

MASON LAND DEVELOPMENT	GEORGE MASON UNIVERSITY	DETAIL NO: LD-003
APPROVED 9-29-2011 DATE		
	FILTER FABRIC INLET PROTECTION	

APPENDIX H.5

Super Silt Fence Specification

FAIRFAX COUNTY PUBLIC FACILITIES MANUAL

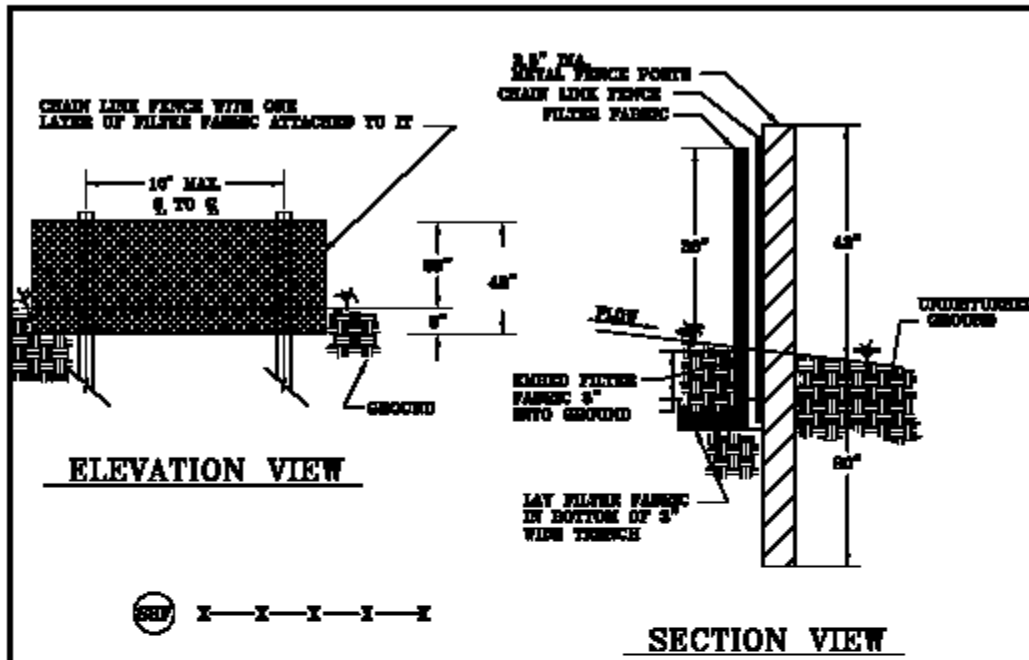

SUPER SILT FENCE
NO SCALE

FENCING

Chain link fence shall be 36" above grade with 12" embedded for a total fabric width of 48". The post shall be 48" above grade with 30" placed below grade (without concrete) for a total length of 78".

NOTES

1. Chain link fence shall be fastened securely to fence posts with wire ties.
2. Filter fabric shall be fastened securely to chain link fence with ties spaced horizontally 24" at the top and mid-section.
3. Physical properties of the filter fabric shall conform to the latest edition of THE VIRGINIA EROSION & SEDIMENT CONTROL HANDBOOK.
4. When two sections of filter fabric adjoin each other, they shall be overlapped by 6".
5. Maintenance shall be performed as needed and material shall be removed when sediment build-up reaches 50% of the height of the super silt fence.

Rev. Sep. 11-0110.3,
11-0110.37

SUPER SILT FENCE
NO SCALE

PLATE NO.

STD. NO.

7-11

Rev. 1-05, 2011 Reprint

APPENDIX H.6

Inlet Marking Specification

Master artwork may not be reproduced without the prior written consent of das.

© 2012 das Manufacturing, Inc.

4" / COLORS: 286 BLUE, 349 GREEN, 116 YELLOW



JW PROOF #1 DAS P.N.4.0 GMU-DC/03-06-2012.

APPENDIX H.7

Concrete Washout Specification

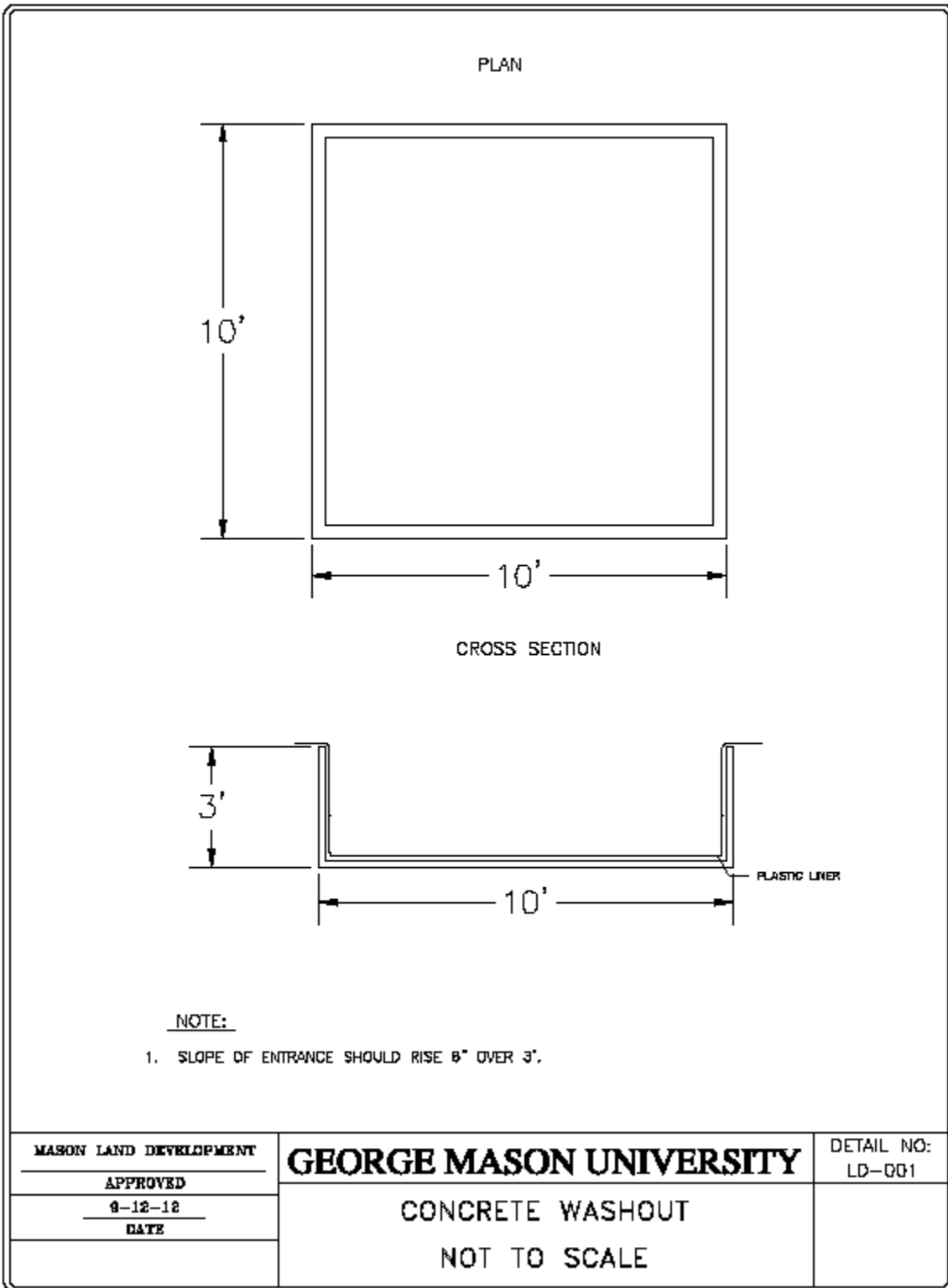

APPENDIX H.8

Permanent Check Dam Specification

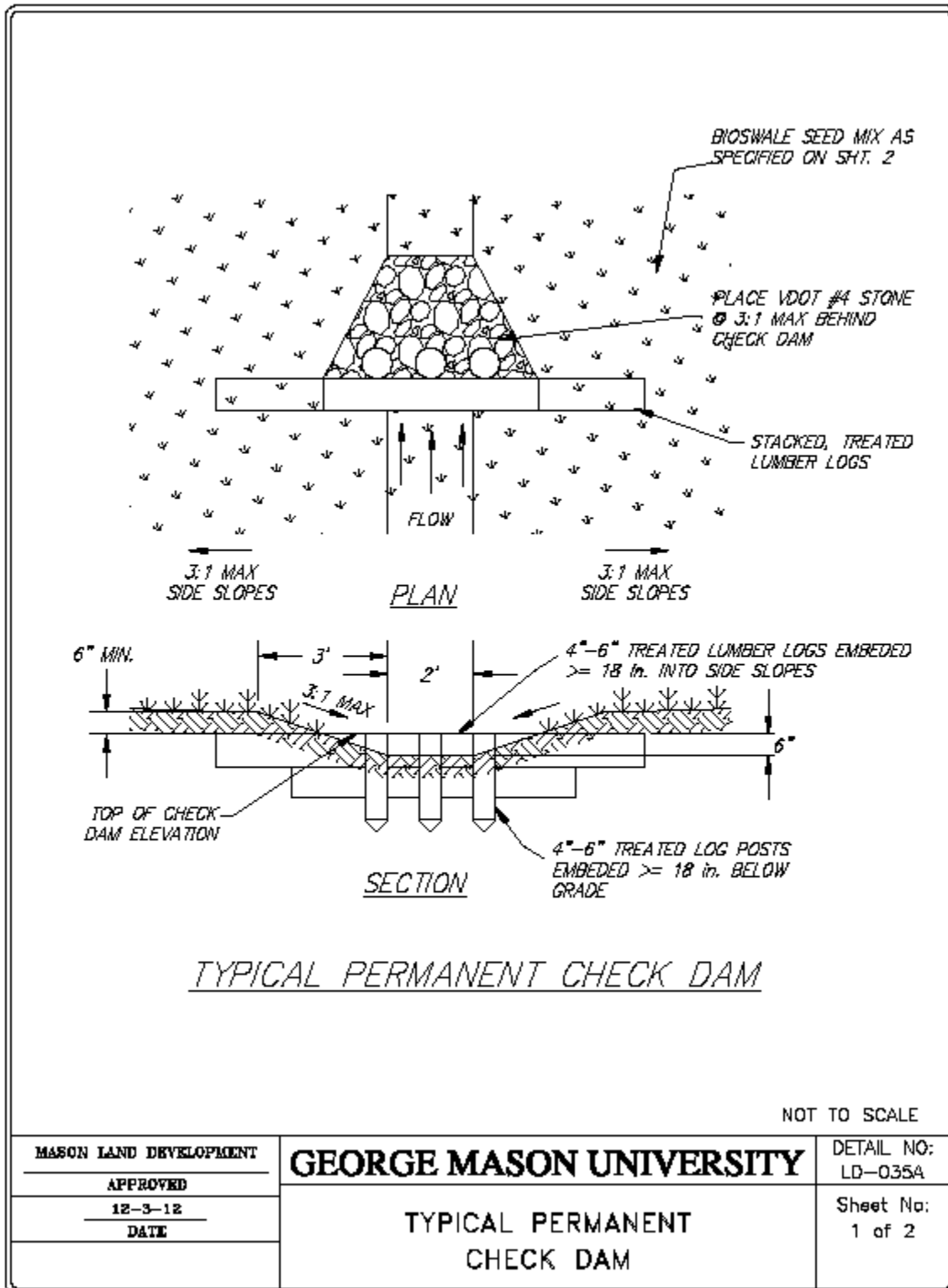

SEED MIXTURE: ERNST CONSERVATION SEED MIX ERNMX-178 (OR EQUAL AS APPROVED BY GMU):

- 10% FOX SEDGE (*CAREX VULPINOIDEA*)
- 8% VIRGINIA WILD RYE (*ELYMUS VIRGINICUS*)
- 8% RIVERBANK WILD RYE (*ELYMUS RIPARIUS*)
- 8% DEER TONGUE, "TOGA" (*PANICUM CLANDESTINUM*)
- 8% LITTLE BLUESTEM (*SCHIZACHRYUM SCOPARIUM*)
- 7% INDIANGRASS (*SORGHASTRUM NUTANS*)
- 6% PARTRIDGE PEA (*CHAMAECRISTA FASCICULATA*)
- 5% BLUE VERVAIN (*VERBENA HASTATA*)
- 5% BIG BLUESTEM, "NIAGRA" (*ANDROPOGON GERARDII*)
- 4% SWITCHGRASS, "SHAWNEE" (*PANICUM VIRGATUM*)
- 4% SILKY DOGWOOD (*CORNUS AMOMUM*)
- 2% GRASS LEAVED GOLDENROD (*EUTHAMIA GRAMINIFOLIA*)
- 2% ARROW WOOD (*VIBURNUM DENTATUM*)
- 2% OX EYE SUNFLOWER (*HELIOPSIS HELIANTHOIDES*)
- 2% BLACK EYED SUSAN (*RUDBECKIA HIRTA*)
- 2% STAGHORN SUMAC (*RHUS TYPHINA*)
- 2% WILD BERGAMOT (*MONARDA FISTULOSA*)
- 2% JOE PYE WEED (*EUPATORIUM FISTULOSUM*)
- 2% SPOTTED JOE PYE WEED (*EUPATORIUM MACULATUM*)
- 2% TALL WHITE BEARD TONGUE (*PENSTEMON DIGITALIS*)
- 2% COMMON MILKWEED (*ASCLEPIAS SYRIACA*)
- 2% SOFT RUSH (*JUNCUS EFFUSUS*)
- 2% BONESET (*EUPATORIUM PERFOLIATUM*)
- 1% BLUE FALSE INDIGO (*BAPTISIA AUSTRALIS*)
- 1% COMMON SNEEZEWEED (*HELENIUM AUTUMNALE*)
- 1% GIANT IRONWEED (*VERNONIA GIGANTEA*)

NOT TO SCALE

MASON LAND DEVELOPMENT	GEORGE MASON UNIVERSITY	DETAIL NO: LD-035B
APPROVED <u>12-8-12</u> DATE		Sheet No: 2 of 2
	TYPICAL PERMANENT CHECK DAM	

APPENDIX H.9

GUTTERGATOR® Specification For Curb Gutter Storm Drains or equal substitute

1.0 Description

- 1.1 This work shall consist of furnishing, placing, maintaining and removing the GutterGator sediment control device as directed by the engineer and as shown on the contract drawings. The GutterGator sediment control system manufactured by:

*ACF Environmental, Inc.
2831 Cardwell Road
Richmond, Virginia 23234
Phone: 800-448-3636 * Fax: 804-743-7779
www.acfenvironmental.com*

2.0 Materials

2.1 GUTTERGATOR

- 2.1.1 The GutterGator will be manufactured to 3' molds in 3', 6', 9', 12', 15' and 18' lengths and a minimum of twenty-four (24) inches longer than the curb inlet opening. This will allow for sufficient length to cover the inlet with twelve (12) inches beyond the inlet on both ends.

3.0 Construction Sequence

3.1 General

- 3.1.1 Install the GutterGator in front of the curb inlet opening. Drop 7lb weight sock into inlet opening, secure tie back straps, if applicable. Each end of the GutterGator should overlap the curb inlet approximately 12".
- 3.1.2 The GutterGator should be cleaned if a visual inspection shows sediment and debris build up around the GutterGator.
- 3.1.3 To remove the GutterGator, lift out of curb opening with provided carrying handle.
- 3.1.4 Clean as needed. Store out of direct sunlight.
- 3.1.5 Ponding is likely if sediment is not removed

regularly. Inspection of GutterGator should be on a regular basis and immediately after wet Weather.

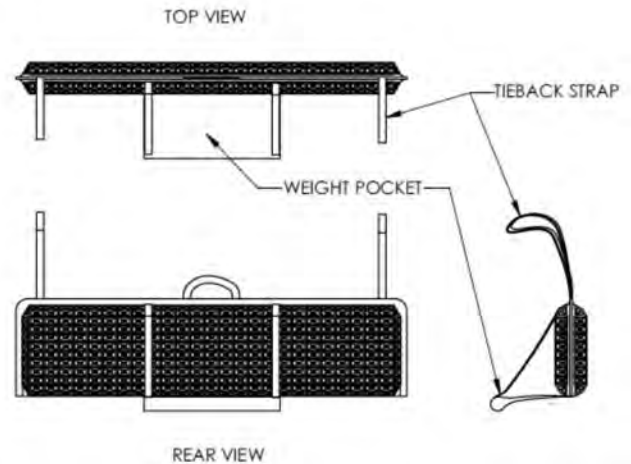

Available in Virginia from:
ACF Environmental
"Complete Source for Storm Water Solutions"

Distributed by:
2831 Cardwell Road Richmond, Virginia 23234
(800) 644-9223 (800) 448-3636 Voice
(804) 743-7779 Fax
•www.thebmpstore.com
www.acfenvironmental.com

APPENDIX I:

Specifications

APPENDIX I.1: PLANTING SOILS

PART 1 – GENERAL

1.1 RELATED DOCUMENTS

- A. Drawings and general provisions of the Contract, including General and Supplementary Conditions and Division 1 Specification Sections, apply to this Section.

1.2 SUMMARY

- A. This Section includes the following:
 1. Preparing and reshaping subgrade into planting subsoil.
 2. Amending and spreading existing soils.
 3. Importing and spreading soils.
 4. Edging to landscape soil areas.
 5. Finish grading.
 6. Landscape soil reinforcing/stabilizing.
 7. Landscape soil erosion control.
 8. Inorganic mulching.

1.3 REFERENCED STANDARDS

- A. American Society for Testing and Materials:
 1. ASTM C136-84a - Method for Sieve Analysis of Fine and Coarse Aggregates.
 2. ASTM D422-63 (1972) - Method for Particle Size Analysis of Soils
 3. ASTM D2607-69 - Classification of Peats, Mosses, Humus, and Related Products.
 4. ASTM D2974-84 - Test Method for Moisture, Ash, and Organic Matter of Peat Materials.
 5. ASTM D2976-71 (1981) - Test Method for pH of Peat Materials.
 6. ASTM D5268-92 - Standard Specification for Topsoil Used for Landscaping Purposes.
- B. United States Department of Agriculture:
 1. USDA Soil Particle Size & Texture Classes.
- C. Association of Official Agricultural Chemists:
 1. AOAC Standards.

1.4 DEFINITIONS

- A. Finish Grade: Elevation of finished surface.
- B. Planting Topsoil: Proposed upper horizon of soil in planting areas that may or may not contain a large proportion of Topsoil. If conforming, sources may include existing topsoil

un-amended or amended, imported topsoil amended or un-amended and manufactured and/or imported soil mixes amended or un-amended. Planting Topsoil shall consist of the same base material as the Planting Subsoil except with additional organic matter worked into it.

- C. Planting Subsoil: Proposed lower horizon of soil in planting areas between the Planting Topsoil and the Subgrade. If conforming, sources can include existing subsoil un-amended or amended; existing subgrade un-amended or amended, manufactured and/or imported subsoil amended.
- D. Planting Soils: Proposed Planting Soil profile made up of amended Subgrade, Planting Subsoil, Planting Topsoil and Mulch layer.
- E. Topsoil: Surface 'A' horizon from natural or cultivated surface profile (not including bogs or wetlands) containing organic matter, sand, silt, and clay particles. It shall be friable, pervious, and black or a darker shade of brown, gray, or red than underlying subsoil. It shall be free of subsoil, clay lumps, gravel, and other objects more than 2 inches (50 mm) in diameter; and free of weeds, roots, and other deleterious materials. Percentage by mass and pH shall meet ASTM D5268-92 specification (table 1).
- F. Subsoil: Lower 'B' horizon from a natural or cultivated soil profile (not including bogs or wetlands) containing less organic matter than overlying topsoil.
- G. Subgrade: Surface or elevation remaining after completing excavation, or top surface of a fill or backfill immediately below sub-base, drainage fill, or topsoil materials. Subgrade resulting from
Earthworks may or may not be suitable for plant growth and shall be amended.

1.5 SYSTEM DESCRIPTION

- A. Design Requirement: Test, adapt and refine Planting Soil mix design to suit the performance requirements, locally available materials, project site conditions, mock up performance and the Mason LD's review. Mix design includes but is not limited to the proportion of components, amendment types and their application rates.
- B. Performance Requirement: Be responsible for all means, techniques and methods to achieve the soil characteristics specified.

1.6 SUBMITTALS

- A. Suppliers and Subcontractors: Submit written particulars of all proposed suppliers before ordering of materials.

- B. Supply Difficulties: Notify Mason immediately if any supply difficulties are encountered. No extension of time will be granted if any material or product is not available because of late ordering.
- C. Alternatives: Submit list of proposed alternative materials within 14 days of contract award. Alternatives shall not be permissible after this time.
- D. Product Data: For manufactured products submit data sheets with samples.
- E. Qualifications: Submit qualifications of proposed testing laboratory for approval before sampling.
- F. Samples for Verification: For each of the following:
 - 1. 5 lb (2.2 kg) of each type of proposed Planting Soil required, in labeled plastic bags showing sample name, location and date. Submit at least 28 days prior to ordering or processing. Submit only samples that conform as evidenced by the Soil Reports.
 - 2. 5 lb (2.2 kg) of mulch for each color and texture required, in labeled plastic bags.
 - 3. Edging materials and accessories, of manufacturer's standard size, to verify color selected.
- G. Source Quality Control - Soils Report:
 - 1. Planting Subsoil & Planting Topsoil - For each proposed type, submit Soils Report describing all components, composition, amendments, test results, analysis, trial results and interpretations and source location at least 28 days prior to ordering or processing.
- H. Field Quality Control - Soils Report:
 - 1. Amended Subgrade - For each type, submit test results at least 14 days prior to planting.
 - 2. Planting Soils - For each placed type, submit test results showing compliance of soils after the first area is planted but before soil is spread in remaining areas.
- I. Approval by Mason LD of submitted product data, samples, test reports, and certificates, shall not constitute final acceptance.

1.7 QUALITY ASSURANCE

- A. Soil-Testing Laboratory Qualifications: Laboratory shall be an approved independent laboratory, recognized by the local State Department of Agriculture, with the experience and capability to conduct the testing indicated and that specializes in types of tests to be performed. Provide the laboratory with representative samples and a copy of the Contract Document Planting Plans, Schedules and Specifications. Test, analyze and interpret in accordance with current AOAC standards.
- B. Soil Reports: As a minimum include the following in each Soil Report;

1. Sampling: Methods used to achieve a true representation of soil variability.
 2. Soil Analysis: Test for the specified characteristics. USDA Texture shall be tested to ASTM D 422-63 and presented in graph form. Continue to sample and retest until each proposed soil type conforms to the specified characteristics. Contractor to pay for all such testing.
 3. All topsoil shall be tested by a recognized laboratory for the following criteria:
 - a. Organic matter content shall be not less than 1.5% by weight.
 - b. pH range shall be from 6.25-6.5. If pH is less than 6.25, lime shall be added in accordance with soil test results or in accordance with the recommendations of the vegetative establishment practice being used.
 - c. Soluble salts shall not exceed 500 ppm.
 - d. If additional off-site topsoil is needed, it must meet the standards stated above.
 4. Interpretation: Report on suitability of each proposed soil type for growing plants indicated on the Plant Schedule and propose recommended quantities of amendments to be added to produce conforming soils. Substantiate with data and/or research any proposed alternatives.
 5. Liming: Where the pH of the subsoil is 6.0 or less, or the soil is composed of heavy clays, agricultural limestone shall be spread in accordance with the soil test or the vegetative establishment practice being used.
 6. Bonding: After the areas to be topsoiled have been brought to grade, and immediately prior to dumping and spreading the topsoil, the subgrade shall be loosened by discing or scarifying to a depth of at least 2 inches to ensure bonding of the topsoil and subsoil.
- C. Amendment Trial: If amendments or modifications are proposed to soils, perform trials and retest to show conformance prior to finalizing Soil Reports. Undertake trial amendments or modifications with same methods, techniques and/or equipment as proposed for execution.
1. Minimum Trial volume for each soil type – 5 cubic yards.
 2. Perform amendment trials for both soils stored offsite and on-site soils.
- D. Independent Tests: Mason reserves to right to have soil tested independently at the Mason's cost.
- E. Shop Drawings: Submit calculations, site layout drawings and anchoring details of Cellular Confinement System in accordance with Manufacturer's written recommendations specific to the project application.
- F. Field Observation: Give not less than 10 working days' notice so that field observations may be made of the following:
1. Prepared Planting Subsoil prior to spreading Planting Topsoil.
 2. Fine grading operations.

- G. Surveyor Qualifications: An independent licensed surveyor, acceptable to authorities having jurisdiction and experienced in ground surveys.

1.8 DELIVERY, STORAGE, AND HANDLING

- A. Prevent spillage when hauling on or adjacent to Mason's property. In the event that spillage occurs, remove all spillage and sweep, wash, or otherwise clean such streets or open areas as required by State Authorities.
- B. Take precautions to prevent a dust nuisance to adjacent public or private properties and to prevent erosion and transportation of soil to downstream or adjacent properties due to work under this Contract. At project site exit, clean dirt from tires. Do not track dirt out of construction area.
- C. Prior to delivery, propose suitable stockpile locations. Stockpile to a 6-foot high maximum and protect from traffic, wind and water erosion. Provide temporary seeding and/or erosion control measures as approved by the Mason LD. Topsoil shall be stockpiled in such a manner that natural drainage is not obstructed and no off-site sediment damage shall result. Stabilize or protect stockpiles in accordance with MS #2. Perimeter controls must be placed around the stockpile immediately; seeding of stockpiles shall be completed within 7 days of the formation of the stockpile, in accordance with Std. & Spec. 3.31, TEMPORARY SEEDING if it is to remain dormant for longer than 14 days (refer to MS #1 and MS #2).
- D. Protect inorganic mulch from contamination by foreign materials. Isolate stockpiles to prevent mixing of different aggregate grades. Prevent contamination by organic materials.
- E. Use quality control sampling and testing to ensure that delivered materials match the approved samples/mockups and the specified criteria.
- F. Before Planting Soils are redistributed from stockpiles, ensure a uniform mix of soils, free of subgrade lenses and other irregularities.

1.9 PROJECT CONDITIONS

- A. Existing Soil Tests: Soil testing (geotechnical) for design purposes has been prepared for the Mason. This information is not intended as a representation, or to warranty the continuity, of such conditions between soil tests. The Mason shall not be responsible for interpretations or conclusions drawn therefrom. The data is made available only for information and not for construction. Make any additional tests and other exploratory operations at no cost to Mason.
- B. Existing Soil Volumes: The Mason may have existing soil that may be suitable for reuse. Mason shall not be responsible for interpretations or conclusions drawn concerning the actual volume of conforming soil that may be recovered nor the volume of actual

unsuitable material remaining. Make any additional tests and other exploratory operations at no cost to Mason.

1.10 SEQUENCING

- A. Coordination with Utilities: Ensure the works are staged and sequenced to:
 - 1. Minimize tracking of equipment and compaction of planting areas. Compacted soil must be reworked to comply with specifications.
 - 2. Prevent mixing, contamination or reversing soil profile from utility excavations and back filling. Repair any disturbance to the soil layers after placing to comply with the specified requirements.
- B. Slopes Steeper than 1 in 3:
 - 1. Complete all work on slopes (irrigation pipes, soil, erosion control etc.) before surrounding flatter areas are prepared for Planting Soil.

1.11 COORDINATION

- A. Coordinating stockpiles: Be responsible for any necessary temporary storage and staging of soil works including relocating stockpiles to accommodate the scheduling of other work.

PART 2 – PRODUCTS

2.1 PLANTING SOILS GENERALLY

- A. Allowed Sources:
 - 1. Reuse existing soils stockpiled on-site. Verify suitability of stockpiled soil to produce Planting Soil Profile including but not limited to amendments, raking and/or screening.
 - 2. Supplement with imported or manufactured soils from off-site sources when quantities are insufficient.
 - 3. Import soil or manufactured soil from off-site sources.
 - 4. Amend existing in-place soils to produce Planting Soils. Verify suitability of stockpiled soil to produce Planting Soil including but not limited to amendments, raking and/or screening.
- B. Disallowed Sources:
 - 1. Do not use soil from USDA Classified Prime Farmland.
- C. Blending and Batching: Ensure Planting Soil has uniform color and texture for each vegetation type and blend materials uniformly and thoroughly incorporate soil amendments to assure uniform distribution. For each soil type, use only a single supply source for the entire quantity required.
- D. All planting soils shall be free from gravel and debris.

2.2 AMENDED SUBGRADE

A. Amended Subgrade Characteristics: As applicable, amended subgrade shall conform to the following characteristics.

Property	Unit	Amended Subgrade
Physical		
Bulk density – moist	lb/ft ³ (kg/m ³)	< (1600)
Organic content - dry	%mass	1 - 2
Solid materials size	inch(mm)	< 4 (100)
Solid materials content	%Vol	< 20
Infiltration	inch/hr.	1 to 3
Chemical		
pH	CaCl ₂	5-6.5
EC	dS/m	< 2
Toxins		
Oil		No visual evidence in top 6 inches

Property	Unit	Common to each horizon	Type 1 Planting Subsoil	Type 1 Planting Topsoil
Physical				
Texture by particle size distribution analysis	USDA		sandy loam	Loam to sandy loam
Air filled porosity	%Vol		5 - 25	10 - 25
Bulk density - dry	lb/ft ³ (kg/m ³)	NA		
Bulk density - moist	lb/ft ³ (kg/m ³)	<90 (1440)		
Organic content - dry	%mass		1 - 2	4 - 5
Solid materials size	inch(mm)	< 0.5 (13)		
Solid materials content	%Vol	< 5		
Water stable aggregation	%	>30		
Infiltration	inch/hr	1 to 3		
Temperature	°C	NA		
Chemical				
pH	CaCl ₂	5-6.5		
EC	dS/m	< 2		
Cg / Mg	ratio	3 to 6		
CEC cation exch. Capacity	meq%	5 to 20		
ESP exch. Sodium	%	< 5		
SAR	ratio	< 6		
N nitrogen as ammonium	ppm	6 to 24		
N nitrogen as nitrate	ppm	30 to 100		
P phosphorus	ppm	3 to 18		
K potassium	ppm	25 to 110		
S sulphur	ppm	< 200		
Cu copper	ppm	0.4 to 6		
Zn zinc	ppm	0.3 to 10		
Mn manganese	ppm	3 to 15		
Fe iron	ppm	3 to 20		
B boron	ppm	0.3 to 1		
Odor		no strong odor		
Toxins				
Heavy metals & toxins	ppm	< EPA & Local State acceptable levels		
Biological				
Micro organisms other than parasitic nematodes		present		
Mycorrhiza fungi		present		
Fungal diseases		absent		
Weed viable reproductive parts		absent		

Planting Soil component proportions by volume:

1. For Broadleaves
 - a. 40% Existing subsoil
 - b. 45% Imported topsoil & sand
 - c. 15% Organic amendment
2. For Conifers
 - a. 10% Existing subsoil
 - b. 65% Imported topsoil & sand
 - c. 25% Organic amendment
3. For Grass Areas
 - a. 1 inch compost missed homogenously into top 6 inches of subsoil on site.

B. Planting Soil component proportions by volume:

1. Topsoil 40%
2. Sand 10%
3. Peat 20%
4. Compost 10%

-
5. Wood Derivatives 20%
 6. To each cubic yard of mix add:
 - a. Amendments as required by the Soils Report.
- C. Planting Soil component proportions by volume:
1. For Planting Subsoil
 - a. 100% Imported Topsoil or Subsoil
 2. For Planting Topsoil
 - a. 90% minimum Planting Subsoil amended with,
 - b. 10% maximum composted organic matter,
 - c. Other amendments to suit species as identified in the Soils Report.

- A. Planting Soil Characteristics: Placed Planting Soils shall conform to the following characteristics.

Property	Unit	Common to each horizon	Type 2 Planting Subsoil	Type 2 Planting Topsoil
Physical				
Texture by particle size distribution analysis	USDA		Medium loamy sand	Coarse loamy sand
Air filled porosity	%Vol	10 - 25		
Bulk density - dry	lb/ft ³ (kg/m ³)	NA		
Bulk density - moist	lb/ft ³ (kg/m ³)	<90 (1440)		
Organic content - dry	%mass		0 - 1	4 - 5
Solid materials size	inch(mm)	< 0.5 (13)		
Solid materials content	%Vol	< 5		
Water stable aggregation	%	>30		
Infiltration	inch/hr	1 to 3		
Temperature	°C	NA		
Chemical				
pH	CaCl ₂	5-6.5		
EC	dS/m	< 2		
Cg / Mg	ratio	3 to 6		
CEC cation exch. Capacity	meq%	5 to 20		
ESP exch. Sodium	%	< 5		
SAR	ratio	< 6		
N nitrogen as ammonium	ppm	6 to 24		
N nitrogen as nitrate	ppm	30 to 100		
P phosphorus	ppm	3 to 18		
K potassium	ppm	25 to 110		
S sulphur	ppm	< 200		
Cu copper	ppm	0.4 to 6		
Zn zinc	ppm	0.3 to 10		
Mn manganese	ppm	3 to 15		
Fe iron	ppm	3 to 20		
B boron	ppm	0.3 to 1		
Odor		no strong odor		
Toxins				
Heavy metals & toxins	ppm	< EPA & Local State acceptable levels		
Biological				
Micro organisms other than parasitic nematodes		present		
Mycorrhiza fungi		present		
Fungal diseases		absent		
Weed viable reproductive parts		absent		

- B. Component proportions by volume:
1. For Planting Subsoil: 100% Imported Topsoil or sand/topsoil mix.
 2. For Planting Topsoil
 - a. 90% minimum Planting Subsoil amended with,
 - b. 10% maximum composted organic matter,
 - c. Other amendments to suit species as identified in the Soils Report.

2.5 PLANTING SOILS TYPE 3 – SHRUB & GROUND COVER AREAS

- A. Planting Soil Characteristics: Placed Planting Soils shall conform to the following characteristics.

Property	Unit	Common to each horizon	Type 3 Planting Subsoil	Type 3 Planting Topsoil
Physical				
Texture by particle size distribution analysis	USDA		Silt loam to fine sandy loam	Silt loam to fine sandy loam
Air filled porosity	%Vol	5 - 25		
Bulk density - dry	b/ft ³ (kg/m ³)	NA		
Bulk density - moist	lb/ft ³ (kg/m ³)	<90 (1440)		
Organic content - dry	%mass		0 - 1	10 - 15
Solid materials size	inch(mm)	< 1 (25)		
Solid materials content	%Vol	< 5		
Water stable aggregation	%	>30		
Infiltration	inch/hr	1 to 3		
Temperature	°C	NA		
Chemical				
pH	CaCl ₂	5-6.5		
EC	dS/m	< 2		
Cg / Mg	ratio	3 to 6		
CEC cation exch. Capacity	meq%	5 to 20		
ESP exch. Sodium	%	< 5		
SAR	ratio	< 6		
N nitrogen as ammonium	ppm	6 to 24		
N nitrogen as nitrate	ppm	30 to 100		
P phosphorus	ppm	3 to 18		
K potassium	ppm	25 to 110		
S sulphur	ppm	< 200		
Cu copper	ppm	0.4 to 6		
Zn zinc	ppm	0.3 to 10		
Mn manganese	ppm	3 to 15		
Fe iron	ppm	3 to 20		
B boron	ppm	0.3 to 1		
Odor		no strong odor		
Toxins				
Heavy metals & toxins	ppm	< EPA & Local State acceptable levels		
Biological				
Micro organisms other than parasitic nematodes		present		
Mycorrhiza fungi		present		
Fungal diseases		absent		
Weed viable reproductive parts		absent		

- B. Planting Soil component proportions by volume:
1. For Planting Subsoil: 100% Imported Topsoil.
 2. For Planting Topsoil
 - a. 80% minimum Planting Subsoil amended with,
 - b. 20% maximum composted organic matter,
 - c. Other amendments to suit species as identified in the Soils Report.

2.6 PLANTING SOILS TYPE 4 – UNDER PAVING USE

- A. Planting Soil Characteristics: Placed Planting Soils shall conform to the following characteristics.

.Property	Unit	Common to each horizon	Type 4 Planting Subsoil	Type 4 Planting Topsoil
Physical				
Texture by particle size distribution analysis	USDA		Very coarse to coarse loamy sand	Gravel #2
Air filled porosity	%Vol		5 - 25	25 plus
Bulk density - dry	lb/ft3 (kg/m3)		<67 (1072)	
Bulk density - moist	lb/ft3 (kg/m3)		<90 (1440)	NA
Organic content - dry	%mass		2 - 3	
Solid materials size	inch(mm)	< 1 (25)		
Solid materials content	%Vol	< 5		
Water stable aggregation	%	>30		
Infiltration	inch/hr	2 to 3		
Temperature	oC	NA		
Chemical				
pH	CaCl ₂	5-6.5		
EC	dS/m	< 2		
Cg / Mg	ratio	3 to 6		
CEC cation exch. Capacity	meq%	5 to 20		
ESP exch. Sodium	%	< 5		
SAR	ratio	< 6		
N nitrogen as ammonium	ppm	6 to 24		
N nitrogen as nitrate	ppm	30 to 100		
P phosphorus	ppm	3 to 18		
K potassium	ppm	25 to 110		
S sulphur	ppm	< 200		
Cu copper	ppm	0.4 to 6		
Zn zinc	ppm	0.3 to 10		
Mn manganese	ppm	3 to 15		
Fe iron	ppm	3 to 20		
B boron	ppm	0.3 to 1		
Odor		no strong odor		
Toxins				
Heavy metals & toxins	ppm	< EPA & Local State acceptable levels		
Biological				
Micro organisms other than parasitic nematodes		present		
Mycorrhiza fungi		present		
Fungal diseases		absent		
Weed viable reproductive parts		absent		

- B. Planting Soil component proportions by volume:
1. For Planting Subsoil
 - a. 94% Imported Sands amended with,
 - b. 6% stable peat,
 - c. Other amendments to suit species as identified in the Soils Report.
 2. For Planting Topsoil
 - a. 100% imported clean-washed neutral pH gravel #2.

2.7 PLANTING SOILS TYPE 5 – LIGHTWEIGHT

- A. Planting Soil Characteristics: Placed Planting Soils shall conform to the following characteristics.

Property	Unit	Common to each horizon	Type 5 Planting Subsoil	Type 5 Planting Topsoil
Physical				
Texture by particle size distribution analysis	USDA		sand	Loamy sand
Air filled porosity	%Vol	10 - 25		
Bulk density - dry	lb/ft ³ (kg/m ³)	<67 (1072)		
Bulk density - moist	lb/ft ³ (kg/m ³)	<90 (1440)		
Organic content - dry	%mass		4 - 6	10 - 20
Solid materials size	inch(mm)	< 0.5 (13)		
Solid materials content	%Vol	< 5		
Water stable aggregation	%	>30		
Infiltration	inch/hr	2 to 3		
Temperature	°C	< 40		
Chemical				
pH	CaCl ₂	5-6.5		
EC	dS/m	< 2		
Cg / Mg	ratio	3 to 6		
CEC cation exch. Capacity	meq%	5 to 20		
ESP exch. Sodium	%	< 5		
SAR	ratio	< 6		
N nitrogen as ammonium	ppm	6 to 24		
N nitrogen as nitrate	ppm	30 to 100		
P phosphorus	ppm	3 to 18		
K potassium	ppm	25 to 110		
S sulphur	ppm	< 200		
Cu copper	ppm	0.4 to 6		
Zn zinc	ppm	0.3 to 10		
Mn manganese	ppm	3 to 15		
Fe iron	ppm	3 to 20		
B boron	ppm	0.3 to 1		
Odor		no strong odor		
Toxins				
Heavy metals & toxins	ppm	< EPA & Local State acceptable levels		
Biological				
Micro organisms other than parasitic nematodes		present		
Mycorrhiza fungi		present		
Fungal diseases		absent		
Weed viable reproductive parts		absent		

B. Planting Soil component proportions by volume

1. fine sand 40%
2. fir bark 20%
3. perlite 30%
4. peat moss 10%
5. To each cubic yard add:
 - a. Amendments as required by the Soils Report.
6. Void Filler: high-density polystyrene blocks with a minimum compressive strength of 60 pounds per square inch.
7. Maximum weight: 90 pounds per cubic foot when saturated with water.

C. Planting Topsoil mix proportions by volume:

1. Expanded clay/shale 45%

2. Gap graded sand 45%
3. Pine bark 10%
4. To each cubic yard add:
 - a. Other amendments as required by the Soils Report.
5. Void Filler: high-density polystyrene blocks with a minimum compressive strength of 60 pounds per square inch.
6. Maximum weight: 90 pounds per cubic foot when saturated with water.

2.8 INORGANIC PLANTING SOIL AMENDMENTS

- A. Amendments: Use amendments to make the soil conform to the specified requirements. Use amendment types as recommended by the Soils Report.
- B. Lime: ASTM C 602, agricultural limestone containing a minimum 85 percent calcium carbonate equivalent and as follows:
 1. Class: Class T, with a minimum 99 percent passing through No. 8 (2.36-mm) sieve and a minimum 75 percent passing through No. 60 (0.25-mm) sieve.
 2. Provide lime in form of dolomitic limestone.
- C. Sulfur: Granular, biodegradable, containing a minimum of 90 percent sulfur, with a minimum 99 percent passing through No. 6 (3.35-mm) sieve and a maximum 10 percent passing through No. 40 (0.425-mm) sieve.
- D. Iron Sulfate: Granulated ferrous sulfate containing a minimum of 20 percent iron and 10 percent sulfur.
- E. Aluminum Sulfate: Commercial grade, unadulterated.
- F. Perlite: Horticultural perlite, soil amendment grade. Handle to avoid breaking or crushing particles.
- G. Agricultural Gypsum: Finely ground, containing a minimum of 90 percent calcium sulfate.
- H. Sand: Clean, washed, sharp, natural or manufactured, free of toxic materials. The saturation extract conductivity shall not exceed 3.0 millimhos/cm. The concentration of boron in the saturation extract shall not exceed 1.0 ppm. The sodium adsorption ratio (SAR) as calculated from analysis of the saturation extract shall not exceed 6.0.
 1. Percent Passing

Percent Passing	Sieve Size
a. 100	4.76mm (#4,4mesh)
b. 95 – 100	1.00mm (#18,16mesh)
c. 65 – 100	500 micron (#35, 32mesh)
d. 0 – 10	53 micron (#270,270mesh)

- I. Gravel: Clean, washed, sharp, natural or manufactured, free of toxic materials. #2 size from granite or sandstone parent material not limestone or marble.
- J. Diatomaceous Earth: Calcined, diatomaceous earth, 90 percent silica, with approximately 140 percent water absorption capacity by weight.
- K. Expanded Shale: Chemically inert, neutral pH, 1/6 inch to 1/2 inch.
- L. Zeolites: Mineral clinoptilolite with at least 60 percent water absorption by weight.
- M. Water: Clean, fresh and free from harmful materials. If Mason's potable water supply is used, meter and pay for quantity used by the Contractor.

2.9 ORGANIC SOIL AMENDMENTS

- A. Amendments: Use amendments to make the soil conform to the specified requirements. Use amendment types as recommended by the Soils Report. Compost: Well-composted, stable, and weed-free organic matter, pH range of 5.5 to 8; moisture content 35 to 55 percent by weight; 100 percent passing through 1/2-inch (13-mm) sieve; soluble salt content of 5 to 10 decisiemens/m; not exceeding 0.5 percent inert contaminants and free of substances toxic to plants; and as follows:
 - 1. Organic Matter Content: 50 to 60 percent of dry weight.
 - 2. Feedstock: Agricultural, food, or industrial residuals; biosolids; yard trimmings; source separated or compostable mixed solid waste.
 - 3. Carbon/Nitrogen Ratio: less than 25:1.
 - 4. EPA Grade A.
- B. Peat: Finely divided or granular texture, with a pH range of 6 to 7.5, containing partially decomposed moss peat, native peat, or reed-sedge peat and having a water-absorbing capacity of 1100 to 2000 percent.
- C. Wood Derivatives: Decomposed, nitrogen-treated sawdust, ground bark, or wood waste; of uniform texture, free of chips, stones, sticks, soil, or toxic materials.
 - 1. In lieu of decomposed wood derivatives, mix partially decomposed wood derivatives with at least 0.15 lb (2.4 kg) of ammonium nitrate or 0.25 lb of ammonium sulfate per cubic foot of loose sawdust or ground bark.
 - 2. Damp composted for at least 12 weeks prior to use.
 - 3. The saturation extract conductivity shall not exceed 3.0 millimhos/cm at 25oC.
- D. Manure: Well-rotted, unbleached, stable or cattle manure containing not more than 15 percent by volume of straw, sawdust, or other bedding materials; free of toxic substances,

stones, sticks, soil, weed seed, and material harmful to plant growth. Age manure between one and two years before use.

1. Milorganite or other human-derived manure products not allowed.

2.10 FERTILIZER

- A. Fertilizer application shall conform to the Mason's current approved Nutrient Management Plan.
- B. Bone meal: Commercial, raw or steamed, finely ground; a minimum of 4 percent nitrogen and 20 percent phosphoric acid.
- C. Superphosphate: Commercial, phosphate mixture, soluble; a minimum of 20 percent available phosphoric acid.
- D. Commercial Fertilizer: Commercial-grade complete fertilizer of neutral character, consisting of fast- and slow-release nitrogen, 50 percent

2.11 SOURCE QUALITY CONTROL

- A. Testing Agency: Engage a qualified independent testing agency to perform quality control testing.
- B. Sampling: Visually inspect soils on the surface and in core holes and take samples to reflect the maximum range of variability in each type of soil from each source.
 1. Random sampling is not permitted.
 2. Composite sampling is only permitted if soil source has undergone mixing during stockpiling.
 3. Take a large enough sample for each different test required.
- C. Test for specified characteristics of each soil type from each source.
- D. If testing agency reports that soils have not achieved specified requirements rework and retest until specified characteristics are obtained. Proceed with subsequent soil work only after test results for previously completed work comply with requirements.

2.12 LANDSCAPE SOIL REINFORCING

- A. Non-degradable Cellular Confinement System: UV stabilized black PE cells
 1. Requirement: 6 inches deep and larger than 16 inches wide with perforated walls. Provide necessary data for manufacturer to recommend appropriate anchoring materials and installation methods.
 2. Manufacturer: Subject to compliance with requirements, provide products by one of the following:
 - a. Presto Geosystems: Geoweb Cellular Confinement System, www.prestogeo.com.

- b. Nilex Geo-Cel Cellular Confinement System, www.nilex.com.
- B. Non-degradable Mat System: Black nylon three-dimensional geo-matrix of fused filaments creating an open mat.
- 1. Requirement: Minimum thickness of 0.75 inches. Provide necessary data for Manufacturer to recommend appropriate anchoring materials and installation methods.
 - 2. Manufacturer: Subject to compliance with requirements, provide products by one of the following:
 - a. Akzo Industrial Systems -“Enkamat 7020”.
 - b. Or equivalent, as accepted by Mason.
- C. Non-degradable Cellular Paver Systems: UV stabilized Green recycled HDPE cellular paver blocks with minimum thickness of 1 ¼ inches.
- 1. Requirement: Minimum strength of 61,000 lbs per sf 27,700 kgs/0.09m². Provide necessary data for Manufacturer to recommend appropriate anchoring materials and installation methods.
 - 2. Manufacturer: Subject to compliance with requirements, provide products by one of the following:
 - a. Barton Corporation -“Grassroad Pavers Plus”.
 - b. Landscape Products Company - “Grass-Cel”.
 - c. Invisible Structures Inc. – “Grass-Pave2”.
 - d. Or equivalent, as accepted by Mason.
- D. Non-degradable Fiber Reinforcing Systems:
- 1. Manufacturer: Subject to compliance with requirements, provide products by one of the following:
 - a. Turfgrids Root Zone Mix polypropylene fibers, as manufactured by Stabilizer Inc., 2218 Magnolia Street, Phoenix, AZ 85034, (800) 336-2468.
 - b. Netlon – “Relexmesh”.
 - c. Or equivalent, as accepted by Mason.
- E. Non-degradable Mesh Reinforcing Systems:
- 1. Manufacturer: Subject to compliance with requirements, provide products by one of the following:
 - a. Tensar – “Geogrid BX1100”.
 - b. Or equivalent, as accepted by Mason.

2.13 CRUSHED STONE MULCH

- A. Crushed Stone: Decomposed granite or crushed granite aggregate less than. inch free from clay lumps, organic matter, and deleterious material.
- 1. Color: As selected by Mason from Supplier’s full range (sample to be provided by Contractor).

- B. Suppliers: Subject to compliance with requirements, provide products by one of the following:
1. Texas Architectural Aggregate, Inc.
 2. Fister Quarries Group Inc.
 3. Or equivalent, as accepted by Mason.
- C. Use only a single supply source for the entire quantity required.
- D. Screening shall be clean, hard, durable particles of fragments of select granite. Fines shall be evenly mixed throughout the aggregate. When produced from gravel, 50 percent, by weight, of the material retained on a No.4 sieve shall have one fractured face.
- E. The portion retained on the No.4 sieve shall have a maximum percentage of wear of 50 at 500 revolutions as determined by AASHTO T96-77. The portion passing a No. 4 sieve shall have a maximum liquid limit of 25 and a maximum plasticity index of 7, as determined by AASHTO T89-81, respectively.
- F. Grading requirements:

Percentage of Weight Passing a Square Mesh Sieve
AASHTO T11-82 and T27-82

<u>Sieve Designations</u>	<u>Passing Percent</u>	<u>Sieve Designation</u>	<u>Passing Percent</u>
No. 4	95 – 100%	No. 50	25 – 35%
No. 8	75 - 90%	No. 100	20 – 25%
No. 16	55 - 65%	No. 200	10 – 15%
No. 30	40 - 50%		

1. Before topsoiling, establish needed erosion and sediment control practices such as diversions, grade stabilization structures, berms, dikes, level spreaders, waterways, sediment basins, etc. These practices must be maintained during topsoiling.
2. Grading: Previously established grades on the areas to be topsoiled shall be maintained according to the approved plan.

2.14 LANDSCAPE EDGES

- A. Steel Edging: Standard commercial-steel edging, rolled edge, fabricated in sections of standard lengths, with loops stamped from or welded to face of sections to receive stakes.
1. Edging Size: 1/4 inch (6.4 mm) wide by 5 inches (125 mm) deep
 2. Stakes: Tapered steel, a minimum of 15 inches (380 mm) long.
 3. Accessories: Standard tapered ends, corners, and splicers.
 4. Finish: Zinc coated
 5. Manufacturers: Subject to compliance with requirements, provide products by one of the following:
 - a. Border Concepts, Inc.
 - b. Collier Metal Specialties, Inc.
 - c. Russell, J. D. Company (The).

- d. Ryerson Tull, Inc.
- e. Or equivalent, as accepted by Mason.

2.15 EROSION CONTROL FABRIC

- A. Temporary Turf Reinforcement Mat (TRM)
 - 1. North American Green DS75 or approved equivalent, FHWA Type 1.C, ultra-short term single-net erosion control blanket
 - a. Longevity: 45-days
 - b. Matrix: 100% straw fiber (0.50-lb/yd²)
 - c. Netting: top side only, lightweight photodegradable with photo-accelerators, minimum netting weight 1.50-lb/1000-ft²
 - d. Thread: degradable
 - 2. North American Green DS150 or approved equivalent, FHWA Type 1.D, ultra-short term double-net erosion control blanket
 - a. Longevity: 2-months
 - b. Matrix: 100% straw fiber (0.50-lb/yd²)
 - c. Netting: both sides, lightweight photodegradable with photo-accelerators, minimum netting weight 1.50-lb/1000-ft².
 - d. Thread: degradable.
 - 3. North American Green S75 or approved equivalent, FHWA Type 2.C, short-term singlenet erosion control blanket and open weave textile.
 - a. Longevity: 12-months
 - b. Matrix: 100% straw fiber (0.50-lb/yd²)
 - c. Netting: top side only, lightweight photodegradable, minimum netting weight 1.50-lb/1000-ft²
 - d. Thread: degradable
 - 4. North American Green S150, S150BN, or approved equivalent, FHWA Type 2.D, shortterm double-net erosion control blanket.
 - a. Longevity: 12-months
 - b. Matrix: 100% straw fiber (0.50-lb/yd²)
 - c. Netting:
 - 1. S150: both sides, lightweight minimum netting weight 1.50-lb/1000-ft²
 - 2. S150BN: top – leno woven 100% biodegradable organic jute fiber, minimum netting weight 9.30-lb/1000-ft², bottom - 100% biodegradable organic jute fiber, minimum netting weight 7.70-lb/1000-ft².
 - d. Thread:
 - 1. S150: degradable
 - 2. S150BN: biodegradable
 - 5. North American Green SC150, SC150BN, or approved equivalent, FHWA Type 3.B, extended term double-net erosion control blanket and open weave textile
 - a. Longevity: 24-months (SC150), 18-months (SC150BN)

- b. Matrix: 70% straw fiber (0.35-lb/yd²), 30% coconut fiber (0.15-lb/yd²)
 - c. Netting:
 1. SC150: top side heavyweight photodegradable with UV additives, 3.00-lb/1000-ft², bottom side – lightweight photodegradable, minimum netting weight 1.50-lb/1000-yd
 2. SC150BN: top – leno woven 100% biodegradable organic jute fiber, minimum netting weight 9.30-lb/1000-ft², bottom - 100% biodegradable organic jute fiber, minimum netting weight 7.70-lb/1000-ft².
 - d. Thread:
 1. S150: degradable
 2. S150BN: biodegradable
6. North American Green C125, C125BN, or approved equivalent, FHWA Type 4, long term double-net erosion control blanket or open weave textile
- a. Longevity: 36-months (C125), 24-months (C125BN)
 - b. Matrix: 100% coconut fiber, 0.50-lb/yd².
 - c. Netting:
 1. C125: both sides, heavyweight UV stabilized approximate netting weight 3.00-lb/1000-ft².
 2. C125BN: top – leno woven 100% biodegradable organic jute fiber, minimum netting weight 9.30-lb/1000-ft², bottom - 100% biodegradable organic jute fiber, minimum netting weight 7.70-lb/1000-ft².
 - d. Thread:
 1. C125: 100% black polypropylene
 2. C125BN: Biodegradable
- B. Semi-Permanent
1. Biodegradable woven fabric.
 - a. Requirements:
 - b. Material: 100% spun coir or jute functional for at least 2 growing seasons.
 - c. Open area: 50% to 65% suitable for seedings after installation.
 - d. Wide width tensile (wet): 38 lbs.
 - e. Elongation at failure (wet): 47%.
 - f. Water Flow Velocity: .8 ft. /sec.
 - g. Application: specifically recommended for use as erosion control on slopes up to 1 in 2 until planting is established.
 2. Manufacturer: Subject to compliance with requirements, provide products by one of the following:
 - a. North American Green
 - b. Belton Industries Inc. – “Geocoir DeKoWe 400” Coir mat.
 - c. Belton Industries Inc. – “Geocoir DeKoWe 700” Coir mat.
 - d. RoLanka International Inc. – “Jute mat.”
 - e. Or equivalent, as accepted by Mason.
- C. Permanent Turf Reinforcement Mat (TRM)

1. North American Green P300, SC250, C350, P550, or approved equivalent, FHWA Type 5.A/5.B, permanent turf reinforcement mat
 - a. Longevity: NA
 - b. Matrix:
 1. P300: 100% UV stable polypropylene fiber, 0.70-lb/yd²
 2. SC250: 70% straw fiber (0.35-lb/yd²), 30% coconut fiber (0.15-lb/yd²)
 3. C350: 100% coconut fiber, 0.50-lb/yd²
 4. P550: 100% UV stable polypropylene fiber, 0.50-lb/yd²
 - c. Netting:
 1. P300: top side – heavyweight UV stabilized, netting weight 5.00-lb/1000-ft², bottom side - heavyweight UV stabilized, netting weight 3.00-lb/1000-ft²
 2. SC250: top and bottom – heavy duty UV stabilized polypropylene netting weight 5.00-lb/1000-ft², mid – corrugated ultra-heavy duty UV stabilized polypropylene, netting weight 24-lb/1000-ft²
 3. C350: top and bottom – super heavy duty UV stabilized polypropylene netting weight 8.00-lb/1000-ft², mid – corrugated ultra-heavy duty UV stabilized polypropylene, netting weight 24-lb/1000-ft².
 4. P550: top and bottom – ultra heavy duty UV stabilized polypropylene netting weight 24-lb/1000-ft², mid – corrugated ultra-heavy duty UV stabilized polypropylene, netting weight 24-lb/1000-ft².
 - d. Thread:
 1. P300: 100% Black Polypropylene
 2. SC250, C350, P550: UV Stabilized polypropylene

PART 3 – EXECUTION

3.1 EXAMINATION

- A. Existing conditions: Before starting work, examine related work and surfaces. Verify that Earthwork rough grading has resulted in the conforming subgrades with in specified tolerances.
- B. Weather Limitations: Proceed with soil works when existing and forecasted weather conditions permit.
- C. Moisture Content: Do not work when moisture content is so great that excessive compaction will occur, nor when it is so dry that dust will form in air or clods will not break readily. Water, if necessary, to bring soil to moisture content suitable for tilling and spreading. Do not spread if subgrade is frozen, muddy, at optimum moisture content or excessively wet.
- D. The topsoil shall be uniformly distributed to a minimum compacted depth of 2 inches on 3:1 or steeper slopes and 4 inches on flatter slopes. (See Table 3.30-A to determine volume of topsoil required for application to various depths). Any irregularities in the

surface, resulting from topsoiling or other operations, shall be corrected in order to prevent the formation of depressions or water pockets.

- E. It is necessary to compact the topsoil enough to ensure good contact with the underlying soil and to obtain a level seedbed for the establishment of high maintenance turf. However, undue compaction is to be avoided as it increases runoff velocity and volume, and deters seed germination. Special consideration should be given to the types of equipment used to place topsoil in areas to receive fine turf. Avoid unnecessary compaction by heavy machinery whenever possible. In areas which are not going to be mowed, the surface should be left rough in accordance with SURF ACE ROUGHENING (Std. & Spec. 3.29).
- F. Fine grading shall conform with approved grading plan and positively drain in all directions as indicated on the approved plan.

3.2 PREPARTION

- A. Protect utilities, structures, foundations, sidewalks, pavements, other facilities, lawns and plants from damage caused by operations or as a result of operations.
 - 1. Utilities: After locating and marking, verify the status of utilities. Protect or temporarily divert existing utilities to remain active. Rectify immediately any obstruction or damage to utilities to remain active and provide and pay for temporary utilities where repairs are carried out to the satisfaction of the utility owner.
 - 2. Property: Do not interfere with or damage property that is to remain on or adjacent to the site, including adjoining property to the site, and trees. Rectify immediately any interference or damage to such property. Protect finishes from staining.
 - 3. Trees: If the trees are damaged or placed under unnecessary and avoidable stress by the Contractor, the Mason Representative shall deduct damages from the Contractor's progress claim. In addition, the Contractor shall provide vegetation of like species with cumulative equivalent tree canopy coverage.
 - 4. Irrigation: Install a temporary diversion main, control cable and valves to isolate contract area and to maintain service to areas outside of the contract area.
- B. Provide temporary erosion-control and slope stability measures to prevent erosion, displacement of soils, and discharge of soil-bearing water runoff or airborne dust to adjacent properties and completed work. Provide all stabilization and control measures needed to establish plantings on planted slopes and soils.

3.3 LAYOUT

- A. Lines and Elevations: The visual appearance and acceptable tolerances of the design is critically dependent upon the layout of the works. Include all costs and provide all instruments necessary to set out the works accurately. Establish lines and elevation markers located and laid out by survey instrumentation for all finish grades. Provide

additional grade stakes and string lines as required to achieve grades and to enable field observations by the Mason. Reinstall markers/stakes as required throughout the works.

- B. Verify: Include all costs and provide all calculations necessary to verify the subgrade, substrate and/or structural set-down elevations from the finish elevations minus thickness of overlying finishes. If any discrepancy is found notify Mason LD before final grading.
- C. Review: Mason LD shall review the field layout and retains the right to direct adjustments to the layout within 2 days. Include costs and allow time to adjust the layout.

3.4 GRADING FIELD ADJUSTMENTS

- A. Field Direction: Mason LD may direct field adjustments to the documented grades including but not limited to,
 - 1. fine grading for ridges, swales, edges, planar slopes,
 - 2. aesthetic shaping,
 - 3. transitioning to existing elements,
 - 4. Adjustments due to the tolerance of the survey.
- B. Include costs and allow time to adjust the fine grading assuming adjustments shall be cut to fill within the project site.

3.5 AMENDING SUBGRADE

- A. Weed control: Eradicate all non-sterile weeds. Ensure weeds are actively growing prior to spraying. Protect non-target species. Do not spray in temperatures over 90 degrees F (32 degrees C), windy conditions nor if rain is forecasted within 6 hours. Wear safety protection when mixing and spraying. Erect warning signs and exclude entry by other personnel. Apply without spray drift or over spray and in strict accordance with manufacturer's directions. Allow weeds to deteriorate approximately one-week prior to any necessary re-treatment. After retreated weeds have died, slash weeds and leave as mulch to be turned into soil. Continue isolated or spot control of any further invasion or germination throughout the course of the work.
- B. Testing: Take representative tests of each homogenous area of subgrade color and texture to be planted and raise the standard of the subgrade by the use of additives and/or aeration as determined by the subsoil tests and recommended by the Soils Report.
- C. Field exploration of the site shall be made to determine if there is sufficient surface soil of good quality to justify stripping. Topsoil shall be friable and loamy (loam, sandy loam, silt loam, sandy clay loam, and clay loam). It shall be free of debris, trash, stumps, rocks, roots, and noxious weeds, and shall give evidence of being able to support healthy vegetation. It shall contain no substance that is potentially toxic to plant growth.

- D. Topsoil operations should not be performed when the soil is wet or frozen. Stripping shall be confined to the immediate construction area. A 4-to 6-inch stripping depth is common, but depth may vary depending on the particular soil. All perimeter dikes, basins, and other sediment controls shall be in place prior to stripping.
- E. Shaping & Trimming: Grade, trim and shape rough grading subgrades from prior earthworks to a depth below finished surface levels as determined by the specified thickness of overlaying materials. Ensure shaping reflects the finish elevations plus or minus the thickness tolerances of the overlaying materials.
- F. Plowing/Ripping: Rip subgrade of planting areas and to a minimum thickness of 6 inches (150 mm). Remove or breakup all materials larger than 2 inches (50 mm) in any dimension, sticks, roots, rubbish, and other extraneous matter and legally dispose of them. All gravel and stone shall be removed from the topsoil prior to vegetation placement.
- G. Deep Plowing/Subsoiling: Ensure utilities are located and moisture content is correct. Space rippers/chisels to loosen 100% of surface on slopes less than 1in3 and 50% of surface on slopes steeper than 1in3 parallel to contours.
- H. Amending: Apply amendments in proportions and amounts recommended by the Soils Report over the loosened subgrade. Mix thoroughly to a depth determined by Soils Report.
- I. Existing Trees: Hand-cultivate less than 2 inches deep within the drip line of existing trees to remain. Cultivate immediately prior to placing the overlying Planting Soil.
- J. Protection: Protect prepared area from re-compaction and crust formation until spreading Planting Topsoil. Repeat ripping for any area re-compacted or eroded. Hydro-mulch with a sterile nurse crop and/or cover with jute mat if subgrade is to be exposed for more than 10 working days.

3.6 PLACING AND SPREADING PLANTING SOILS

- A. Only commence spreading after soils have been tested and shown to conform.
- B. Use equipment and methods that spread loads without over-compacting the Planting Soil profile. Do not use vibratory equipment.
- C. Spread Planting Soils in lifts not exceeding 6 inches to the depths and tolerances shown on the drawings but not less than required to meet finish grades after settlement/consolidation.
- D. Spread Planting Soils evenly throughout areas and rototill or disk-harrow the top of each lift before placing the next lift. Blend different soil types where they adjoin.

- E. On slopes steeper than 1 in 4, place and spread Planting Soils from the bottom up and apply jute matting to promote soil stability.
- F. If Planting Topsoil includes in field amendments rototill before planting.
- G. Apply water as required to induce settlement.
- H. When adequately dry, re-grade or re-screed smooth, adding additional Planting Topsoil as required to meet finished grades and elevations.
- I. Grading between required lines and grades to be smooth, uniform and planar. Slope finish grades to drain surface water away from buildings, and other structures. Slope finish grades to drain with uniform slope between points where elevations are given or between points and existing grades.
- J. Unless otherwise noted, grade intersections of planar slopes to crisp sharp intersections at high point ridges and low point troughs and swales. Do not round off such intersections.
- K. Fine rake until the surface is smooth, friable, and of a uniform fine texture and compaction having no lumps or stones over the specified solid materials size. Screed if necessary to achieve smooth slopes and sharp intersections of planes.
- L. Protect soil from further compaction. Where areas are compacted to more than 85% Proctor, rip to depth of soil, rototill and blade smooth. Restore planting beds if eroded or otherwise disturbed after finish grading and before planting.
- M. Hydroseed with a sterile nurse crop and/or cover with erosion control mat if Planting Topsoil is to be exposed for more than 10 working days.
- N. If possible leave Planting Topsoil fallow and encourage any weeds to germinate before eradicating them.
- O. Top-up Planting Soils if settlement and/or consolidation occur outside the specified tolerances anytime during the contract maintenance period.

3.7 TOLERANCES

- A. Comply with tolerances as follows:
 1. Elevation: Plus 1/2 inch (15 mm) or minus 1/2 inch (15 mm).
 2. Thickness: Plus 2 inches (50 mm) or minus 0 inch (0 mm).
 3. Surface: Gap below 10-foot- (3-m-) long straightedge not to exceed 1 inch (25 mm) in any direction (excluding intersections of planes at ridge & toe lines).

4. Slope: unless otherwise noted on the drawings not less than 1% fall.
5. Settlement: less than 1/4 inch (6 mm) against adjoining pavements, structures and drainage inlets.

3.8 FIELD QUALITY CONTROL

- A. Testing Agency: Engage a qualified independent testing agency to perform quality control testing.
- B. Sampling: Visually inspect soils on the surface and in core holes and take samples to reflect the maximum range of variability in each type of soil from each source.
 1. Composite sampling is only permitted if soil source has undergone mixing during execution.
 2. Take sample of size adequate provide soil for each test required.
- C. Test Type: For in field compliance testing the following definitions apply.
 1. Full Test – All specified characteristics.
 2. Part Test – pH and EC only.
- D. Test for specified characteristics of each soil type from each source at the following locations and frequencies:
 1. One Full Test for every soil type from each source.
 2. At least one Part Test for every 250 cubic yards (192 cubic meters), but in no case fewer than three tests.
- E. When testing agency reports that soils have not achieved specified requirements undertake a Full Test, rework and retest until specified characteristics are obtained.

3.9 PLACING LANDSCAPE SOIL REINFORCING

- A. Seek and comply with manufacturer's written installation guidelines on anchoring, pegging, stapling, joining and overlapping. Such guidelines shall be specific to the Project site and application.

3.10 PLACING EROSION CONTROL FABRIC

- A. Lay loosely on surface to ensure fabric/ground contact. Provide at least 12 inches (300mm) overlap at joints. If not detailed on drawings use dead stout stake to manufacturer's written recommendations.

3.11 PLACING INORGANIC MULCH

- A. Prior to application of mulch remove all grass, weeds, rubbish and other deleterious matter from surface. Mulch may be applied immediately after planting and irrigation piping.

- B. After blending, place on prepared Planting Subsoil, and rake smooth using a steel line rake to desired grade and cross section. Place in two equal thickness lifts to avoid segregation.
- C. Place to thickness of 4 inches (100mm). Do not place mulch against plant stems.
- D. Hand-tamp edges around benches, signposts, etc. Use a lawn roller, to obtain the final desired dense, smooth, uniform texture. Do not use wackers or vibratory rollers.
- E. Take care compacting adjacent to planting and irrigation systems.
- F. Rake and finish surface of mulch to be smooth, uniform, and solid. Dried, compacted material shall be firm all the way through with no “spongy” areas. Loose material shall not be present on the surface until after the first year of use. Tamp or roller marks shall not be present.
- G. Smooth out any significant irregularities prior to Substantial Completion. Smooth by rewetting /saturating rough areas thoroughly, and then rolling again.

3.12 INORGANIC MULCH TOLERANCES

- A. Comply with tolerances as follows:
 - 1. Elevation: 1/4 inch (6 mm).
 - 2. Thickness: Plus or minus 1/4 inch (6 mm).
 - 3. Surface: Gap below 10-foot- (3-m-) long straightedge not to exceed 1/4 inch (6 mm) in any direction.
 - 4. Slope: unless otherwise noted on the Drawings not less than 1% fall.
 - 5. Settlement: less than 1/4 inch (6 mm) against adjoining pavements, structures and drainage inlets.

3.13 EDGING INSTALLATION

- A. Steel Edging: Install steel edging where indicated according to manufacturer's written instructions. Anchor with steel stakes spaced approximately 30 inches (760 mm) apart, driven below top elevation of edging.
- B. Tolerance: Install edges to the following tolerances.
 - 1. Horizontal alignment plus or minus 1/2-inch (13-mm) over 10-foot- (3-m-) long straightedge.
 - 2. Vertical alignment plus or minus 1/2-inch (13-mm) over 10-foot- (3-m-) long straightedge.

3.14 CLEANUP AND PROTECTION

- A. Keep adjacent paving and construction clean and work area in an orderly condition.

APPENDIX I.2: TURF AND GRASSES

PART 1 – GENERAL

1.1 RELATED DOCUMENTS

- A. Drawings and general provisions of the Contract, including General and Supplementary Conditions and Division 01 Specification Sections, apply to this Section.
- B. George Mason University (Mason) Design Manual
- C. Virginia Erosion and Sediment Control Handbook (VESCH)

1.2 SUMMARY

- A. Section Includes:
 - 1. Seeding.
 - 2. Hydroseeding
 - 3. Sodding

1.3 DEFINITIONS

- A. Duff Layer: The surface layer of native topsoil that is composed of mostly decayed leaves, twigs, and detritus.
- B. Finish Grade: Elevation of finished surface of planting soil.
- C. Manufactured Topsoil: Soil produced off-site by homogeneously blending mineral soils or sand with stabilized organic soil amendments to produce topsoil or planting soil.
- D. Mason LD: Mason Land Development
- E. Pesticide: A substance or mixture intended for preventing, destroying, repelling or mitigating a pest. This includes insecticides, miticides, herbicides, fungicides, rodenticides, and molluscicides. It also includes substances or mixtures intended for use as a plant regulator, defoliant, or desiccant.

- F. Pests: Living organisms that occur where they are not desired or that cause damage to plants, animals or people. These include insects, mites, grubs, mollusks (snails and slugs), rodents (gophers, moles and mice), unwanted plants (weeds), fungi, bacteria, and viruses.
- G. Planting Soil: Standardized topsoil; existing, native surface topsoil; existing in-place surface soil; imported topsoil; or manufactured topsoil that is modified with soil amendments and perhaps fertilizer to produce a soil mixture best for plant growth.
- H. Subgrade: Surface or elevation of subsoil remaining after excavation is complete or top surface of a fill or backfill before planting soil is placed.
- I. Subsoil: All soil beneath the topsoil layer of the soil profile, and typified by the lack of organic matter and soil organisms.
- J. Surface Soil: Soil that is present at the top layer of the existing or pre-developed soil profile at the Project site. In undisturbed areas, the surface soil is typically topsoil, but in disturbed areas such as urban environments, the surface soil can be subsoil.

1.4 SUBMITTALS

- A. Product Data: For each type of product indicated.
 - A. Pesticides and Herbicides: Include product label and manufacturer's application instructions specific to this Project.
 - B. Certification of Grass Seed: From seed vendor for each grass-seed monostand or mixture stating the botanical and common name, percentage by weight of each species and variety, and percentage of purity, germination, and weed seed. Include the year of production and date of packaging.
 - 1. Certification of each seed mixture for turf grass sod. Include identification of source and name and telephone number of supplier.
- C. Qualification Data: For qualified landscape installer.
- D. Product Certificates: For soil amendments and fertilizers, from manufacturer.
- E. Material Test Reports: For all existing imported or manufactured topsoils.

- F. Maintenance Instructions: Recommended procedures to be established by Owner for maintenance of turf during calendar year. Submit before expiration of required initial maintenance periods.

1.5 QUALITY ASSURANCE

- A. Installer Qualifications: A qualified landscaper Installer whose work has resulted in successful turf establishment.
1. Installer's Field Supervision: Require Installer to maintain an experienced full-time supervisor on Project site when work is in progress.
 2. Maintenance Proximity: Not more than two hours normal travel time from Installer's place of business to Project site.
- B. Soil-Testing Laboratory Qualifications: An independent laboratory or university laboratory, recognized by the State Department of Agriculture, with the experience and capability to conduct the testing indicated and that specializes in types of tests to be performed.
- C. Soil Analysis: Furnish soil analysis and a written report by a qualified soil-testing laboratory stating percentages of organic matter; gradation of sand, silt and clay content; cation exchange capacity; sodium absorption ratio; deleterious material; pH; and mineral and plant-nutrient content of the soil.
1. Testing methods and written recommendations shall comply with USDA's Handbook No. 60.
 2. The soil-testing laboratory shall oversee soil sampling, with depth, location, and number of samples to be taken per instructions from the geotechnical engineer. A minimum of three representative samples shall be taken from varied locations for each soil to be used or amended for planting purposes.
 3. Report suitability of tested soil for turf growth.
 - a. Based on the test results, state recommendations for soil treatments and soil amendments to be incorporated. State recommendations in weight per 1000 sq. ft. (92.9 sq. m) or volume per cu. yd. (0.76 cu. m) for nitrogen, phosphorus, and potash nutrients and soil amendments to be added to produce satisfactory planting soil suitable for healthy, viable plants.
 - b. Report presence of problem salts, minerals, or heavy metals, including aluminum, arsenic, barium, cadmium, chromium, cobalt, lead, lithium, and vanadium. If such problem materials are present, provide additional recommendations or corrective action.

D. Soil Preparation (VESCH)

1. Prior to soil preparation, areas to be seeded, hydroseeded, and/or sodded shall be brought to final grade in accordance with the approved plan.
2. Soil tests will be executed to determine the exact requirements for lime and fertilizer. Soil tests may be conducted by an independent laboratory or university laboratory, recognized by the State Department of Agriculture.
3. Under difficult circumstances where it is not possible to obtain a soil test, the following soil amendments shall be made:
 - a. Pulverized agricultural limestone at 90 lbs. /1000 sq. ft. (2 tons/acre).
 - b. Fertilizer at 25 lbs./1000 sq. ft. (1000 lbs./acre) of 10-10-10 in fall, or 25 lbs./1000 sq. ft. of 5-10-10 in spring.
4. Note: Equivalent nutrients may be applied with other fertilizer formulations.
 - a. These amendments shall be spread evenly over the area to be seeded, hydroseeded, and/or sodded, and incorporated (if possible) into the top 3 to 6 inches of the soil by discing, harrowing or other acceptable means.
5. Any irregularities in the soil surface resulting from top-soiling or other operations shall be filled or leveled in order to prevent the formation of depressions or water pockets.
6. Areas to be topsoiled and topsoil used shall fulfill the requirements of TOPSOILING, Std. & Spec. 3.30. No sod shall be spread on soil which has been treated with soil sterilants or any other toxic herbicides until enough time has elapsed to permit dissipation of toxic materials.

E. Preinstallation Conference: Conduct conference at Project Site <location> with Mason LD.

1.6 DELIVERY, STORAGE, AND HANDLING

- A. Seed and Other Packaged Materials: Deliver packaged materials in original, unopened containers showing weight, certified analysis, name and address of manufacturer, and indication of conformance with state and federal laws, as applicable.
- B. Bulk Materials:
 1. Do not dump or store bulk materials near structures, utilities, walkways and pavements, or on existing turf areas or plants.

2. Provide erosion-control measures to prevent erosion or displacement of bulk materials, discharge of soil-bearing water runoff, and airborne dust reaching adjacent properties, water conveyance systems, or walkways.
3. Accompany each delivery of bulk fertilizers, lime, and soil amendments with appropriate certificates.

1.7 PROJECT CONDITIONS

- A. Planting Restrictions: Plant during one of the following periods. Coordinate planting periods with initial maintenance periods to provide required maintenance from date of Substantial Completion. Permanent seeding only during Spring – Fall, no seeding in winter, otherwise use sod.
 1. Spring Planting: March 1-March 14, or as approved by the Owner.
 2. Fall Planting: August 15-November 15, or as approved by the Owner.
- B. Weather Limitations: Proceed with planting only when existing and forecasted weather conditions permit planting to be performed when beneficial and optimum results may be obtained. Apply products during favorable weather conditions according to manufacturer's written instructions.

1.8 MAINTENANCE SERVICE

- A. Initial Turf Maintenance Service: Provide full maintenance by skilled employees of landscape Installer. Begin maintenance immediately after each area is planted and continue until acceptable turf is established but for not less than the following periods:
 1. Seeded Turf: 90 days from date of planting completion.
 2. When initial maintenance period has not elapsed before end of planting season, or if turf is not fully established, continue maintenance during next planting season.
 3. Sodded Turf: 30 days from date of planting completion.
 4. Plugged Turf: 30 days from date of planting completion.
 5. Sprigged Turf: 30 days from date of planting completion.

PART 2 – PRODUCTS

2.1 SEED

- A. Grass Seed: Fresh, clean, dry, new-crop seed complying with AOSA's "Journal of Seed Technology; Rules for Testing Seeds" for purity and germination tolerances.

- B. Seed Species: State-certified seed of grass species as follows: See Drawings.
- C. Seed Species: Seed of grass species as follows, with not less than 95 percent germination, not less than 85 percent pure seed, and not more than percent weed seed:
 - 1. Full Sun Mixture: Proportioned by weight as follows:
 - a. 50 percent Kentucky bluegrass.
 - b. 20 percent perennial ryegrass.
 - c. 15 percent chewings fescue.
 - d. 15 percent creeping red fescue.
 - 2. Shade Mixture: Proportioned by weight as follows:
 - a. 30 percent chewing fescue.
 - b. 15 percent creeping red fescue.
 - c. 30 percent Kentucky bluegrass.
 - d. 35 percent hard fescue.
- D. Grass Seed Mix: Proprietary seed mix as follows:
 - 1. Products: Subject to compliance with requirements and approval from Owner.

2.2 TURFGRASS SOD

- A. Turfgrass Sod: Certified, complying with “Specifications for Turfgrass Sod Materials” in TPI’s “Guideline Specifications to Turfgrass Sodding.” Furnish viable sod of uniform density, color and texture, strongly rooted, and capable of vigorous growth and development when planted. Sod used shall be state-certified. Certified turfgrass sod is grown from Certified seed, inspected and certified by the Virginia Crop Improvement Association (VCIA) or the certifying agency in other states. This ensures genetic purity, high quality, freedom from noxious weeds and excessive insect or disease problems. The sod must meet published state standards and bear an official blue "Certified Turf" label on the bill of lading.

**VIRGINIA CROP
IMPROVEMENT
ASSOCIATION**
BLACKSBURG, VIRGINIA



Certified Turf

The turf accompanying this invoice is represented by the producer to be a part of the lot that has been officially field inspected and has met the requirements for "Certified Turf" under the rules and regulations of the Virginia Crop Improvement Association.

No. 255

- B. Sod shall be machine cut at a uniform soil thickness of 3/4 inch (\pm 1/4 inch) at the time of cutting. This thickness shall exclude shoot growth and thatch.
- C. Pieces of sod shall be cut to the supplier's standard width and length, with a maximum allowable deviation in any dimension of 5%. Torn or uneven pads will not be acceptable.
- D. Standard size sections of sod shall be strong enough to support their own weight and retain their size and shape when suspended from a firm grasp on one end of the section.
- E. Turfgrass Species: Sod of grass species as follows, with not less than 95 percent germination, not less than 85 percent pure seed, and not more than 0.5 percent weed seed:
 - 1. 50 percent Kentucky bluegrass.
 - 2. 30 percent chewing fescue.
 - 3. 20 percent perennial ryegrass.
 - 4. 10 percent redtop

2.3 INORGANIC SOIL AMENDMENTS

- A. Lime: ASTM C 602, agricultural liming material containing a minimum of 80 percent calcium carbonate equivalent and as follows:
 - 1. Class: T, with a minimum of 99 percent passing through No.8 (2.36-mm) sieve and a minimum of 75 percent passing through No. 60 (0.25-mm) sieve.
 - 2. Class: 0, with a minimum of 95 percent passing through No.8 (2.36-mm) sieve and a minimum of 55 percent passing through No. 60 (0.25-mm) sieve.
 - 3. Provide lime in form of ground calcitic limestone.
- B. Sulfur: Granular, biodegradable, containing a minimum of 90 percent sulfur, and with a minimum of 99 percent passing through No.6 (3.35-mm) sieve and a maximum of 10 percent passing through No. 40 (0.425-mm) sieve.

- C. Iron Sulfate: Granulated ferrous sulfate containing a minimum of 20 percent iron and 10 percent sulfur.
- D. Aluminum Sulfate: Commercial grade, unadulterated.
- E. Perlite: Horticultural perlite, soil amendment grade.
- F. Agricultural Gypsum: Minimum 90 percent calcium sulfate, finely ground with 90 percent passing through No. 50 (0.30-mm) sieve.
- G. Sand: Clean, washed, natural or manufactured, and free of toxic materials.
- H. Diatomaceous Earth: Calcined, 90 percent silica, with approximately 140 percent water absorption capacity by weight.
- I. Zeolites: Mineral clinoptilolite with at least 60 percent water absorption by weight.

2.4 ORGANIC SOIL AMENDMENTS

- A. Compost: Well-composted, stable, and weed-free organic matter, pH range of 5.5 to 8; moisture content 35 to 55 percent by weight; 100 percent passing through 1/2-inch (12.5-mm) sieve; soluble salt content of 5 decisiemens/m; not exceeding 0.5 percent inert contaminants and free of substances toxic to plantings; and as follows:
 - 1. Organic Matter Content: 50 to 60 percent of dry weight.
 - 2. Feedstock: Agricultural, food, or industrial residuals; bio-solids; yard trimmings; or source separated or compostable mixed solid waste.
- B. Sphagnum Peat: Partially decomposed sphagnum peat moss, finely divided or of granular texture, with a pH range of 3.4 to 4.8.
- C. Muck Peat: Partially decomposed moss peat, native peat, or reed-sedge peat, finely divided or of granular texture, with a pH range of 6 to 7.5, and having a water-absorbing capacity of 1100 to 2000 percent
- D. Wood Derivatives: Decomposed, nitrogen-treated sawdust, ground bark, or wood waste; of uniform texture and free of chips, stones, sticks, soil, or toxic materials.
 - 1. In lieu of decomposed wood derivatives, mix partially decomposed wood derivatives with ammonium nitrate at a minimum rate of 0.15 lb/cu. ft. (2.4 kg/cu. m) of loose sawdust or ground bark, or with ammonium sulfate at a minimum rate of 0.25 lb/cu. ft. (4 kg/cu. m) of loose sawdust or ground bark.

- E. Manure: Well-rotted, un leached, stable or cattle manure containing not more than 25 percent by volume of straw, sawdust, or other bedding materials; free of toxic substances, stones, sticks, soil, weed seed, and material harmful to plant growth.

2.5 FERTILIZERS

- A. Fertilizers to be used on site shall abide by the approved Nutrient Management Plan for the university.

2.6 PLANTING SOILS

- A. Planting Soil: ASTM D 5268 topsoil, with pH range of 5.5 to 7, a minimum of 6 percent organic material content; free of stones 1 inch (25 mm) or larger in any dimension and other extraneous materials harmful to plant growth. Mix ASTM D 5268 topsoil in accordance with the VESCH to produce planting soil.
- B. Planting Soil: Existing, native surface topsoil formed under natural conditions with the duff layer retained during excavation process and stockpiled on-site. Verify suitability of native surface topsoil to produce viable planting soil. Clean soil of roots, plants, sod, stones, clay lumps, and other extraneous materials harmful to plant growth.
 - 1. Supplement with accepted planting soil when quantities are insufficient.
 - 2. Mix existing, native surface topsoil in accordance with the VESCH to produce planting soil.
- C. Planting Soil: Existing, in-place surface soil. Verify suitability of existing surface soil to produce viable planting soil. Remove stones, roots, plants, sod, clods, clay lumps, pockets of coarse sand, concrete slurry, concrete layers or chunks, cement, plaster, building debris, and other extraneous materials harmful to plant growth. Mix surface soil in accordance with the VESCH to produce planting soil.
- D. Planting Soil: Imported topsoil or manufactured topsoil from off-site sources. Obtain topsoil displaced from naturally well-drained construction or mining sites where topsoil occurs at least 4 inches (100 mm) deep; do not obtain from bogs or marshes.
 - 1. Additional Properties of Imported Topsoil or Manufactured Topsoil: Screened and free of stones 1 inch (25 mm) or larger in any dimension; free of roots, plants, sod, clods, clay lumps, pockets of coarse sand, paint, paint washout, concrete slurry, concrete layers or chunks, cement, plaster, building debris, oils, gasoline, diesel fuel, paint thinner, turpentine, tar, roofing compound, acid, and other extraneous materials harmful to plant growth; free of obnoxious weeds and invasive plants including quackgrass, Johnsongrass, poison ivy, nutsedge, nimblewill, Canada thistle, bindweed, bentgrass, wild garlic, ground ivy, perennial sorrel, and brome grass; not infested with nematodes, grubs, other pests, pest eggs, or other undesirable organisms

- and disease-causing plant pathogens; friable and with sufficient structure to give good tilth and aeration. Continuous, airfilled, pore-space content on a volume/volume basis shall be at least 15 percent when moisture is present at field capacity. Soil shall have a field capacity of at least 15 percent on a dry weight basis.
2. Mix imported topsoil or manufactured topsoil in accordance with the VESCH to produce planting soil.
- E. Lightweight On-Structure Planting Soil: Mix produced by modifying planting soil as follows:
1. Planting Soil: One part(s), except replace half of sand content with perlite.
 2. Additional Perlite: One part.
 3. Additional Sphagnum or Muck Peat: One part.
 4. Additional Lime: Ground calcitic limestone applied at the rate of 3 lb per cu. yd. (1.36 kg per cu. m).

2.7 MULCHES

- A. Straw Mulch: Provide air-dry, clean, mildew-and seed-free, salt hay or threshed straw of wheat, rye, oats, or barley.
- B. Sphagnum Peat Mulch: Partially decomposed sphagnum peat moss, finely divided or of granular texture, and with a pH range of 3.4 to 4.8.
- C. Muck Peat Mulch: Partially decomposed moss peat, native peat, or reed-sedge peat, finely divided or of granular texture, with a pH range of 6 to 7.5, and having a water-absorbing capacity of 1100 to 2000 percent.
- D. Compost Mulch: Well-composted, stable, and weed-free organic matter, pH range of 5.5 to 8; moisture content 35 to 55 percent by weight; 100 percent passing through I-inch (25-mm) sieve; soluble salt content of 2 to 5 decisiemens/m; not exceeding 0.5 percent inert contaminants and free of substances toxic to plantings; and as follows:
 1. Organic Matter Content: 50 to 60 percent of dry weight.
 2. Feedstock: Agricultural, food, or industrial residuals; bio-solids; yard trimmings; or source separated or compostable mixed solid waste.
- E. Fiber Mulch: Biodegradable, dyed-wood, cellulose-fiber mulch; nontoxic and free of plant-growth or germination inhibitors; with a maximum moisture content of 15 percent and a pH range of 4.5 to 6.5.

- F. Nonasphaltic Tackifier: Colloidal tackifier recommended by fiber-mulch manufacturer for slurry application; nontoxic and free of plant-growth or germination inhibitors.
- G. Asphalt Emulsion: ASTM D 977, Grade SS-I; nontoxic and free of plant-growth or germination inhibitors.

2.8 PESTICIDES

- A. Pesticides to be used on site shall abide by the approved Nutrient Management Plan for the university.

PART 3 – EXECUTION

3.1 EXAMINATION

- A. Examine areas to be planted for compliance with requirements and other conditions affecting performance.
 - 1. Verify that no foreign or deleterious material or liquid such as paint, paint washout, concrete slurry, concrete layers or chunks, cement, plaster, oils, gasoline, diesel fuel, paint thinner, turpentine, tar, roofing compound, or acid has been deposited in soil within a planting area.
 - 2. Do not mix or place soils and soil amendments in frozen, wet, or muddy conditions.
 - 3. Suspend soil spreading, grading, and tilling operations during periods of excessive soil moisture until the moisture content reaches acceptable levels to attain the required results.
 - 4. Uniformly moisten excessively dry soil that is not workable and which is too dusty.
- B. Proceed with installation only after unsatisfactory conditions have been corrected.
- C. If contamination by foreign or deleterious material or liquid is present in soil within a planting area, remove the soil and contamination as directed by Owner and replace with new planting soil.

3.2 PREPARATION

- A. Protect structures, utilities, sidewalks, pavements, and other facilities, trees, shrubs, and plantings from damage caused by planting operations.
 - 1. Protect adjacent and adjoining areas from hydroseeding and hydromulching overspray.

2. Protect grade stakes set by others until directed to remove them.
- B. Install erosion-control measures to prevent erosion or displacement of soils and discharge of soil-bearing water runoff or airborne dust to adjacent properties and walkways.

3.3 TURF AREA PREPARATION

- A. Limit turf subgrade preparation to areas to be planted.
- B. Newly Graded Subgrades: Loosen subgrade to a minimum depth of 4 inches (100 mm). Remove stones larger than 1 inch (25 mm) in any dimension and sticks, roots, rubbish, and other extraneous matter and legally dispose of them off Owner's property.
1. Apply superphosphate fertilizer directly to subgrade before loosening.
 2. Spread topsoil, apply soil amendments and fertilizer on surface as specified, and thoroughly blend planting soil.
 - a. Delay mixing fertilizer with planting soil if planting will not proceed within a few days.
 - b. Mix lime with dry soil before mixing fertilizer.
 3. Spread planting soil to a depth of 8 inches (200 mm) but not less than required to meet finish grades after light rolling and natural settlement. Do not spread if planting soil or subgrade is frozen, muddy, or excessively wet.
 - a. Spread approximately 1/2 the thickness of planting soil over loosened subgrade. Mix thoroughly into top 4 inches (100 mm) of subgrade. Spread remainder of planting soil.
 - b. Reduce elevation of planting soil to allow for soil thickness of sod.
- C. Unchanged Subgrades: If turf is to be planted in areas unaltered or undisturbed by excavating, grading, or surface-soil stripping operations, prepare surface soil as follows:
1. Remove existing grass, vegetation, and turf. Do not mix into surface soil.
 2. Loosen surface soil to a depth of at least 4 inches (100 mm). Apply soil amendments and fertilizers according to planting soil mix proportions and mix thoroughly into top 4 inches (100 mm) of soil. Till soil to a homogeneous mixture of fine texture.
 - a. Apply superphosphate fertilizer directly to surface soil before loosening.

3. Remove stones larger than 1 inch (25 mm) in any dimension and sticks, roots, trash, and other extraneous matter.
 4. Legally dispose of waste material, including grass, vegetation, and turf, off Owner's property.
- D. Finish Grading: Grade planting areas to a smooth, uniform surface plane with loose, uniformly fine texture. Grade to within plus or minus 1/2 inch (13 mm) of finish elevation. Roll and rake, remove ridges, and fill depressions to meet finish grades. Limit finish grading to areas that can be planted in the immediate future.
- E. Moisten prepared area before planting if soil is dry. Water thoroughly and allow surface to dry before planting. Do not create muddy soil.
- F. Before planting, obtain Owner's acceptance of finish grading; restore planting areas if eroded or otherwise disturbed after finish grading.

3.4 SEEDING

- A. Sow seed with spreader or seeding machine. Do not broadcast or drop seed when wind velocity exceeds 5 mph (8 km/h). Evenly distribute seed by sowing equal quantities in two directions at right angles to each other.
1. Do not use wet seed or seed that is moldy or otherwise damaged.
 2. Do not seed against existing trees. Limit extent of seed to outside edge of planting saucer.
- B. Sow seed at a total rate per VESCH.
- C. Rake seed lightly into top 1/8 inch (3 mm) of soil, roll lightly, and water with fine spray.
- D. Protect seeded areas with slopes exceeding 1:4 with erosion-control blankets and 1:6 with erosion-control fiber mesh installed and stapled according to manufacturer's written instructions.
- E. Protect seeded areas with erosion-control mats where shown on Drawings; install and anchor according to manufacturer's written instructions.
- F. Protect seeded areas with slopes not exceeding 1:6 by spreading straw mulch. Spread uniformly at a minimum rate per VESCH to form a continuous blanket 1-1/2 inches (38mm) in loose thickness over seeded areas. Spread by hand, blower, or other suitable equipment.
1. Anchor straw mulch by crimping into soil with suitable mechanical equipment.

2. Bond straw mulch by spraying with asphalt emulsion at a rate of 10 to 13 gal./1000 sq. ft. (38 to 49 L/92.9 sq. m). Take precautions to prevent damage or staining of structures or other plantings adjacent to mulched areas. Immediately clean damaged or stained areas.
- G. Protect seeded areas from hot, dry weather or drying winds by applying compost mulch or planting soil within 24 hours after completing seeding operations. Soak areas, scatter mulch uniformly to a thickness of 3/16 inch (4.8 mm), and roll surface smooth.

3.5 HYDROSEEDING

- A. Hydroseeding: Mix specified seed, fertilizer, and fiber mulch in water, using equipment specifically designed for hydroseeded application. Continue mixing until uniformly blended into homogeneous slurry suitable for hydraulic application.
1. Mix slurry with nonasphaltic tackifier.
 2. Apply slurry uniformly to all areas to be seeded in a one-step process.
 3. Apply slurry at a rate so that mulch component is deposited at not less than 1500-lb/acre (15.6-kg/92.9 sq. m) dry weight, and seed component is deposited at not less than the specified seed-sowing rate.

3.6 SODDING

- A. Lay sod within 24 hours of harvesting [unless a suitable preservation method is accepted by Owner prior to delivery time]. Do not lay sod if dormant or if ground is frozen or muddy. Sod shall be harvested, delivered, and installed within a period of 36 hours.

1992

3.33

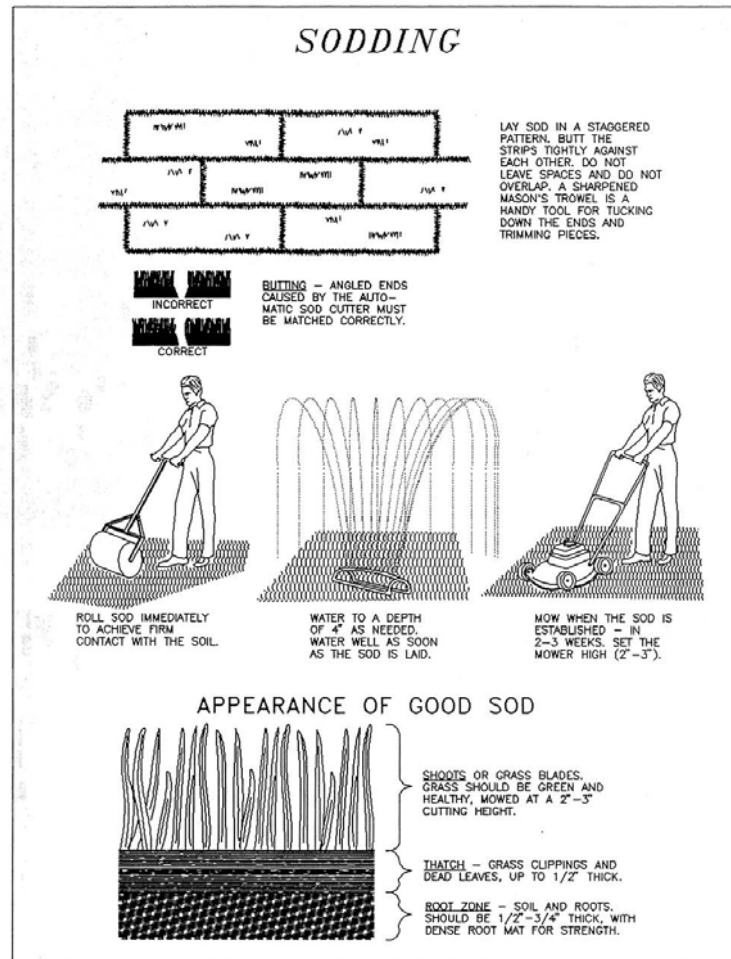

Source: Va. DSWC

Plate 3.33-1

- B. Install thin cut sand-based sod directly over sand filled clovers, sand filled no higher than the top of the clovers.
- C. Lay sod to form a solid mass with tightly fitted joints, moistened and rolled to create good contact for growth. Butt ends and sides of sod; do not stretch or overlap. Stagger sod strips or pads to offset joints in adjacent courses. Avoid damage to soil or sod during installation. Tamp and roll lightly to ensure contact with soil, eliminate air pockets, and form a smooth surface. Work sifted soil or fine sand into minor cracks between pieces of sod; remove excess to avoid smothering sod and adjacent grass.
 1. Lay sod across slopes exceeding 1:3, sod shall be laid with staggered joints and secured by stapling or other approved methods. Sod shall be installed with the length perpendicular to the slope (on the contour).

2. Anchor sod on slopes exceeding 1:6 with wood pegs [or steel staples] spaced as recommended by sod manufacturer but not less than two anchors per sod strip to prevent slippage.
- D. Saturate sod with fine water spray within two hours of planting. During first week after planting, water daily or more frequently as necessary to maintain moist soil to a minimum depth of 1-1/2 inches (38 mm) below sod.
- E. Sodded areas must be fertilized and kept moist during root establishment (minimum of 3 weeks).
- F. Sod should not be laid on soil surfaces that are frozen.
- G. During periods of high temperature, the soil shall be lightly irrigated immediately prior to laying the sod, to cool the soil and reduce root burning and dieback.
- H. As sodding of clearly defined areas is completed, sod shall be rolled or tamped to provide firm contact between roots and soil.
- I. After rolling, sod shall be irrigated to a depth sufficient that the underside of the sod pad and the soil 4 inches below the sod is thoroughly wet.
- J. Until such time a good root system becomes developed, in the absence of adequate rainfall, watering shall be performed as often as necessary to maintain moist soil to a depth of at least 4 inches.

The first mowing shall not be attempted until the sod is firmly rooted, usually 2-3 weeks. Not more than one third of the grass leaf shall be removed at any one cutting.

3.7 TURF MAINTENANCE

- A. General: Maintain and establish turf by watering, fertilizing, weeding, mowing, trimming, replanting, and performing other operations as required to establish healthy, viable turf. Roll, regrade, and replant bare or eroded areas and remulch to produce a uniformly smooth turf. Provide materials and installation the same as those used in the original installation.
 1. Fill in as necessary soil subsidence that may occur because of settling or other processes. Replace materials and turf damaged or lost in areas of subsidence.
 2. In areas where mulch has been disturbed by wind or maintenance operations, add new mulch and anchor as required to prevent displacement.
 3. Apply treatments as required to keep turf and soil free of pests and pathogens or disease. Use integrated pest management practices whenever possible to minimize the use of pesticides and reduce hazards.

- B. Watering: Install and maintain temporary piping, hoses, and turf-watering equipment to convey water from sources and to keep turf uniformly moist to a depth of 4 inches (100 mm).
1. During the 2 to 3 week establishment stage, sod shall be watered as necessary to maintain adequate moisture in the root zone and prevent dormancy of sod.
 2. No more than one third of the shoot (grass leaf) should be removed in any mowing. Grass height should be maintained between 2 and 3 inches unless otherwise specified.
 3. After the first growing season, established sod will require fertilization and may require lime. Follow soil test recommendations when possible, or apply maintenance levels as outlined in Table 3.33-B.
 4. Schedule watering to prevent wilting, puddling, erosion, and displacement of seed or mulch. Lay out temporary watering system to avoid walking over muddy or newly planted areas.
 5. Water turf with fine spray at a minimum rate of 1 inch (25 mm) per week unless rainfall precipitation is adequate.
 - a. Watering of turf shall be required for 1 month after installation.
- C. Mow turf as soon as top growth is tall enough to cut. Repeat mowing to maintain specified height without cutting more than one-third of grass height. Remove no more than one-third of grass-leaf growth in initial or subsequent mowings. Do not delay mowing until grass blades bend over and become matted. Do not mow when grass is wet. Schedule initial and subsequent mowings to maintain the following grass height:
1. Mow [bentgrass] to a height of 1/2 inch (13 mm) or less.
 2. Mow [bermudagrass] to a height of 1/2 to 1 inch (13 to 25 mm).
 3. Mow [carpetgrass] [centipede] [perennial ryegrass] [zoysiagrass] to a height of 1 to 2 inches (25 to 50 mm).
 4. Mow [Kentucky bluegrass] [buffalograss] [annual ryegrass] [chewings red fescue] to a height of 1-1/2 to 2 inches (38 to 50 mm).
 5. Mow [bahia] [turf-type tall fescue] [St. Augustine] to a height of 2 to 3 inches (50 to 75 mm).
- D. Turf Postfertilization: Apply [commercial fertilizer] [slow-release fertilizer] after initial mowing and when grass is dry.

3.8 SATISFACTORY TURF

- A. Turf installations shall meet the following criteria as determined by Owner:

1. Satisfactory Seeded Turf: At end of maintenance period, a healthy, uniform, close stand of grass has been established, free of weeds and surface irregularities, with coverage exceeding [90 percent over any 5 sq. ft. (0.46 sq. m) and bare spots not exceeding 3 by 3 inches (76 by 76 mm)].
 2. Satisfactory Sodded Turf: At end of maintenance period, a healthy, well-rooted, even-colored, viable turf has been established, free of weeds, open joints, bare areas, and surface irregularities.
 3. Satisfactory Plugged Turf: At end of maintenance period, the required number of plugs has been established as well-rooted, viable patches of grass, and areas between plugs are free of weeds and other undesirable vegetation.
 4. Satisfactory Sprigged Turf: At end of maintenance period, the required number of sprigs has been established as well-rooted, viable plants, and areas between sprigs are free of weeds and other undesirable vegetation.
- B. Use specified materials to reestablish turf that does not comply with requirements, and continue maintenance until turf is satisfactory.

3.9 CLEANUP AND PROTECTION

- A. Promptly remove soil and debris created by turf work from paved areas. Clean wheels of vehicles before leaving site to avoid tracking soil onto roads, walks, or other paved areas.
- B. Erect temporary fencing or barricades and warning signs as required to protect newly planted areas from traffic. Maintain fencing and barricades throughout initial maintenance period and remove after plantings are established.
- C. Remove non-degradable erosion-control measures after grass establishment period.
- D. Retain one of the following two subparagraphs to match grass installation method.
 1. Seeded areas must be protected from any traffic, other than for actual emergencies, for a period of 4 to 8 weeks, or until grass is mature enough to handle traffic.
 2. Sodded areas must be protected from any traffic, other than emergency vehicles, for a period of 3 to 4 weeks, or until root system has penetrated into subsoil.
- E. Remove nondegradable erosion-control measures after grass establishment period.
- F. Repair any damage to adjacent materials and surfaces resulting from installation of this work.

3.10 PERFORMANCE WARRANTY

-
- A. The turf or grasses shall be guaranteed for 1 year from the date of the Land Disturbance Permit Termination.
 - B. In the event that any turf does not meet the design intention, the contractor shall replace or repair all unsatisfactory turf.
 - a. All repair work shall be guaranteed for 1 year from the date of repair acceptance.

APPENDIX I.3: PIPE SEWER TV INSPECTION

PART 1 GENERAL

1.1 SCOPE:

- A. Work consists of furnishing all materials, labor, supervision, and equipment for the television inspection of new pipe sewers.
- B. Related Work Specified Elsewhere May Include But Is Not Limited To:
 - 1. Sewer Manholes.
 - 2. Pipe Sewer

1.2 QUALITY ASSURANCE

- A. Experience:
 - 1. Television inspection work shall be performed by a Contractor who is regularly engaged in work of the character required.
- B. Equipment:
 - 1. All equipment, devices and tools required for the contract shall be owned (or leased) and operated by the TV Inspection Contractor.

1.3 SUBMITTALS

- A. Before commencing work, the Contractor shall submit to MASON LD for approval:
 - 1. Specific documentation, information, and references that the TV Inspection Contractor and the on-site supervisor for the work have had successful experience in similar work under similar conditions.
 - 2. Detailed written descriptions, including pertinent supplemental drawings, literature, tables and other material, of equipment, methods, procedures and scheduling proposed for the work.
- B. A television inspection log shall be maintained during the television inspection work. This log shall be on a printed form and shall include the following:
 - 1. Job/work assignment number;
 - 2. Date of inspection;
 - 3. Location and identification of sewer section televised;
 - 4. Size and type of pipe;
 - 5. Length of sewer section televised;
 - 6. Locations of all service connections;
 - 7. Locations of all structural problems encountered such as cracked or broken pipe; offset or open joints; protruding service connections;
 - 8. Sags (including length and estimated depth);
 - 9. Incidence of root intrusion;

10. Areas where further cleaning is required;
 11. Recommendation of lining requirement.
 12. Locations of service connections as referenced by horizontal distance from identified manhole and circumferential position with respect to pipe axes.
- C. A summary report shall be submitted to the Engineer within ten days of the conclusion of TV inspection work including copies of all television inspection logs. The report shall be neatly bound in a protective cover.
1. DVD/CDs shall be submitted to the Engineer within ten days of the conclusion of fieldwork.

PART 2 EQUIPMENT

2.1 TELEVISION INSPECTION EQUIPMENT:

- A. Television inspection equipment shall include at least the following minimum items:
1. A color, sewer television camera, specifically designed for operation through a minimum of 2,000 feet of single conductor cable in sanitary and storm sewers.
 - a. Camera outside diameter no greater than 3-inches to allow for inspection in small size pipes. Camera operating temperature range of 0 to 50 degrees C.
 - b. Capable of providing 320 lines of horizontal resolution and 350 lines of vertical resolution.
 - c. Solid-state image pickup device containing in excess of 250,000 picture elements (pixels).
 - d. 525 scanning lines, 60 fields, 30 frames, interlaces 2:1 - NTSC Color Standard, with geometrical image distortion not exceeding two percent (picture transmission systems requiring use of R.F. suppressors and subject to local transmitter interference not acceptable).
 - e. Full, true color, sharp image video bandwidths with no sacrifice or visible streaking of low frequency response; also no visible streaking of the low frequency test bars when viewing a standard EIA Test Chart.
 - f. 1.OV (140 IRE units) composite camera video signal at the monitor after transmission through 2,000 feet of single conductor cable.
 - g. Equipped with an f/1.4 wide angle lens with optical viewing angle to 70 degrees, auto iris type to control the illumination range for an acceptable picture between 10 and 100,000 Lux, with manual override remotely controlled from the viewing station.
 - h. A minimum of 1,000 linear feet of cable to transmit picture from camera to recording and viewing unit.
 2. DVDs documenting all the television inspection with a ninety (90) minutes duration maximum, with "labels" indicating project address identification, date, along with voice description of sewer inspected during video recording.
 3. An on-board television viewing monitor consisting of high quality, industrial grade color unit providing in excess of 500 lines of resolution.

- a. High-resolution "trinitron" type picture tube or approved equivalent, measuring a minimum of 12 inches diagonally.
 - b. Include voltage compensation circuits to reduce picture distortion to less than one percent under voltage conditions varying from 105V to 120V.
 - c. Housed in a steel cabinet which acts as shield to minimize effects of local magnetic fields such as transformers, coils, wraps of cable, etc. (monitors having inadequate or no protection from local magnetic fields, thereby contributing to loss of color picture purity, not acceptable).
 - d. Equipped with a speaker to allow for audio playback from the DVD recording.
4. Lighting Equipment:
- a. The halogen lighting system or approved equivalent system shall be comprised of controlled-beam, reflector-sealed lamps with an automatic light compensator. The lighting system shall be capable of supplying variable light of high intensity.
- B. Camera Transport:
1. Portable, manual winches or motorized mechanical equipment of indirect drive type shall be provided complete with sufficient cable or rods to permit inspection of all sewer sections specified and capable of moving camera through the sewer pipe in either direction at a uniform, slow rate.
- C. Metering Device:
1. A remote reading, footage metering device(s) shall be provided such that camera location at ground level is visually displayed at all times on the television screen. Footage metering device shall be designed so that the distance recorder can be set at zero when camera is at entrance of pipe. Metering device shall have an accuracy of one percent \pm of actual distance between manholes. Marking of cable or similar means that require interpolation of depth of sewer, will not be permitted.
 2. A measuring target in front of the television camera shall be an exact measurement reference point, and the meter reading shall show the exact location of the reference point.
- D. Monitor Trailer:
1. A lighted trailer or other suitable shelter, complete with table and chairs, shall be provided for observation of the television monitor and record keeping. Trailer shall be large enough to accommodate at least three people at any time for the purpose of viewing the monitor while TV inspection is in progress.
- E. Accessories:
1. Accessory items shall include barricades, ladders, pulleys, safety equipment, etc.

PART 3 EXECUTION

3.1 TV INSPECTION:

A. General

1. The interior of new pipe sewers and the interior of existing pipe sewers and building sewers shall be visually inspected as directed by means of closed circuit television in the presence of the Engineer.
2. Inspection for all sewers shall be performed by moving the camera through the line along the axis of the pipe in either direction at a uniform slow rate by remote means, stopping at each joint or defect to allow adequate evaluation by the Engineer. For sewers 42-inches diameter and larger, camera movement shall be on a "hand held" basis.
3. The Engineer shall have access to the television monitor and all other operations at all times. The Contractor shall provide space for two MASON personnel at the same time in the trailer.
4. Picture quality and definition shall be as approved by the Engineer. If unsatisfactory, Contractor shall remove equipment, replace it with satisfactory equipment and repeat the inspection at no additional cost to MASON.
5. The Contractor shall make visual (with audio) tape recordings of each sewer inspection. Date, station (distance from manhole) and manhole identification shall be visually displayed on the videotape at all times.
6. All points of interest including all obstructions, broken pipe and other problems shall be indicated via audio during inspection.
7. Throughout the television inspection activities, MASON reserves the right to alter the speed at which the camera is moved through the sewer. Should the quality of the television picture fail to provide a clear view of the entire sewer, the Contractor shall make appropriate adjustments in his monitoring equipment or discontinue work until the Engineer agrees an acceptable picture has been obtained. Telephones or other suitable means of communication shall be set up between the two winches and the control monitor to coordinate the work.
8. Should the camera become stuck in the sewer, the Contractor will be responsible for its removal at no additional cost to MASON.

B. Safety:

1. Contractor is responsible for safety of personnel and the public during Contract period. The Contractor shall provide all devices, material and equipment necessary to assure the safety and health of personnel and the public.

PART 4 MEASURE AND PAYMENT

4.1 MEASURE

- A. Unit of measure will be the job with no direct measure taken, or per linear foot as provided in the Schedule of Prices and the Contract.

4.2 PAYMENT

- A. Payment for Pipe Sewer TV Inspection will be made at Contract price, as specified, which price and payment will include preparation of logs for all sections inspected, television equipment, and a complete DVD of each section, and all labor, materials, tools, equipment, and incidentals needed to perform television inspection as specified.

END OF SECTION