

**LIFTING INSERT DETAILS
FOR TOPS @ GRADE**

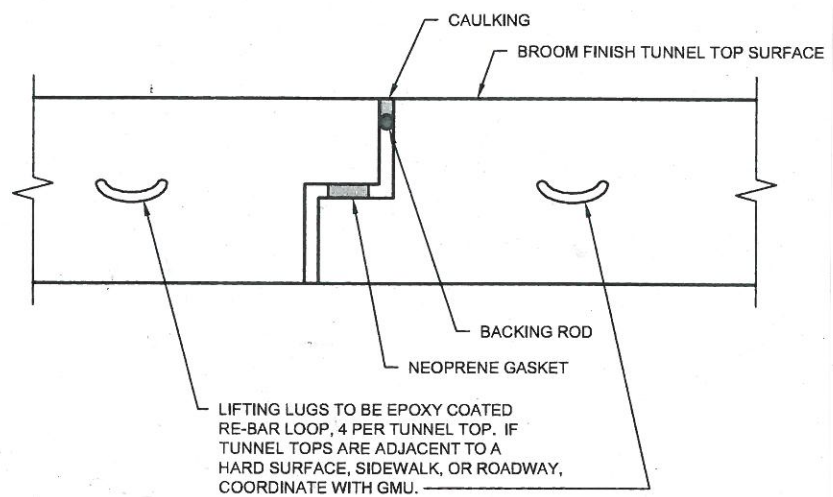

NOTES:

- 1) Construct tunnel and tops for H-20 loading.
- 2) Tops at grade unless precluded by abrupt grade changes, road crossing or other obstruction.
- 3) Tunnel tops not to exceed 4,500 pounds each.

NTS

Date: 6-3-2013



HTHW TUNNEL TOP DETAILS

Detail No: 4.1-2