

# George Mason University Design Information Manual



**Facilities Administration  
George Mason University  
4400 University Drive  
Fairfax, VA 22030-4444**

# Contents

|   |           |
|---|-----------|
| <b>PREFACE.....</b>                                     | <b>10</b> |
| <b>PART I - GENERAL ADMINISTRATIVE PROCEDURES .....</b> | <b>12</b> |
| PROJECT MANAGEMENT .....                                | 12        |
| INVOICING.....  | 12        |
| DRAWING STANDARDS .....                                 | 13        |
| <i>General</i> .....                                    | 13        |
| <i>Electronic Format</i> .....                          | 13        |
| <i>Bid Documents</i> .....                              | 13        |
| <i>Record Drawings</i> .....                            | 13        |
| <i>Size</i> .....                                       | 13        |
| <i>Lettering</i> .....                                  | 13        |
| <i>Title Sheet</i> .....                                | 13        |
| <i>Title Block</i> .....                                | 14        |
| <i>Drawing Arrangement and Number</i> .....             | 14        |
| <i>Unique Drawing Number</i> .....                      | 14        |
| Unique Drawing Number Assignment.....                   | 14        |
| Unique Drawing Number Samples .....                     | 15        |
| New Drawing Release Procedure .....                     | 15        |
| Drawing Revision Procedure .....                        | 15        |
| <i>Room Numbering</i> .....                             | 16        |
| <i>Foundation Elevations</i> .....                      | 17        |
| SPECIFICATION STANDARDS .....                           | 17        |
| <i>Coordination</i> .....                               | 17        |
| <i>Format</i> .....                                     | 17        |
| <i>Proof Reading</i> .....                              | 18        |
| <i>Prohibited Language</i> .....                        | 18        |
| <i>Codes and Code Compliance</i> .....                  | 19        |
| Barrier Free Design.....                                | 19        |
| <i>Materials and Equipment</i> .....                    | 19        |
| <i>Earthwork Specifications</i> .....                   | 20        |
| ESTIMATING STANDARDS .....                              | 20        |
| AREA AND VOLUME CALCULATIONS .....                      | 20        |
| SUBSURFACE INVESTIGATION .....                          | 20        |
| STORM DRAINAGE .....                                    | 20        |
| CONSTRUCTION CHANGE ORDER PROCEDURES .....              | 20        |
| PERMIT DOCUMENTATION .....                              | 21        |
| DEMOLITION MATERIALS .....                              | 22        |
| <b>PART II – FACILITIES AND SPACES .....</b>            | <b>22</b> |
| MASTER PLAN .....                                       | 22        |
| <i>Design Character</i> .....                           | 22        |

|   |           |
|---|-----------|
| <i>Planning</i> .....                                       | 22        |
| <i>Massing</i> .....  | 22        |
| <i>Roof Forms, Roof Lines and Silhouette</i> .....          | 23        |
| <i>Facades</i> .....  | 23        |
| <i>Architectural Details</i> .....                          | 23        |
| <i>Ornament</i> .....                                       | 24        |
| <i>Masonry</i> .....  | 24        |
| <i>Exterior Doors</i> .....                                 | 24        |
| <i>Color</i> .....  | 24        |
| <b>SPACE REQUIREMENTS</b> .....                             | <b>25</b> |
| <i>Administrative and Faculty Offices</i> .....             | 25        |
| <i>Custodial/Housekeeping Spaces</i> .....                  | 26        |
| <i>Recycling Spaces</i> .....                               | 27        |
| <i>Trash / Recycling Rooms for Student Housing</i> .....    | 27        |
| <i>Loading Docks</i> .....                                  | 27        |
| <i>Telecommunications Closet</i> .....                      | 28        |
| <i>Pay Telephones</i> .....                                 | 29        |
| <i>Classroom Specialties</i> .....                          | 29        |
| <i>Health-Safety Requirements</i> .....                     | 29        |
| Classroom Configuration.....                                | 29        |
| Laboratory, Shop, Studio, and Office Layouts .....          | 29        |
| Work Space.....   | 30        |
| Decontamination facilities .....                            | 30        |
| Hazardous Operations Areas.....                             | 30        |
| Egress.....   | 30        |
| Darkroom Ventilation .....                                  | 30        |
| Lounge Areas.....   | 31        |
| <b>SECURITY CONSCIOUS DESIGN</b> .....                      | <b>31</b> |
| <b>PART III, BID DOCUMENTS</b> .....                        | <b>32</b> |
| PROJECT MANUAL / SPECIFICATIONS ARRANGEMENT .....           | 32        |
| BIDDING PROCEDURES.....                                     | 32        |
| BID DOCUMENT DISTRIBUTION.....                              | 32        |
| ADDENDA .....   | 32        |
| GENERAL CONDITIONS .....                                    | 32        |
| <b>PART IV - CONSTRUCTION PRODUCTS AND ACTIVITIES</b> ..... | <b>33</b> |
| DIVISION 1: GENERAL REQUIREMENTS.....                       | 33        |
| 01300: <i>Administrative Requirements</i> .....             | 33        |
| 01320: Construction Progress Documentation .....            | 33        |
| Construction Photographs.....                               | 33        |
| Construction Schedule .....                                 | 33        |
| Final Site Survey.....                                      | 40        |
| 01500: <i>Temporary Facilities and Controls</i> .....       | 40        |
| 01510: Temporary Utilities.....                             | 40        |
| 01560: Temporary Barriers and Enclosures .....              | 40        |
| Construction Fence .....                                    | 40        |

|   |    |
|---|----|
| Tree and Plant Protection.....                          | 40 |
| 01700: <i>Execution Requirements</i> .....              | 41 |
| 01730: Execution .....                                  | 41 |
| Salvaged Materials and Equipment .....                  | 41 |
| 01780: Closeout Submittals .....                        | 41 |
| Operation and Maintenance Manuals (O&Ms).....           | 41 |
| Warranties.....   | 43 |
| Spare Parts and Maintenance Materials.....              | 44 |
| Final Site Survey.....                                  | 45 |
| 01800: <i>Facility Operation</i> .....                  | 45 |
| 01810: Commissioning .....                              | 45 |
| Commissioning Plan .....                                | 46 |
| 01820: Demonstration and Training .....                 | 49 |
| DIVISION 2: SITE CONSTRUCTION .....                     | 50 |
| 02050: <i>Basic Site Materials and Methods</i> .....    | 50 |
| 02080: Utility Materials.....                           | 50 |
| 02200: <i>Site Preparation</i> .....                    | 50 |
| 02220: Site Demolition.....                             | 50 |
| 02230: Site Clearing .....                              | 50 |
| 02300: <i>Earthwork</i> .....                           | 51 |
| 02315: Excavation and Fill .....                        | 51 |
| 02500: <i>Utility Services</i> .....                    | 51 |
| Pipeline Marker.....                                    | 52 |
| 02510: Water Distribution .....                         | 52 |
| 02530: Sanitary Sewerage.....                           | 54 |
| 02550: Piped Energy Distribution .....                  | 54 |
| 02580: Electrical and Communication Structures .....    | 54 |
| Telecommunications Service Entrance.....                | 55 |
| 02600: <i>Drainage and Containment</i> .....            | 56 |
| 02630: Storm Drainage.....                              | 56 |
| 02670: Paving Specialties.....                          | 56 |
| Parking Space Marking.....                              | 56 |
| 02700: <i>Bases, Pavements, and Appurtenances</i> ..... | 56 |
| 02740: Flexible Pavement.....                           | 56 |
| 02770: Curbs and Gutters .....                          | 57 |
| 02775: Sidewalks.....                                   | 57 |
| 02800: <i>Site Improvements and Amenities</i> .....     | 58 |
| 02810: Irrigation System.....                           | 58 |
| 02820: Fences and Gates .....                           | 58 |
| 02840: Walk, Road, and Parking Appurtenances .....      | 59 |
| 02870: Site Furnishings .....                           | 59 |
| Bicycle Racks.....                                      | 59 |
| Benches.....  | 59 |
| Waste Receptacles .....                                 | 59 |
| 02900: <i>Planting</i> .....                            | 60 |
| 02910: Plant Preparation.....                           | 60 |

|   |    |
|---|----|
| Subgrade .....  | 60 |
| Topsoil .....   | 60 |
| 02920: Lawns and Grasses.....   | 61 |
| Seed Mixtures .....   | 61 |
| Inspections .....   | 62 |
| 02930: Exterior Plants.....   | 62 |
| Warranty .....  | 62 |
| 02935: Plant Maintenance.....   | 63 |
| 02945: Planting Accessories.....  | 63 |
| Landscape Edging.....   | 63 |
| Planters.....   | 63 |
| DIVISION 3: CONCRETE.....   | 64 |
| 03300: <i>Cast-In-Place Concrete</i> .....  | 64 |
| 03310: <i>High Temperature Hot Water Tunnel see Part V – Standard Details, HTHW Tunnel Detail, Fairfax Campus , HTHW Tunnel Top Details , HTHW Manhole Detail</i> ..... | 65 |
| 03400: <i>Precast Concrete</i> .....  | 65 |
| 03480: Bollards.....  | 66 |
| DIVISION 4: MASONRY .....   | 66 |
| 04050: Basic Masonry Materials and Methods .....  | 66 |
| 04060: Masonry Mortar.....  | 66 |
| 04090: Masonry Accessories.....   | 66 |
| 04200: <i>Masonry Units</i> .....   | 67 |
| 04220: Concrete Masonry Units.....  | 67 |
| 04700: <i>Simulated Masonry</i> .....   | 67 |
| 04720: Cast Stone .....   | 67 |
| 04800: <i>Masonry Assemblies</i> .....  | 67 |
| Sample Panels.....  | 67 |
| 04900 <i>Masonry Restoration and Cleaning</i> .....   | 68 |
| DIVISION 5: METALS.....   | 68 |
| 05100: <i>Structural Metal Framing</i> .....  | 68 |
| 05300: <i>Metal Deck</i> .....  | 69 |
| 05400: <i>Cold-Formed Metal Framing</i> .....   | 69 |
| 05450: Metal Support .....  | 69 |
| 05500: <i>Metal Fabrications</i> .....  | 69 |
| 05510: Metal Stairs and Ladders .....   | 69 |
| 05520: Handrails and Railings.....  | 69 |
| DIVISION 6: WOOD AND PLASTICS.....  | 70 |
| 06050: Basic Wood and Plastic Materials and Methods .....   | 70 |
| 06060: Wood Materials.....  | 70 |
| 06070: Wood Treatment .....   | 70 |
| 06100: <i>Rough Carpentry</i> .....   | 70 |
| 06130: Heavy Timber Construction.....   | 70 |
| Timber Trusses.....   | 70 |
| 06200: <i>Finish Carpentry</i> .....  | 70 |
| 06400: <i>Architectural Woodwork</i> .....  | 70 |
| 06410: Custom Cabinets.....   | 71 |

|   |    |
|---|----|
| DIVISION 7: THERMAL AND MOISTURE PROTECTION.....                                | 71 |
| 07050: <i>Basic Thermal and Moisture Protection Materials and Methods</i> ..... | 71 |
| 07100: <i>Dampproofing and Waterproofing</i> .....                              | 71 |
| 07170: Bentonite Waterproofing.....   | 72 |
| 07190: Water Repellents.....  | 72 |
| 07200: <i>Thermal Protection</i> .....  | 72 |
| 07210: Building Insulation.....   | 72 |
| 07240: Exterior Insulation and Finish Systems (EIFS).....                       | 72 |
| 07300: <i>Shingles, Roof Tiles, and Roof Coverings</i> .....                    | 73 |
| 07310: Shingles.....  | 73 |
| 07400: <i>Roofing and Siding Panels</i> .....                                   | 73 |
| 07500: <i>Membrane Roofing</i> .....  | 73 |
| 07600: <i>Flashing and Sheet Metal</i> .....                                    | 74 |
| 07620: Sheet Metal Flashing and Trim.....                                       | 74 |
| 07700: <i>Roof Specialties and Accessories</i> .....                            | 74 |
| 07710: Manufactured Roof Specialties.....                                       | 74 |
| 07720: Roof Accessories.....  | 74 |
| 07800: <i>Fire and Smoke Protection</i> .....                                   | 74 |
| 07810: Applied Fireproofing.....  | 74 |
| 07900: <i>Joint Sealers</i> .....   | 74 |
| DIVISION 8: DOORS AND WINDOWS.....  | 75 |
| 08100: <i>Metal Doors and Frames</i> .....                                      | 75 |
| 08200: <i>Wood and Plastic Doors</i> .....                                      | 75 |
| 08210: Wood Doors.....  | 76 |
| 08300: <i>Specialty Doors</i> .....   | 76 |
| 08330: Coiling Doors and Grilles.....   | 76 |
| Fire Shutters.....  | 76 |
| 08400: <i>Entrances and Storefronts</i> .....                                   | 76 |
| 08460: Automatic Entrance Doors.....  | 77 |
| 08500: <i>Windows</i> .....   | 78 |
| 08600: <i>Skylights</i> .....   | 79 |
| 08700: <i>Hardware</i> .....  | 79 |
| Elevator and Fire Alarm Panel Keys.....   | 81 |
| 08710: Finish Hardware Master Specification.....                                | 81 |
| 08740: Electro-Mechanical Hardware.....   | 91 |
| Card Key Locking Hardware.....  | 91 |
| DIVISION 9: FINISHES.....   | 92 |
| 09050: <i>Basic Finish Materials and Methods</i> .....                          | 92 |
| 09300: <i>Tile</i> .....  | 93 |
| 09310: Ceramic Tile.....  | 93 |
| 09330: Quarry Tile.....   | 93 |
| 09500: <i>Ceilings</i> .....  | 93 |
| 09510: Acoustical Ceilings.....   | 93 |
| 09600: <i>Flooring</i> .....  | 94 |
| 09650: Resilient Flooring.....  | 94 |
| 09680: Carpet.....  | 94 |

|   |     |
|---|-----|
| 09900: <i>Paints and Coatings</i> .....                   | 95  |
| DIVISION 10: SPECIALTIES .....                            | 95  |
| 10100: <i>Visual Display Boards</i> .....                 | 95  |
| 10110: Chalkboards .....                                  | 95  |
| 10115: Markerboards.....                                  | 95  |
| 10120: Tackboard and Visual Aid Boards.....               | 95  |
| 10150: <i>Compartments and Cubicles</i> .....             | 96  |
| Toilet Partitions.....                                    | 96  |
| 10350: <i>Flagpoles</i> .....                             | 96  |
| 10400: <i>Identification Devices</i> .....                | 96  |
| 10430: Exterior Signage .....                             | 96  |
| 10440: Interior Signage.....                              | 96  |
| 10500: <i>Lockers</i> .....                               | 96  |
| 10520: Fire Protection Specialties .....                  | 96  |
| Fire Extinguishers, Cabinets, and Accessories .....       | 96  |
| 10800: <i>Toilet, Bath, and Laundry Accessories</i> ..... | 97  |
| 10810: Toilet Accessories.....                            | 97  |
| DIVISION 11: EQUIPMENT .....                              | 98  |
| 11400: <i>Food Service Equipment</i> .....                | 98  |
| 11600: <i>Laboratory Equipment</i> .....                  | 98  |
| Fume Hoods .....  | 98  |
| Eyewash units .....                                       | 102 |
| Safety Showers: .....                                     | 103 |
| DIVISION 12: FURNISHINGS.....                             | 104 |
| 12300: <i>Manufactured Casework</i> .....                 | 104 |
| 12350: Specialty Casework.....                            | 104 |
| Wood Laboratory Casework.....                             | 104 |
| 12400: <i>Furnishings and Accessories</i> .....           | 104 |
| 12480: Rugs and Mats .....                                | 104 |
| Entrance Mats .....                                       | 104 |
| 12490: Window Treatments.....                             | 104 |
| 12500: <i>Furniture</i> .....                             | 104 |
| 12560: Institutional Furniture .....                      | 105 |
| Laboratory Furniture.....                                 | 105 |
| 12600: <i>Multiple Seating</i> .....                      | 106 |
| 12610: Fixed Audience Seating.....                        | 106 |
| DIVISION 13: SPECIAL CONSTRUCTION.....                    | 107 |
| 13100: <i>Lightning Protection</i> .....                  | 107 |
| 13110: <i>Cathodic Protection</i> .....                   | 107 |
| 13120: <i>Pre-Engineered Structures</i> .....             | 107 |
| 13200: <i>Storage Tanks</i> .....                         | 107 |
| 13850: <i>Detection and Alarm</i> .....                   | 108 |
| Fire Alarm Systems.....                                   | 108 |
| 13900: <i>Fire Suppression</i> .....                      | 108 |
| DIVISION 14: CONVEYING SYSTEMS .....                      | 113 |
| 14200: <i>Elevators</i> .....                             | 113 |

|   |     |
|---|-----|
| 14400: Lifts .....  | 117 |
| 14420: Wheelchair Lifts .....                                     | 117 |
| DIVISION 15: MECHANICAL .....                                     | 118 |
| 15000: Mechanical General Requirements .....                      | 118 |
| 15050: Basic Mechanical Materials and Methods .....               | 119 |
| 15060: Hangars and Supports .....                                 | 119 |
| 15075: Mechanical Identification .....                            | 119 |
| 15080: Mechanical Insulation .....                                | 120 |
| 15100: Building Services Piping .....                             | 120 |
| 15105: Pipes and Tubes .....                                      | 121 |
| 15110: Valves .....   | 122 |
| 15120: Piping Specialties .....                                   | 125 |
| Sleeves .....   | 125 |
| Expansion Compensation .....                                      | 125 |
| Meters and Gages .....  | 125 |
| 15130: Pumps .....  | 125 |
| HVAC Pumps .....  | 126 |
| 15140: Domestic Water Piping .....                                | 126 |
| 15150: Sanitary Waste and Vent Piping .....                       | 126 |
| 15160: Storm Drainage Piping .....                                | 127 |
| 15180: Heating and Cooling Piping .....                           | 127 |
| Hydronic Piping .....   | 127 |
| Steam and Condensate Piping .....                                 | 128 |
| 15190: Fuel Piping .....  | 128 |
| 15300: Fire Suppression Piping .....                              | 129 |
| 15400: Plumbing Fixtures and Equipment .....                      | 129 |
| 15410: Plumbing Fixtures .....                                    | 129 |
| Water Closet .....  | 129 |
| Drinking Fountain .....   | 129 |
| Service Sink .....  | 129 |
| 15480: Domestic Water Heaters .....                               | 129 |
| 15500: Heat-Generation Equipment .....                            | 130 |
| 15510: Heating Boilers and Accessories .....                      | 130 |
| 15520: Feedwater Equipment .....                                  | 130 |
| 15540: Fuel-Fired Heaters .....                                   | 130 |
| 15550: Breechings, Chimneys, and Stacks .....                     | 130 |
| 15600: Refrigeration Equipment .....                              | 131 |
| 15620: Packaged Water Chillers .....                              | 131 |
| Reciprocating Water Chillers .....                                | 131 |
| Centrifugal Chillers – Water Cooled .....                         | 131 |
| 15640: Packaged Cooling Towers .....                              | 131 |
| 15670: Refrigerant Condensing Units .....                         | 132 |
| 15700: Heating, Ventilating, and Air Conditioning Equipment ..... | 132 |
| Rooftop Heating and Cooling Units .....                           | 132 |
| 15710: Heat Exchangers .....                                      | 133 |
| 15720: Air Handling Units .....                                   | 133 |



|   |            |
|---|------------|
| 15730: Unitary Air Conditioning Equipment .....             | 134        |
| Window Air Conditioners .....                               | 134        |
| 15740: Heat Pumps .....                                     | 134        |
| 15760: Terminal Heating and Cooling Units .....             | 134        |
| <i>15800: Air Distribution</i> .....                        | <i>134</i> |
| 15810: Ducts .....  | 134        |
| 15830: Fans .....   | 134        |
| 15860: Air Cleaning Devices .....                           | 135        |
| <i>15900: HVAC Instrumentation and Controls</i> .....       | <i>135</i> |
| 15910: Direct Digital Controls .....                        | 136        |
| Test Plan .....   | 136        |
| Testing and Adjusting During and After Installation .....   | 137        |
| Commissioning Tests .....                                   | 137        |
| Final Operational Test and Acceptance .....                 | 139        |
| Guarantee and Service .....                                 | 140        |
| 15950: Testing, Adjusting, and Balancing .....              | 140        |
| DIVISION 16: ELECTRICAL .....                               | 142        |
| <i>16000: General Requirements</i> .....                    | <i>142</i> |
| <i>16050: Basic Electrical Materials and Methods</i> .....  | <i>143</i> |
| 16060: Grounding and Bonding .....                          | 143        |
| <i>16100: Wiring Methods</i> .....                          | <i>144</i> |
| 16120: Conductors and Cables .....                          | 144        |
| 16130: Raceway and Boxes .....                              | 146        |
| 16140: Wiring Devices .....                                 | 149        |
| <i>16200: Electrical Power</i> .....                        | <i>149</i> |
| 16220: Motors and Generators .....                          | 150        |
| 16230: Generator Assemblies .....                           | 150        |
| Emergency Generators .....                                  | 150        |
| <i>16300: Transmission and Distribution</i> .....           | <i>150</i> |
| 16360: Unit Substations .....                               | 150        |
| <i>16400: Low-Voltage Distribution</i> .....                | <i>152</i> |
| 16410: Enclosed Switches and Circuit Breakers: .....        | 152        |
| 16440: Switchboards, Panelboards, and Control Centers ..... | 153        |
| <i>16500: Lighting</i> .....                                | <i>157</i> |
| 16530: Emergency Lighting .....                             | 161        |
| <i>16700: Communications</i> .....                          | <i>161</i> |
| <b>PART V - STANDARD DETAILS.....</b>                       | <b>163</b> |
| HTHW TUNNEL DETAIL, FAIRFAX CAMPUS .....                    | 163        |
| HTHW TUNNEL TOP DETAILS: .....                              | 164        |
| HTHW MANHOLE DETAIL .....                                   | 165        |
| HTHW MAIN, PREFERRED ANCHORAGE DETAILS .....                | 165        |
| BICYCLE RACKS .....   | 167        |
| OUTDOOR BENCHES, FAIRFAX AND PRINCE WILLIAM CAMPUSES .....  | 168        |
| OUTDOOR BENCHES, ARLINGTON CAMPUS .....                     | 169        |
| TRASH RECEPTACLES, ALL CAMPUSES .....                       | 170        |
| COLLAPSIBLE BOLLARDS, ALL CAMPUSES .....                    | 171        |

## PREFACE

---

This manual is a guideline for Architects and Engineers, as well as anyone who is commissioned to design, renovate and otherwise alter buildings and related facilities for George Mason University (GMU). The intent is to clarify GMU procedures and standards, to indicate preferences on certain materials used in construction of our facilities, to avoid past problems, and to answer some of the miscellaneous questions that arise on building projects. It supplements the requirements of the Owner-Architect Agreement and should be considered a fundamental part of the Program provided for each individual project. Whenever the term “Architect” is used, it shall apply equally to “Engineer.”

It is the University’s intent to maximize the design potential of each campus building project in terms of accommodating the programs to be served, fostering collegiality on the campus, and contributing to the public realm that defines the University campus as a unique place.

In order to achieve the programmatic goals of each project, the design must cost-effectively overlay the specific, user-generated objectives for the project with the University objectives of institutional identity, durability, longevity, flexibility, and adaptability.

This manual will be presented on the Internet at <http://www.gmu.edu/departments/facilities/physicalplant/GMUStdManual/GMUstds.htm> and is available in loose-leaf form in order to permit periodic updating. Flexibility is inherent and changes will be made when necessary. The Architect or Engineer is responsible for confirming use of the most current version of this manual. Pages have been dated for this purpose.

Architects and Engineers are responsible to produce the best life cycle cost building possible within constraints of budget, and GMU does not wish to handicap their creative efforts by insistence on blind adherence to requirements. Variations will be considered and approved if there is an advantage to the University to do so. **However, intended variations must be brought to the attention of the University for specific written approval. Otherwise, Architects and Engineers will be held responsible for any additional costs resulting from failure to comply with this manual.**

An attempt has been made to establish performance rather than specification standards. The manual is not intended to be a “master specification” and therefore most of the language in this manual will need modification before being included in the Project Specifications.

To achieve these goals, it is incumbent upon the project design team to invest in an understanding not only of immediate program goals but also of the history of planning and architecture on the campus, of the goals and objectives of the current campus master plan, and particularly of the immediate context (precinct and site) for the project.

The text of the manual is arranged in four Parts as indicated below.

### **Part I - General Administrative Procedures**

This section defines the administrative procedures that Architects and Engineers must follow in working with the University. This statement of procedures is intended to establish a smooth operating relationship throughout the entire planning and construction and commissioning process.

### **Part II - Facilities and Spaces**

This section defines master plan requirements and space requirements.

### **Part III - Bid Documents**

This section outlines the format which should be used in assembling the project manual.

### **Part IV - Construction Products and Activities**

This section discusses technical requirements of materials and methods of construction. It is arranged on the basis of the Construction Specifications Institute (CSI) 16-Division Specification Format to include all of the areas in which the University requires certain minimal standards in the selection of materials and quality of workmanship. When this manual is silent on a particular material, no standards have been developed by the University. In all cases, the Architect or Engineer is to use professional judgment, and, where such judgment indicates material or methods contrary to information found in this manual, the Architect or Engineer should discuss these areas with the Project Manager in charge of their project.

### **Part V – GMU Standard Details**

This section contains standard details. These details are typical standards established by the University and are included to assist Architects and Engineers in preparing Drawings that are acceptable and uniform for all projects.

# **PART I - GENERAL ADMINISTRATIVE PROCEDURES**

## ***Project Management***

1. The A/E will work primarily with the Project Manager from the Facilities Planning Office. All input and coordination shall be through the Project Manager. Input during design will be generated by the Facilities Planning Office, the Facilities Construction Office, and the Facilities Physical Plant Office.
2. At award of the construction contract, a Representative from the Facilities Construction Office will oversee the contractor's work and administer the construction contract. Roles and responsibilities are defined in the Commonwealth of Virginia's Construction and Professional Services Manual (CPSM), March 31, 2002, Revision 5 (The Capital Outlay Manual).
3. Terms such as "George Mason University," "GMU," or "the University" used in these Guideline Standards refer to the Facilities Planning Office (Project Manager), especially when approval permission or consultation is referenced.

## ***Invoicing***

1. See the Construction and Professional Services Manual (CPSM) section 315.
2. No deduction shall be made from the A/E fee for any penalty or liquidated damages charged to any Contractor. No additional compensation shall be made for preparation of Alternates, unless the Owner prior to execution of the work approves such additional compensation in writing.
3. During Pre-Design Analysis (Programmatic Phase), Schematic design, Design Development, and Contract Documents and Bidding, the University will make monthly payments to the A/E based on the progress of the work as outlined in the Commonwealth of Virginia's Construction and Professional Services Manual (Capital Outlay Manual). Such payments shall in no event exceed the fee limits for phases as set forth in the contract. These payments will be limited in proportion to the Owner's estimate of progress and percentage completion of the work in the current phase. During Construction, the payments toward the fixed fee due for that phase will be made to the A/E in proportion to progress payments made to the Contractor for construction of the Project, as certified by the A/E.
4. Use format in the Construction and Professional Service Manual (CPSM), Appendix C.
5. The A/E cannot proceed on change orders without the written authorization from the University. Change orders cannot be billed without such authorization. See CPSM section 605.1.1.
6. All change orders shall be sequentially numbered when approved. The revised contract amount shall be shown on the invoice along with the original contract amount and the

previous contract amount if more than one change order. Invoices shall follow the same format as previously described.

## **Drawing Standards**

### **General**

All drawings shall be oriented in the same way.

### **Electronic Format**

1. Use AutoCAD v14. See also MOU.
2. Use National CAD Standards and The Uniform Drawing System which includes the accepted CAD layer guidelines. See also MOU.

### **Bid Documents**

1. At the time of bid advertisement, provide one electronic copy on CD ROM and 5 paper copies of bid drawings to the University. See also MOU.
2. The original bid set of drawings shall be on Mylar.

### **Record Drawings**

1. Upon completion of record drawings, provide two paper copies to the University for review.
2. Following University review, and incorporating comments as applicable, provide on copy of final Record Drawings on Mylar, and one electronic copy on CD ROM.

### **Size**

30"x42"

### **Lettering**

See the Construction and Professional Services Manual section 802.6.

### **Title Sheet**

See the Construction and Professional Services Manual section 802.1.1. In addition, the title sheet shall include: GMU logo, maximum 3" high, minimum 2" high; name, address, phone number, fax number, and email address of the A/E and any consultants used on the project.

## **Title Block**

The A/E may use his / her standard title block provided it contains the following minimum information:

1. A/E firm name
2. Project name and location
3. Campus name
4. Date drawing was completed
5. Scale of drawing unless noted under each detail
6. Sheet number and drawing number
7. Unique Drawing Number
8. Revision block: indicate revision issue, revision made by, revision date, revision approved by, and revision description. Block shall include at least 6 lines for revisions.
9. Project Name: shall match the title of the project on the project budget analysis sheet (PBA).
10. Project Number: cross-referenced to budget number.
11. Building Number
12. Area large enough for A/E's signature and seal
13. Approval block: for the signature of the University to approve the drawing

## **Drawing Arrangement and Number**

1. See the Construction and Professional Service Manual section 802.2 and 802.9.
2. Additionally, use "FS" for food service, "FL" for interior design or furniture layout, "LF" for laboratory furniture, and "U" for utilities.

## **Unique Drawing Number**

The University has a drawing numbering system that must be adhered to and used on all drawings. At the completion of a project by the A/E, a disc with each drawing title and corresponding number shall be transmitted to the University.

### **Unique Drawing Number Assignment**

1. A review of the project by A/E is conducted to ascertain the amount of each type of drawing required (i.e. 5-T, 10-C, 15-A, etc.).
2. A request is made to the University Facilities Construction Drawing Archival Branch for a total amount of unique drawing number assignments affecting the project, including all divisions, and reserving additional numbers in the same numbering sequence to insure project number continuity.
3. The University Facilities Construction Drawing Archival Branch will maintain a hard copy project log designed to follow projects from inception to completion. The log will contain drawing and project status on an on-going basis.

## Unique Drawing Number Samples

1. Abbreviations: ARL = Arlington Campus; FFX = Fairfax Campus; PWI = Prince William Institute.
2. A sample unique drawing number will look like this: ARL0573A0001, which consists of the campus (ARL for Arlington), building number (0573), drawing type (A for Architectural), and sequence number (0001) respectively.
3. A sample unique drawing number for a utility drawing will look like this: PWI0000U0001, which consists of the campus (PWI for Prince William Institute), building number (0000 for all utility drawings), drawing type (U for Utilities), and the sequence number (0001) respectively.

## New Drawing Release Procedure

1. All fields in the title block area of the drawing are to be completed, and a comprehensive description of the project and drawing title is mandatory for documentation and future reference.
2. The University must sign all drawings to be released.
3. For original drawing issues (i.e. issued for bids, addenda, record drawings, etc.), the issue column in the revision block area will display a dash line (-). The revision description must also be noted (i.e. "Issued for Bids", "Issued for Addenda", "record drawings").
  - For example: - H.C. 12-6-94 R.O. ISSUED FOR BID ("-" for original issue, issued by H.C., issue date 12-6-94, issue approved by R.O., and issue description ISSUED FOR BID).
4. In the event that a new drawing is created from information extracted and modified from any file drawing, a cross-reference notation in the revision block of the file drawing is to be made to reference the new drawing.

## Drawing Revision Procedure

1. A reproducible copy of the original drawing to be revised is made. Revisions are to be made to the reproducible copy. The original drawing remains intact with the exception that it will be marked "superseded by drawing No. \_\_\_\_\_."
2. The University Facilities Construction Drawing Archival Branch assigns a new unique drawing number to the revised drawing, and also records this number on the superseded original drawing. This will cross reference the two drawings and render the previous issue (on the superseded drawing) intact.
3. The revised drawing is also marked with a reference to the unique drawing number of the original (i.e. "revises FFX0025A0025").

4. Make the change to the copy of the original drawing, and indicate the revision description in the revision block area.
5. The revision issue column in the revision block area will utilize the alphabet (circumscribed by a triangle) to identify each revision.
  - For example: A H.C. 9-9-94 J.R. CHANGED (Revision A, revision made by H.C., revision date 9-9-94, revision approved by J.R., revision description – CHANGED).

## Room Numbering

1. GMU has adopted a standard method of handling room numbers which should be applied from the earliest possible point in the design process and carried throughout to completion. The A/E shall use the GMU Room Numbering System on all drawings. At design development completion, the A/E will work with the Project Manager to develop room numbers consistent with the University system. Consistent room numbering will facilitate matters for numerous organizations including Scheduling and Space Management, Inventory Control, Fire and Emergency Services, and the Facilities Maintenance Services concerned with the Construction Process. The following procedure shall be followed by all A/E's:
2. The system depends on some basic definitions as follows:
  - a. Corridor: A space normally used for pedestrian traffic, at least 5 feet wide and enclosed by solid walls.
  - b. Vestibule: A space used for traffic that is a point of ingress or egress to a building, with doors on two walls.
  - c. Room: A clearly defined space not normally used for through traffic and enclosed by solid walls.
  - e. First Floor: The lowest floor of any building which is at least 50% above surrounding grade.
  - f. Lobby: A space used for traffic that is a point for ingress or egress to a building or floor from upper or lower floors.
3. In general, room numbers will consist of three digits with the first digit designating the floor. Basement rooms will use a zero (0) as the first digit. If there are floors below the basement the room numbers should be developed on a special basis with the appropriate Facilities Design Personnel.
4. In general, all floors of the building should have similar patterns. Numbering patterns should begin at the end of the corridor nearest the main entrance or lobby. Even numbers should apply to rooms on the right side of the corridor and odd numbers to rooms on the left, moving away from the entrance. Numbers should be in direct sequence, and only one number should be applied to one room regardless of the number of doors to that room



off the corridor. Rooms which have no direct entrance from a corridor should be designated by adding a letter after the number of the room through which they are entered from the Corridor (101A). If they can be entered through more than one room, the number of the room most frequently used to gain access should be used

5. This system assumes a fairly simple floor plan, a situation that seldom occurs in actual practice. Most new buildings have complicated floor plans designed to suit a specific purpose without consideration for creation of any rigid geometric order, and numerous alterations and additions to older buildings often wreak havoc on established room numbering. However, it is possible to establish a fairly reasonable room numbering plan for virtually any building, provided that the basic rules are applied and tempered with common sense and judgment. It is essential that the numbering system for new buildings or renovated buildings be developed by someone thoroughly familiar with the system and the University.
6. Once the basic floor plan is established, prints shall be submitted to the Facilities Planning Office where the room numbering system will be marked on the prints by the University Space Management Office. Room numbers will be indicated with a rectangle drawn around each number. The marked prints will be returned to the A/E with instructions to adhere to the established room numbers on all subsequent submissions. Inevitable changes arising during the design process, as they affect room numbering, will be cleared with the Project Manager.
7. Doors should be numbered with a system which reflects the room number to which the door allows access. For example, the door to room 104 should be labeled "104/1" or "104/A" or similar system.

## **Foundation Elevations**

Foundation elevations shall be shown at elevation of suitable bearing.

## ***Specification Standards***

### **Coordination**

See the Construction and Professional Services Manual section 901. Specifications should be coordinated so that issues are addressed only once, and conflicts are avoided. For instance, the engineering specifications should not reiterate the number of shop drawings needed, or mention additions to the Bid Form. These problems often arise when the Architect uses consulting engineers. The Architect is responsible to review the engineers' specifications and coordinate such items. Make sure that specifications from consultants are submitted to the Architect in enough time to perform this review.

### **Format**

1. Use the Construction Specifications Institute (CSI) MasterFormat™, 1995 Edition, for all specifications. Format should be consistent throughout the entire specification.

2. All articles, paragraphs and subparagraphs should be numbered or lettered in outline form for easy reference.
3. Section Number and Title should be boldly indicated at top of first page of Section. The first Section of each Division should also indicate the Division name and title.
4. Each Section should end with "END OF SECTION" to indicate that this is the last page of the Section. Each page of the Section should have the Section number and page number (sequentially numbered) centered at the bottom of the page. Reason: In printing process it is possible to misplace a page or get pages in wrong order. The Contractor can easily determine that he has all proper pages by checking the sequential numbers and will know he has the last page with the "END OF SECTION" indication. All pages of the specification are to be sequentially numbered from page 1 to the end of the Division 16. This must be performed just prior to printing when the entire specification is complete and is most easily accomplished by using one of the large type numbering machines.

## **Proof Reading**

The A/E is responsible to insure that all specifications are proofread. The omission of simple words as "not" will completely change the meaning of a sentence. Also, in the proofreading process, additional thoughts or changes in text are often caught and can be corrected.

## **Prohibited Language**

See the Construction and Professional Services Manual (CPSM) section 803.10. The following words, phrases, and clauses are expressly prohibited:

1. "Plumbing Contractor", "Food Service Contractor", etc. All construction work is bid through single prime Lump Sum General Contracts. Under this type of contract the General Contractor is responsible to perform all work required. It is the General Contractor's business decision as to how the work will be divided amongst their subcontracts (see also CPSM section 803.10.3). **The only exceptions** are for automated building controls and building access systems where GMU uses specific manufacturers.
2. The note "by others" or Not in Contract (NIC). If this is the case, name the specific contractor or agent to provide the item. See CPSM 803.10.6.
3. The words "This Contractor shall..." or "The Contractor shall..." to begin instructions to a contractor. These words are redundant since all instructions are directed to the General Construction Contractor.
4. The words "alternate" to indicate an "option". The word "alternate" should be used only for alternate work which is specified in the technical sections of the specifications and must be included in the bidders' proposals. The word "option" should be used to indicate items for which the contractor may make a choice without affecting the contract. All options must be approved by the University prior to construction in which case either the change will be done at no increase in cost to the project or as a credit or deduct.

5. "Is", "are", or "will be". Use the word "shall", or put in imperative mood. This is particularly a problem when copying specifications provided by manufacturers which are used as a sales tool. Remove text which indicates the advantages for using this product or other text designed to sell you on its use rather than indicate the nature of the material or its proper installation.
6. Avoid abbreviations and symbols such as #, @, &, and w/.
7. When referring to George Mason University, use the terms "Owner" or "University". Do not use "Using Agency" or "State".

## **Codes and Code Compliance**

See the Construction and Professional Services Manual (CPSM) section 700.

### **Barrier Free Design**

1. All designs for new construction and renovations to existing facilities shall be designed and constructed in such a manner that the new or renovated facility is readily accessible to and usable by individuals with disabilities consistent with all applicable state and federal mandates. Specifically, design and construction shall be done in compliance with the following:
  - a. The Uniform Federal Accessibility Standards, April 1 1988 (UFAS) adopted under the Americans with Disabilities Act of 1990, Title II, Part IV, Department of Justice, 28 CFR Part 35, Nondiscrimination on the Basis of Disability in State and Local Government Services: Final Rule #. ANSI A117.1, ADAAG, and VUSBC Chapter 11 are superseded by the Federal Law. Guidance on the application of the code and provisions by the authority having jurisdiction (DEB) are provided in the CPSM Chapter 7.
  - b. Section 504 of the Rehabilitation Act of 1973 ("Section 504") and supporting regulations thereto;
2. Beyond mere compliance, every design component should be examined for its impact on persons with disabilities and adjusted to achieve the optimum balance between user requirements and convenient access to individuals with disabilities. At the 35% design phase of the project, there shall be a consultation with the University to review the project design with reference to applicable federal and state standards.

## **Materials and Equipment**

Specify only established products. Do not specify prototype or new materials and equipment. See also the Construction and Professional Services Manual section 803.9.

## **Earthwork Specifications**

This section of the Specifications shall contain all earthwork requirements for the project. Divisions 15 and 16 shall cross reference the Division 2 Earthwork Section. Do not repeat or reiterate earthwork requirements in Division 15 or 16 to avoid conflicts and confusion.

## ***Estimating Standards***

See the Construction and Professional Services Manual (CPSM) section 804.

## ***Area and Volume Calculations***

See the Construction and Professional Services Manual (CPSM) section 701A.

## ***Subsurface Investigation***

1. See the Construction and Professional Services Manual (CPSM) section 902.
2. At least two borings will be required for parking lot areas and major roadways, in addition to the borings requested for the building itself. The minimum borings for a building shall be six with one boring for every 2,500 sq. ft. of built over area. Borings shall be to depth no less than the expected depth of excavation for the project.
3. Show results on the drawings.

## ***Storm Drainage***

During design, consider storm runoff from all areas surrounding the site in addition to storm runoff from the site and adjacent sites. Prepare calculations to support design. Calculations shall be submitted to the University.

## ***Construction Change Order Procedures***

See the Construction and Professional Services Manual section 1019. The only changes which will be made are:

- Changes to meet code requirements
- Changes to make the building function properly
- Changes due to field conditions

## **Permit Documentation**

1. See the Construction and Professional Services Manual (CPSM) section 504.3.
2. Prior to putting the project out to bid, the A/E shall provide the University with the necessary documents to allow GMU to file with the appropriate Soil Conservation District (a site plan indicating the proposed soil erosion and sediment controls as required for each project). The University requires that the SCD permit be obtained at 90% design completion. The Consultant shall provide GMU with the necessary 100% complete SCD plan for submission to the appropriate district. The A/E shall assist in all follow-up correspondence. The University shall be the prime contact with the conservation district. The SCD approval process takes approximately 4 weeks. This scheduling time should be taken into account so as not to delay bidding or the project as a whole. Remember all permits shall be in hand before the project is bid. The Soil Erosion and Sediment Control Plan shall meet the requirements of the appropriate District Office. See CPSM section 702B.
3. Storm Water:
  - a. **Disturbance of land exceeding 1 acre** requires submission of a storm water management plan with calculations to the Department of Conservation and Recreation, Division of Storm Water Management.
  - b. **Disturbance of land exceeding 5 acres** or more a discharge permit from the Department of Environmental Quality is required. The A/E shall prepare all necessary documentation so the permit can be obtained at 90% design completion. See Soil Erosion and Sediment Control Plan section above for details on sequencing this work.
4. Freshwater Wetlands Permit:
  - a. During the site investigation phase, the A/E shall examine the area for the presence or absence of wetlands within 100 linear feet of the proposed disturbance. Should the presence of wetlands be suspected, the A/E shall immediately bring this to the attention of the Project Manager. Any cost or schedule impact as a result of suspected wetlands shall be reviewed with the University.
  - b. Furthermore, the A/E shall delineate, or have delineated by a licensed surveyor or environmental consultant, all suspected wetlands on site. Design will accommodate found wetlands and their attendant transition areas and appropriate permit applications and or mitigation plans will be applied for and secured by the A/E prior to bid of project. See Soil Erosion and Sediment Control Plan section above for details on sequencing this work.
5. Stream Encroachment Permit: If the project will impact a stream or drainage swale, this shall be reviewed with the Project Manager. If a stream is encountered, then the attendant stream encroachment permit application shall be made by the A/E using the services of a licensed surveyor and or environmental consultant. The permit shall be secured prior to bid of the project. See Soil Erosion and Sediment Control Plan section above for details on sequencing this work.

## ***Demolition Materials***

Check with GMU recycling services to determine if any materials from demolition are suitable for recycling.

**End of Section**

# **PART II – FACILITIES AND SPACES**

## ***Master Plan***

### **Design Character**

1. Buildings should extend and enhance the underlying planning and architectural strengths of the campus.
2. New buildings should balance individual expression with contextual sensitivity.
3. New buildings should reflect the character of the university as an institution with a rich past, vibrant present, and promising future.
4. Program, site, and budget parameters should all be addressed in an integrated fashion.

### **Planning**

1. Buildings should be sited to reinforce and enhance the spatial structure of the campus and its circulation patterns.
2. Building entries should be clear and coordinated with circulation patterns and landscaping elements.
3. Ground level uses should consider the harmony of interior and exterior activities.

### **Massing**

1. Massing should be simple.
2. Buildings should be tall enough to define adjoining spaces. This will require a minimum 3-story or 45 feet high building.
3. Bays, porches, towers, and other minor adjustments to massing are encouraged.

## **Roof Forms, Roof Lines and Silhouette**

1. Well-developed and articulated rooflines are encouraged.
2. Sloped roofs and flat roofs are both acceptable.
3. Sloped roofs should be of high quality self finished metal. See CPSM section 707B.
4. Flat roofs should have carefully selected aggregate or pavers if visible. Visible Roofscapes must be as carefully designed as any other exterior surface of the building.
5. It will be necessary for designers to explain all aspects of their design selection including material, color, patterning, and other details.
6. Parapets should be well articulated and trimmed with cut stone. Profiles and scuppers are acceptable. Other ornamental devices must be approved by GMU.
7. Dormers and pediments are also acceptable and encouraged as are cupolas, chimneys, and other traditional roofing embellishments. Their intersection with the main roof must be well detailed and will receive careful scrutiny. These elements should not be viewed purely as ornamental elements without functional attributes.

## **Facades**

1. Facades should be simple and well ordered.
2. General fenestration patterns should be regular. Some vertical hierarchy is appropriate. Where affordable, cut stone window surrounds are preferred to precast concrete. Window openings should be subdivided to create a vertical proportion where they form horizontal groupings.
3. The use of bays, giant order elements, or special accents to provide a large overall order must be approved by GMU.
4. Special detailing ornament and materials at significant locations must be approved by GMU.
5. Window frames and glass should be set back approximately 6". Sills and heads should be detailed to shed water and alleviate the possibility of unattractive weathering patterns.

## **Architectural Details**

1. Buttresses, coping, string courses, and other traditional architectural details are acceptable and encouraged.
2. The joining of dissimilar materials must be resolved carefully and will be rigorously reviewed.

3. Where possible, caulk joints should be placed in less visible locations such as inside corners or reveals.
4. Extreme care and experienced oversight should be given to details designed to prevent water infiltration.

## **Ornament**

1. The campus currently has minimal ornament reflective of its lengthy history. Future buildings should have well-developed ornamental programs appropriate to a University with such a broad contemporary mission.
2. Heraldry, plant, animal, and geometric motifs are all acceptable and encouraged in a coordinated program.
3. Building identification integrated into building facades are key elements of an ornamental program.
4. The use of new technologies to economically produce ornamental elements is acceptable and encouraged.
5. The creative use of masonry patterning is also acceptable as an ornamental strategy.

## **Masonry**

1. Material selection should be made to reinforce existing campus patterns.
2. Masonry design must comprehensively consider unit size, texture, color, hording pattern, mortar, and striking. These design choices will be rigorously reviewed.
3. Pre-cast concrete, poured-in-place concrete, and cast stone may be proposed as alternatives to limestone trim.

## **Exterior Doors**

1. Wood, metal, and glass doors are all acceptable.
2. Doors should have a quality and character appropriate to the overall façade.
3. Vision panels, reveals, and carving are appropriate and encouraged.

## **Color**

1. Exterior Colors: Significant exterior colors such as brick, mortar, window and curtainwall frame and window colors, etc. shall be established early in the construction stages. These colors shall be reviewed and approved by the University. A mock-up panel shall be made by the Contractor in order to approve final colors and workmanship. Color choices for brick must be coordinated with the existing campus and reinforce the overall campus design



2. Interior Colors: The Interior Design Consultant or Architect will select colors of interior finishes early during construction. The A/E shall obtain submissions from the Contractor on all manufacturers and products that the Contractor intends to use on the project. Using the standard or special colors from these manufacturers, the Interior Design Consultant or the A/E shall prepare a color board indicating the various spaces and the color schemes for each space or series of spaces. These color boards shall be submitted to the GMU Project Manager for review and approval at a point early in the construction process and no later than the date that structural elements of the building are 50% complete. Upon approval of the colors, the A/E shall develop a detailed listing for the Contractor indicating the colors selected for each material and location on the project.
  - a. Carpet: Avoid solid and light colors. Use flecked colors and shades that don't show dirt and stains as readily.
3. The A/E shall carefully monitor submissions from the Contractor, especially on those items requiring color selection and shall remind the Contractor of any submissions not made which may hold up the color selection. The A/E is encouraged to include in the Specifications clear instructions to the Contractor to make this process as painless as possible.
4. The official GMU "Green" color is represented by Sherwin William, Industrial Enamel, Green (SW-4072). Although this is the official "Green" color, it is not intended to indicate a standard paint manufacturer. Many other paint and coating manufacturers can match this color.

## **Space Requirements**

Space planning for new university facilities shall generally follow the guidelines in Section 701.B of the Commonwealth of Virginia Construction and Professional Services Manual. In addition to those guidelines, the following space guidelines shall be used. The Architect/Engineer shall document specific space allocations based on these guidelines and the requirements of the project in design during the programming and schematic design phases for review and acceptance by the University. These space allocations will become the basis for the development of the project design.

### **Administrative and Faculty Offices**

| Administrative & Faculty Offices  | Area Guideline |
|---|----------------|
| Vice Presidents; Deans  | 256 sf         |
| Associate Vice Presidents & Deans, Assistant Vice Presidents & Deans, Directors reporting to Vice Presidents, Deans and the President | 192 sf         |
| Department Heads  | 168 sf         |
| Associate and Assistant Department Head   | 144 sf         |
| Faculty   | 120 sf         |

## Custodial/Housekeeping Spaces

The following office spaces should be incorporated into the design of new buildings in order for the Physical Plant Department to provide adequate custodial and preventive maintenance services to the building occupants:

1. Custodial Closet: Provide a minimum of one (1) 7' x 8' closet for equivalent space on each building floor (2 closets required on floors greater than 18,000 SF). Additional space may be required depending on the building floor square footage. A minimum of 5' x 7' with a floor sink mounted in a corner. This sink will not be over 8" in height. There will be a mop holder over the sink that will accommodate up to three mops. One wall will have at least three shelves, spaced a minimum of 18" apart and be at least 18" deep. The bottom shelf will be a minimum 24" from the floor. The length of the shelves will be the same as the wall. The shelving can be either wood or steel. The shelves will not be mounted on the same walls that come in contact with the sink. There will be one light fixture suitable to properly illuminate the closet. The closet will be ventilated. The floor will be sloped to a center floor drain sized for this space. The floor will be sealed concrete. The closet door should be hinged to open out and not into the closet. The walls shall be painted a shade of white to enhance the lighting.
2. Custodial Supply Closet: Provide one supply closet located on a floor level accessible from a service entrance or loading dock (not within the proximity of any custodial closet), containing a minimum area of 100 square feet. One wall will have adjustable shelving that is 24" deep (four total) with the bottom shelf being 24" from the floor. Shelving will be made of wood that has been treated with a wood sealer (not pressure treated) or painted steel. Shelving will not be mounted on the walls that come in contact with the sink. There will be one floor sink located in a corner furthest from the door. There will be one mop holder capable of holding three mops located over the sink. The floor will be sealed concrete sloped to a floor drain located in the center of the room sized to the room size. Lighting will be sized to properly illuminate the room. The wall will be painted a shade of white. There will be at least one duplex receptacle, 120 VAC, located away from the sink, but not on the shelving wall. The room shall be ventilated.
3. Housekeeping Supervisory Office: The supervisor office will be a minimum of 8' x 10'. It will have one duplex receptacle located on each wall. The door will be solid wood and equipped with a door reinforce plate to discourage force entry. There will be a drop ceiling composed of 2' x 2' ceiling tile and recessed lighting. Florescence lighting properly sized will be used. The floor will be tile or carpet. This space will be connected to the building's HVAC for climate control. There will also be one wall mounted key box, 20 gage steel minimum, baked enamel finish, gray color, with concealed hinge, key type lock, 12" x 12" x 2" minimum size.
4. Preventive Maintenance Office: Provide one (1) 12' x 12' office or equivalent space in each building, located on the ground floor of the facility in close proximity to the loading dock.

## Recycling Spaces

The following recycling related office space and equipment requirements should be incorporated into the design of new buildings to facilitate waste stream separation and removal:

1. Offices: Provide desktop space for double-compartmented paper collector (10"W x 9-1/2"D x 11"H) or floor space for Deskside three (3) compartmented trash and paper collector (10-3/8"W x 19-3/8"D x 13-5/8"H).
2. Copy Rooms: Provide floor space for one (1) thirty (30) gallon rectangular paper collector (21-3/4"W x 15-5/8"D x 27-5/8"H) for every two (2) copiers (collector to be emptied once a week).
  - Note: For rooms with multiple high speed copiers, provide floor space for one (1) thirty (30) gallon rectangular paper collector (21-3/4"W x 15-5/8"D x 27-5/8"H) for each copier (collector to be emptied daily).
3. Lounges/Mail Rooms: Provide floor space, or alcove, for three (3) rectangular thirty (30) gallon collectors for aluminum cans, newspapers, office paper (21-3/4"W x 15-5/8"D x 27-5/8"H).
4. Corridors:
  - a. Provide floor space, or alcove, for two (2) rectangular thirty (30) gallon paper collectors (21-3/4"W x 15-5/8"D x 27-5/8"H) for every ten (10) office workers (collectors to be emptied once a week).
  - b. Provide floor space, or alcove, for one (1) rectangular thirty (30) gallon aluminum can collector (21-3/4"W x 15-5/8"D x 27-5/8"H) for each soda vending machine.
5. PC Labs: Provide floor space, or alcove for one (1) thirty (30) gallon paper collector (21-3/4"W x 15-5/8"D x 27-5/8"H) for each printer (collector to be emptied once a week during normal periods, 2-3 times per week during peak periods).

## Trash / Recycling Rooms for Student Housing

1. Provide trash / recycling room(s) on each level to accommodate two 40 gallon trash cans, one for recycling and one for trash, per 15 students.

## Loading Docks

1. Loading dock should be an "L" shaped design. Provide floor space along the long leg for multiple storage containers (37-1/2"W x 30-1/2"D x 43"H), one (1) per recyclable. Provide bumpers and dock leveler at each loading dock.
2. Exterior loading dock area should be enclosed with an overhead door, or at a minimum, sheltered from the elements by an overhanging roof.
3. Locate loading dock near the mid-section of the building, rather than at either end.

4. Loading dock should be directly accessible by a service elevator having a 2500 lb. usable capacity.
5. Provide a 60” cardboard bailer in close proximity to each loading dock area if facility generates more than six (6) cubic yards of cardboard per week and does not have an open hopper with cardboard compartment.
6. Consider truck loading dock fumes in relation to make-up air and building openings

### **Telecommunications Closet**

1. Telecommunications closets should be centrally located away from building corners and in close proximity to electrical service. Ensure adequate cooling capacity is provided to these closets to prevent equipment overheating. Limiting the distance between these facilities will include designing an optimal grounding arrangement and minimize intersystem grounding disturbances. A #6 ground should be provided in all telecommunications closets.
2. Size Requirements are based on distributing telecommunications service to one individual work area per 100 sq. ft. of occupied floor space. Minimum telecommunications closet sizes are shown in the table below:

| IF THE SERVING AREA IS:                 | THEN THE CLOSET MUST BE AT LEAST |
|---|----------------------------------|
| Less than 5,000 sq. ft.                 | 10 ft. x 7 ft.                   |
| Between 5,000 sq. ft. and 8,000 sq. ft. | 10 ft x 9 ft.                    |
| Larger than 8,000 sq. ft.               | 10 ft. x 11 ft.                  |

3. All Walls of the closet shall be lined with rigidly installed wall-to-wall framing of 3/4” trade size A-C plywood, 8 ft. high. Backboards shall be rigidly installed and painted with a nonconductive fire-retardant overcoat.
4. The temperature of the room shall be kept between 64°F and 75°F.
5. Humidity in the telecommunications room shall be kept between 30% and 55% of relative humidity.
6. Floors shall be static free (using asphalt / linoleum tile).
7. Lighting intensity shall be at least 50 foot candles at 3 feet above the floor.
8. Emergency lighting shall be provided.
9. The rated distributed floor loading shall be greater than 250 psf.
10. The rated concentrated floor loading shall be greater than 1000 lbs.

11. Telecommunications closets shall not have door sills or center posts. The door shall be 7' H X 3' W.
12. Sleeves or dam walls around floor slots shall extend 4 inches AFF.
13. Conduits and cable trays located in ceilings shall protrude 2" into the closet.
14. Ventilation shall accomplish one air change per hour (minimum).
15. Closets shall include a minimum of 2 dedicated 110 V AC 20 ampere quad outlets on separate branch circuits.
16. Each floor of the building should have at least one centrally located closet. These closets should be vertically stacked and connected with four - 4" sleeves for a clear cable pull without offsets extending 2" AFF and below ceiling level on the lower floor. Conduits, reamed and bushed at both ends are to be installed with a minimum 200 lb. test pullwire and no more than two 90° bends without a pull box being placed (See the attached diagram for pullbox installations. Bends are to be 10 times the I.D. for all conduits. The sizing and placing of pull or splice boxes shall not be used in place of 90° bends.

## **Pay Telephones**

Provide space for locations of pay telephones installed/owned by GMU.

## **Classroom Specialties**

Classroom specialties such as chalkboards, tack boards, projection screens, and seating vary significantly depending upon the ultimate use of the space. The A/E should work closely with university personnel to identify the needs of each room.

## **Health-Safety Requirements**

### **Classroom Configuration**

Rooms designed for a capacity of more than fifty (50) students must have two separate exit doors, and all classrooms must have posted occupancy signs.

### **Laboratory, Shop, Studio, and Office Layouts**

1. Egress from a low hazard area (office, conference room) may not be through an area of higher hazard (laboratory, shop, many art studios, darkroom, etc.). Where possible, the office area should have at least one exit directly into a corridor.
2. Office space and/or a break area where workers can eat or drink must be located conveniently and sufficiently close to, but not in, laboratories, shops, art studios, etc.

## Work Space

Provide adequate working or use space around equipment and furnishings. In general, 30" of free floor area is required for operations done while standing, and 36" of free floor area is required for seated operations, aisles, passageways, and doorways. These are minimums which should be increased depending on many variables including occupant traffic capacity, size of material used in an operation, and facility use.

## Decontamination facilities

Decontamination facilities such as sinks for hand washing and storage of clean clothes, should be designed into each laboratory, shop, studio or other such space. These facilities should be located close to the exits to less hazardous areas.

## Hazardous Operations Areas

The most hazardous operations areas, such as fume hoods or chemical storage areas must be located away from exits.

## Egress

In rooms, such as laboratories, chemical storage rooms, and others where hazardous materials are used or stored, separate, remotely located doors are highly recommended and must be installed whenever possible. Such spaces must have a second door when travel to the door from the most remote point in the room exceeds 50 feet. Teaching laboratories should have two doors, and should be configured to avoid dead-end aisles between benches, other furnishings, and permanent partitions. Bench runs in all laboratories should be placed perpendicular to the main door so that normal circulation patterns are towards the exit.

## Darkroom Ventilation

1. Darkrooms where wet chemicals are used must be furnished with local exhaust ventilation to control airborne levels of photographic process chemicals. This shall be in the form of a flanged slotted plenum running the length of and behind the work area where chemicals are used. A capture velocity of 50 linear feet per minute (LFM) must be provided at the front edge of the work area. The required exhaust flow rate to produce this capture velocity shall be calculated by the following formula:

$$Q = 2.6 LVX$$

Where:

Q = Volumetric flow rate in cubic feet per minute (CFM)

L = Length of work area, in feet

V = Desired capture velocity (in this case, 50 LFM)

X = Distance from slot to front of work area, in feet

2. Once the required flow rate is determined, the slot width shall be sized to provide a slot velocity of approximately 2000 feet per minute. The plenum shall be sized to

provide a plenum velocity of approximately half the slot velocity. (Taken from the ACGIH Industrial Ventilation Manual, 22nd Edition.)

### **Lounge Areas**

Lounge and eating areas must be provided in all wet laboratory, shop and studio buildings. There should be sufficient areas convenient to all laboratories to discourage eating and drinking in and continuous occupancy of, potentially hazardous work areas.

### ***Security Conscious Design***

Increased security and crime prevention can be brought about through the use of environmental controls. These controls include natural surveillance, natural access control, territorial reinforcement and maintenance as outlined below:

1. Natural Surveillance: Maximize visibility with strategic placement of architecture and physical elements.
2. Natural Access Control: Place entrances, exits, fencing, landscaping and lighting to control movement of people and vehicles.
3. Maintenance: Maintain landscaping, buildings, lighting, etc. in order to maintain visibility, preserve pride in ownership and continue declaration of ownership.

**End of Section**

## **PART III, BID DOCUMENTS**

### ***Project Manual / Specifications Arrangement***

1. See the Construction and Professional Services Manual (CPSM) section 803.2.
2. The final copy should be paginated before printing by the A/E.
3. For final printing, specifications must be printed double sided. Each new Section or Division should start on the right hand side of the book.

### ***Bidding Procedures***

See the Construction and Professional Services Manual (CPSM) section 504.4, 809, 810.

### ***Bid Document Distribution***

A/E or Facilities Planning Office distributes Bidding documents, including addenda. Projects may be bid via a selected list of pre-qualified bidders, which is developed GMU. The list may not be published until it has complete approval.

### ***Addenda***

The A/E is to prepare addenda as required. A standard Addenda format and language is stated below. Addenda shall be forwarded to the Facilities Planning Office for review and if acceptable, distribution. The cut-off for distributing addenda is 10 days prior to the bid opening. See the Construction and Professional Services Manual (CPSM) section 1003.3 for exceptions.

“The information contained herein revises, supplements and/or supersedes the specific parts of the documents referred to, and shall be attached to and become part of those documents as if originally forming a part thereof. Except as herein modified, all other provisions of the documents shall remain in full force, unless otherwise described in this Addenda, shall comply with the requirements originally specified for similar work.”

### ***General Conditions***

1. The Architect / Engineer (A/E) must review the General Conditions, CO-7, to become familiar with the terms and conditions of the Construction contract and to prevent conflicts between the A/E's technical specifications and the General Conditions. When conflicts occur, the Supplemental General Conditions, the General Conditions (CO-7's), and Special Conditions (SC's) take precedence over the technical specifications. The General Conditions are NOT to be edited or altered in any way by the A/E.
2. Just prior to printing the final specifications for bidding, the A/E is to schedule a meeting with the Project Manager to confirm the use of the most recent set of Instructions to Bidders



(IB), Contract Forms and CO-7's in the documents. The A/E will be required to have a statement of work (limited to one page), a form for pricing additive bid items, and the number of consecutive calendar days to be given to construct the project. The A/E is not to make any changes to the standard boiler plate CO-7. Supplemental General Conditions are allowed.

### **End of Section**

## **PART IV - CONSTRUCTION PRODUCTS AND ACTIVITIES**

### ***Division 1: General Requirements***

#### **01300: Administrative Requirements**

##### **01320: Construction Progress Documentation**

###### **Construction Photographs**

The contractor will take construction photographs once a month. Photographs shall show each building elevation. Photographs shall be digital. One paper print of each photograph taken and the photos on 3.5" disk will be forwarded to the A/E and GMU on 3.5" disks for their files.

###### **Construction Schedule**

###### **A. General**

1. In accordance with the General Conditions, paragraph 19, if the contract price is greater than \$1.5M, a Critical Path Method (CPM) schedule is required.
2. The Contractor's CPM Construction Schedule shall consist of a computerized network diagram together with a mathematical analysis of that network.
3. Display accepted schedule in time-scaled logic network diagram format at site construction office at all times and review with Subcontractors each week.
4. CPM schedule shall clearly show sequential interdependencies.
5. The approved Scheduling Software System shall be capable of baseline comparison analysis. Store (save) an original version of the approved Contractor's CPM Construction Schedule as the baseline "As-Planned" schedule for comparative analysis. As work progresses, provide graphics displaying actual progress bars versus baseline or target bars.

6. Activity durations shall be in work days. The maximum duration for any on-site work activity shall be twenty (20) work days.
7. A sufficient number of activities shall be utilized to accurately depict reviews and approvals, fabrication and delivery, construction sequence, dependencies and progress.
8. Each activity shall be assigned a unique Activity ID number that shall not be changed once assigned. Use skip numbering of activities to allow insertion of additional activities for contract modifications and logic changes.
9. Clearly explain abbreviations used in CPM schedules in legend of symbols, either separate or attached.
10. Except for Contract Award, Notice-to-Proceed with Off-site Work, Notice-to-Proceed with On-Site Construction, and required interim and final completion milestones, activities shall not be constrained by any means other than logic ties to predecessor and successor activities. Relationships with start or finish lags may be used provided the lags are less than 7 working days and can be logically explained.

B. Activity Content:

1. CPM schedule should include, but not limited to, the following activities as they apply to the project:
  - (a) Construction tasks (maximum twenty (20) work days duration for any activity)
  - (b) Shop drawings submittal and approval process
  - (c) Ordering, fabrication, and delivery of major materials and equipment
  - (d) Check-out, start-up, and test and balance of major equipment
  - (e) Submittals of record drawings and maintenance manuals
  - (f) Cleanup and punch out tasks
  - (g) Important coordination activities required to insure timely support and/or inspections
  - (h) Owner purchase/install items and/or Owners separate contract work
  - (i) Pre-final, final inspections and Substantial Completion
  - (j) Punch-out and Final Completion
  - (k) Specified interim completion milestones

- (l) Owner occupancy
2. Schedule submittal activities to allow sufficient time for work to be procured and installed, even if submittal is unacceptable and resubmittal is required
3. CPM scheduling shall include anticipated events, such as electrical power change over and adverse weather.
4. The CPM Schedule shall account for the normal range of inclement weather and its impact on work operations. Please use the National Weather Service for historical climatological information for the appropriate campus.
5. The following required milestones and finish dates shall be indicated and adhered to:
  - (a) Contract Award
  - (b) Notice to Proceed
  - (c) Complete Roof (including roofing, flashing, skylights and all items necessary to prevent water infiltration to the interior).
  - (d) Complete Exterior Walls (not including facing, insulation, and windows).
  - (e) Complete Approval of Materials (including all initial submittal and approval of materials, excluding submittals for information, certifications, testing, and as-built information): Finish no later than 120 calendar days after Award of Contract.
  - (f) Substantial Completion
  - (g) Final Completion
6. Activities shall be coded to show, at a minimum, the following:
  - (a) Phase
  - (b) Area (e.g. Site, Building Area)
  - (c) Level (e.g. Foundation, Floor No., Basement, Roof, etc.)
  - (d) Responsibility (e.g. Subcontractor, Vendor, Supplier, Owner, Authority, etc.)
7. If the contract price is greater than \$10M, all activities shall be resource loaded for major equipment and manpower for individual major trades, except for submittal, approval, fabrication and delivery activities.

### C. Schedule Submittals:

1. Submit initial, complete CPM schedule, revisions, and monthly updates in one (1) paper copy and one (1) electronic copy.
2. Within sixty (60) calendar days after receipt of a signed contract, submit a complete CPM schedule for the project, consisting of a time-scaled network diagram, a tabular report with bar chart, and narrative. Allow fifteen (15) work days for Owner's review.
3. Submittal of initial and monthly CPM schedule charts shall include one (1) set of all reports as outlined below (Report Formats). Plots shall be in color. Critical path shall be clearly indicated in contrasting color.
4. Resubmit revisions to address Owner's review comments within (10) work days after review. An approved As-Planned Contractor's CPM Construction Schedule shall be a condition for processing the second pay request as well as all future pay requests.
5. Contractor's Superintendent and major Subcontractors shall participate in the development of the CPM schedule. Provide written certification of acceptance of the initial CPM schedule by the major Subcontractors with submittal.

### D. Schedule Narrative:

1. For the initial, complete schedule, provide a written narrative explaining the Contractor's plan for meeting the interim and final completion dates. Identify and explain assumptions, sequencing, material and equipment for major work categories and restraints such as manpower and academically sensitive items such as Final Exam week. The academic calendar can be found at <http://registrar.gmu.edu/calendars.html>.
2. Identify activities which are planned to be expedited by use of overtime or double shifts, including work on Saturdays, Sundays and holidays.
3. Describe calendars used and provide a listing of holidays, weather days and other non-work periods.
4. Define abbreviations used.
5. For monthly progress updates, provide a narrative that describes problem areas, current and anticipated, delaying factors and their impact, and an explanation of corrective actions taken or proposed.

E. Report Formats:

1. Reports and graphics are to be submitted each month and shall consist of following:

(a) A Tabular Report of all project activities with bar chart. Progress bar chart shall include target or baseline comparison bars. Bar positions shall be early start/early finish with float clearly defined. Sequencing of columns on Tabular Report shall match following:

- Activity/Task Description
- Original Duration
- Remaining Duration
- Percent Complete
- Early Start
- Early Finish
- Late Start
- Late Finish
- Actual Start
- Actual Finish
- Total Float

(b) Time-scaled Network diagram with schedule logic shown.

(1) Sequencing of columns on Time-scaled Network Diagram shall match the following:

- Task/Activity Name
- Original Duration
- Remaining Duration
- Percent Complete
- Early Start
- Early Finish
- Total Float
- Manpower Loading

(2) Critical Path shall be clearly identified.

(3) Group activities together by area and responsibility. Provide titles and subtitles to identify activity groups.

(4) Sheet size of diagram shall be 24 by 36 inches minimum and time scaled in weeks unless approved otherwise.

2. On each page include title block containing as minimum following information:

- Project Title
- Project Number
- Contractor's Business Name
- Date of Submittal and/or Revision
- Progress Computation Date (i.e. Data Date)
- Version Number (see below)
- Legend of Symbols and Abbreviation as applicable

F. Each CPM Schedule shall be identified by a two-part Version number separated by a decimal point.

1. The first part of the Version number shall reflect the Revision Number, beginning with "0" for the initial as-planned schedule. This number will be incremented each time the schedule is revised to add or delete activities, change logic or durations as approved by the Owner.
2. The second part of the Version number shall reflect the Update Number, beginning with "0" for the initial as-planned scheduled (no update information). This number will be incremented each month that the schedule is updated.
3. The approved as-planned schedule will be Version 0.0. The first monthly update for progress will be Version 0.1. By way of example, if the schedule were revised twice by the time of the sixth update, it would be Version 2.6.

G. Schedule Implementation & Monitoring

1. CPM schedule charts and reports updated for the current pay period shall accompany the Contractor's monthly pay request for work completed. Pay requests will not be processed without the required updated CPM schedule submittal.
2. Where the Contractor is shown to be behind schedule, provide accompanying written summary, cause and explanation of planned remedial action.
3. Failure to prepare, submit, and maintain CPM schedule as specified shall be cause for rejection of other schedules submitted and for possible delay of payment.
4. Float time belongs to the Project, not to the Contractor or to the Owner, and may be utilized by both parties.

## H. CPM Schedule Updates & Changes

1. Update CPM Schedule for actual progress (i.e. start, finish and percent complete) and submit concurrently with monthly pay request. Monthly update and submittal of the CPM schedule is a prerequisite for processing the Contractor's pay request. The Pay Request submitted must conform to progress reported on the updated CPM schedule.
2. Do not make modifications to the accepted CPM schedule without approval from the Owner. Once CPM schedule is submitted and accepted, identify proposed modifications to activity durations, logic, values or descriptions and submit to Owner in writing. Submittal shall include a proposed revised CPM with the designation "P" preceding the revision number. Submittal shall include all specified reports, graphics and floppy disks except that a time-scaled network diagram shall not be required. Proposed adjustments shall not impact contracted finish date or any required interim milestones.
3. Activity ID numbers and original durations shall not be changed for any activity once accepted by the Owner. Contractor may propose new additional and/or substitute activities for proposed schedule modifications. Contractor may also propose changes of schedule logic for activities previously accepted by the Owner.

## I. Three Week Look Ahead Schedule

1. The Contractor shall prepare a Three-Week Look Ahead Schedule for each bi-weekly meeting showing the items worked the previous week and those scheduled to be in progress during the next three weeks. The activities shall be taken from the accepted Contractor's CPM Construction Schedule and shall include information regarding the following:
  - Impact on the critical path
  - Total float for the included activities
  - Activities expected to be started
  - Activities expected to be completed
2. The Three-Week Look Ahead Schedule shall use a bar chart format and be accompanied by a tabular report of the activities included. The previous week's schedule shall be indicated as a "target" schedule for comparison.

## J. Change Impact Schedule

1. Each Change Order proposal which is anticipated to impact the Critical Path shall include a separate Change Impact Schedule indicating the effect of this change on the accepted Contractor's CPM Construction Schedule.
2. Include a narrative description of the schedule change and a computer generated comparison of the current and the revised schedule.

3. Where appropriate, provide a detailed and quantified analysis of crews, production rates, materials and equipment to support the Change Impact Schedule.

### Final Site Survey

See 01780, Closeout Submittals

## **01500: Temporary Facilities and Controls**

### **01510: Temporary Utilities**

1. See also General Conditions, paragraph 25.
2. The Contractor will be responsible for water and sewage charges on new construction until substantial completion. Show temporary meter(s) on the drawings.
3. The Contractor will be responsible for electrical charges on new construction until substantial completion. Charges should be determined by meter readings. Show temporary meter(s) on the drawings. If a building is to be connected to the GMU electrical distribution system, then a temporary electrical meter should be installed by the Contractor who will be billed monthly. If a building is to be connected to the Public Service electrical system, then the construction Contractor should contact Public Service and pay the bills directly.

### **01560: Temporary Barriers and Enclosures**

#### Construction Fence

Require the Contractor to construct a 6' high chain-link fence around the entire construction area. Specify the Contractor is responsible to erect, maintain and, upon direction by the A/E, remove the fence and restore the area to its original condition. Fence posts shall be installed 3' - 6" into the ground, but need not be set in concrete, except gate posts.

#### Tree and Plant Protection

1. The Contractor while working the site is responsible for protecting all existing trees to remain such that they will be free from any damage. If damage is done, the Contractor shall be responsible for replacement of damaged trees. All trees affected by construction activities shall be protected with snow fencing per the detail in Part IV to the drip line of the tree. Tree replacement and protection is as follows:
2. Tree Protection: contractor shall take all precautions necessary to protect existing trees scheduled to remain against injury or damage, including cutting, breaking, or skinning of roots, trunks or branches; smothering by stockpiled construction materials, excavated materials or vehicular traffic within branch spread.
  - A. Interfering branches of trees scheduled to remain may be removed when acceptable to the University. It cannot be assumed that permission will be



granted. The Contractor must obtain permission from GMU prior to such activities.

- B. Repair trees scheduled to remain and damaged by construction operations in a manner acceptable to GMU. Repair damaged trees promptly to prevent progressive deterioration caused by damage.
3. Tree Replacement: should an existing tree be damaged to the extent that it is deemed to be a complete loss by GMU, or if, due to the Contractor's negligence, a tree on the construction site dies within one year of project completion, the Contractor shall replace the tree according to the following requirements:
  - A. Tree Replacement Formula: One square inch of caliper lost will equal one square inch of caliper replaced. This formula is based on tree trunk diameter at breast height. Example: loss of one 12" caliper (same as 6" radius) tree would require replacement with nine (9) 4" caliper trees. [Area of Circle =  $3.14 \times r^2 = 3.14 \times (6^2) = 3.14 \times (36) = 113.04$  sq. in. Assuming 4" caliper trees (same as 2" radius) will be planted as replacements, calculate the area of a 4" caliper tree:  $3.14 \times (2^2) = 12.56$  sq. in. Divide the area of the 4" caliper tree into the area of the 12" caliper tree to determine the number of 4" caliper trees required to replace the loss of the 12" caliper tree.  $113.04/12.56 = 9$  trees.]
  - B. Installation: Contractor will be responsible for planting the replacement tree(s) at a location designated by GMU. Installation practices and a one year guarantee shall hold as described in Section 02900 - Planting.
  - C. Materials: The replacement tree(s) shall be of the same species and variety as the tree(s) lost. If the species and variety is not available, a substitute must be proposed in writing to the GMU and approved by GMU. The Contractor will be notified of approval of substitution within seven days. Minimum caliper of replacement tree(s) shall be 4".
4. Repair and replacement of trees scheduled to remain and damaged by construction operations or lack of adequate protection during construction operations shall be at Contractor's expense.

## **01700: Execution Requirements**

### **01730: Execution**

#### **Salvaged Materials and Equipment**

For renovations and demolition, insure the title to existing materials and equipment of value is specified.

### **01780: Closeout Submittals**

#### **Operation and Maintenance Manuals (O&Ms)**

1. As applicable, for each specification section under "Submittals", include "Operation and Maintenance Data: Submit information for all products in accordance with the requirements of Specification Section 01330 and 01780".

## 2. Submittal Schedule

- A. Before Substantial Completion, submit 2 draft copies for review. Include a complete index or table of contents of each manual. One copy will be returned with comments within 21 days of receipt.
- B. Provide two sets of O&Ms at Final Inspection

## 3. Format / Organization

- A. Provide material in stiff-backed, 3-ring binders sized to receive 8 ½” x 11” paper. Correlate data in each binder by division. Provide a tab for each specification section used in the project. The tab shall identify the specification section number and title.
- B. Identify each binder on front and spine with the printed title, “Operation and Maintenance Manual,” project title, project number, division number and division title. Where two or more binders are necessary to accommodate data, use the following manual organization:

|          |      |               |
|----------|------|---------------|
| Division | 1-14 | Architectural |
| Division | 15A  | Mechanical    |
| Division | 15B  | HVAC Controls |
| Division | 16   | Electrical    |

## 4. Manual Content

Each manual shall include, but not be limited to, the following:

- A. General system or equipment description, including operation and control sequencing narrative.
- B. Design factors and assumptions.
- C. Names, addresses and trades of all applicable subcontractors, manufacturers and suppliers who participated in the construction or who furnished materials and equipment.
- D. Copies of applicable shop drawings and product data.
- E. System or equipment identification, including:
  - (1) Name of manufacturer
  - (2) Model number
  - (3) Serial number of each component
- F. Operating instructions including starting and stopping.

- G. Emergency instructions.
- H. Detailed one-line, color-coded wiring diagrams.
- I. Inspection and test procedures.
- J. Preventive maintenance procedures and schedules.
- K. Precautions against improper use and maintenance.
- L. Copy of warranties.
- M. Repair instructions including spare parts listing.
- N. Sources of required maintenance materials and related services including spare parts lists and list of most frequently encountered breakdowns and repairs.
- O. Manual index.
- P. Detailed catalog data.

### Warranties

#### 1. Submittal Schedule

At final inspection, provide two sets of all warranties in addition to the copy required in the Operation and Maintenance manuals.

#### 2. Format / Organization

A. Provide warranties in stiff-backed, 3-ring binders sized to receive 8 ½” x 11” paper. Correlate data in each binder by division. Provide a tab for each specification section used in the project. The tab shall identify the specification section number and title.

B. Identify each binder on front and spine with the printed title, “Warranties,” project title, and project number.

#### 3. Content

Each warranty shall indicate:

A. Project Title

B. Project Number

C. George Mason University as the Owner

- D. Specification Section
  - E. Product Description
  - F. Warranty start date that equals the Final Completion date. If GMU takes occupancy before final completion, the warranty start date equals the occupancy date.
  - G. Name of company
  - H. Address of company.
  - I. Telephone number of company.
  - J. Name of point of contact
4. When specifying warranty length, confirm availability.

**Spare Parts and Maintenance Materials**

1. A list of spare parts and maintenance materials to be turned over by the Contractor at completion shall be developed by the A/E. These items shall include, but not be limited to, labeled keys, spare fuses, belts, filters (in addition to a new set installed at completion), ceiling tile, VCT floor tile, carpeting, paint for touch-ups, and spare light bulbs.
2. In general, spare parts should be specified for maintenance/minor repair items that would need to be replaced quickly to keep the building system operational (then restocked later), and items very specific to the project such as finishes. Some items specified in the past follow, but the A/E should make adjustments to the list based on applicability and experience:
  - a. Tile: 3% of each type
  - b. Resilient floor tile: 1 box for each 50 boxes installed
  - c. Resilient wall base: 10 ft. for each 500 ft. installed
  - d. Acoustical ceiling panel: 2%
  - e. Acoustical ceiling panel components: 2% of exposed components
  - f. Carpet: 5%, but not less than 10 yd<sup>2</sup>
  - g. Paint: 5 gallons of each color.
  - h. Diagnostic tools for elevator microprocessor control system
  - i. Heat exchangers: one spare gasket for each flanged connection for each heat exchanger
  - j. Fans: one additional complete set of belts for each belt-driven fan
  - k. Air filters: one complete extra set of filters for each filter bank. If system includes prefilters and afterfilters, provide only prefilters
  - l. Variable volume Air Handling Unit: one set of filters for each fan
  - m. Duct accessories: 10% of fusible links installed
    - Control valves for room Fan Coil Units: 10 two-way, 5 three-way

- Digital damper actuators for make-up Air Handling Units: 2
  - Pump seals: one set for type of pump installed
- n. Switchboards: 20% spare fuses (3 min., 9 max.) of all sizes
  - o. Wiring devices: 1 of each type for every 25 installed, but not less than 1
  - p. Cover plates: 1 of each type for every 25 installed, but not less than 1
  - q. Lamps: 10% of amount installed
  - r. Ballasts: 1 of each type for each 25 installed
  - s. Telephone/data cable: 250' of each size and type installed
  - t. Telephone/data outlet assemblies: 1 of each type for every 25 installed, but not less than 1
  - u. Fire Alarm:
    - Lamps for Remote Indicating Lamp Units: 10%, but not < 1
    - Lamps for strobe units: 10%, but not < 1
    - Smoke, fire, flame detectors: 10%, but not < 1
    - Detector bases: 2%, but not < 1
    - Printer ribbons: 6
    - Keys and tools: one extra set for access to locked components
3. Insure quantity of spare parts is realistic for amount installed.
  4. An inventory and sign-off of material received and accepted by the University shall be developed by the Contractor. All construction materials not accepted by the University shall be removed from the site by the contractor.

### Final Site Survey

Require that the General Contractor engage the services of a Virginia licensed land surveyor to locate and record all underground utilities installed as part of each contract. Survey shall show exact route of each utility invert or depth of cover and connection points to existing utilities. Identify, locate and dimension off of above-ground permanent improvements all manholes, catch basins, valve boxes or other structures.

## **01800: Facility Operation**

### **01810: Commissioning**

1. Commissioning shall address verification that systems are installed per specifications and industry standards; that start-up procedures and testing are properly conducted and documented; that receipt of proper as-built drawings, operation and maintenance manuals, required spare parts, certificates and warranties are provided to the Owner; and that Owner's personnel receive useful training on the installed systems. The Architect/Engineer should arrange the specifications to cover these items within the specific section. For commissioning of HVAC systems, see also the Construction and Professional Services Manual, Section 816.0.

2. The A/E shall include a list of closeout requirements in the specifications. In addition to the items above, these shall include witnessed system start-ups and demonstrations, quantities and service provisions for one year from building acceptance for elevators, mechanical systems, air balancing, door adjustments, faulty lighting replacements and dead tree and plantings replacement. HVAC systems are to be demonstrated and signed off while operating in both heating and cooling modes under actual load conditions. As an example, for buildings accepted during the winter months proper operation of both the heating and cooling system shall be demonstrated, but a later demonstration of the cooling system shall be performed by the contractor when the cooling season starts. If accepted during cooling season, the building shall again be demonstrated to operate properly in the first heating season following completion and acceptance.
3. The purpose of the commissioning process is to provide the Owner assurance that systems have been installed in the prescribed manner and will operate within the performance guidelines. Commissioning is intended to enhance the quality of system start-up and aid in the orderly transfer of systems to beneficial use by the Owner.
4. The Contractor verifies installation, provides scheduling and coordination of commissioning activities, performs training, starts-up equipment, conducts functional performance testing, corrects deficiencies, performs retests, and provides documentation of the process.
5. Commissioning procedures and results will be observed by the Owner's designated witnesses (Commissioning Agent and/or Owner's staff). The Contractor is expected to verify the functional readiness of systems to be tested prior to performing the tests in the presence of the Owner's witness(es). A high rate of failure will indicate that the Contractor has not adequately verified the readiness of the systems.
6. The requirement for a Start-up Plan, Testing, Adjusting, and Balancing Plan, and Functional Performance Test Plan, shall be specified in the specific section for each piece of equipment or system that is to be commissioned.
7. Problems observed during commissioning shall be addressed immediately, in terms of notification to responsible parties, and actions to correct deficiencies.
8. Operations and Maintenance Manuals: see 01780.

### Commissioning Plan

Develop a commissioning plan to identify how commissioning activities will be integrated into general construction and trade activities. The plan is the key means for the Test Engineer to inform all parties as to how each system functions, independently and with respect to other systems. The plan shall be updated regularly and redistributed to the commissioning team for review and comment. The intent of the plan is to evoke questions, expose issues, and resolve them with input from the entire commissioning team early in construction. The commissioning plan shall identify how commissioning responsibilities are distributed, and:

- a. Be submitted in accordance with the General Conditions within 90 calendar days of Notice to Proceed.
- b. Include an organizational chart identifying key General Contractor positions and key subcontractors. Include lines of communication and authority.
- c. Identify who will be responsible for producing the various procedures, reports, Owner notifications and forms required in the specifications.
- d. Describe the test/acceptance procedure.
- e. Identify which subcontractors will participate in each of the tests.
- f. Identify instrumentation required for each test.
- g. Identify who will provide instrumentation for each test.
- h. Include an Operational Description: This shall include, for example, the design criteria, design intent, code requirements, specifics of the equipment to be provided, sequences of operation, operating priorities, protocols, etc.
- i. Include the Commissioning Schedule
  - 1) Integrate start-up activities, testing and balancing activities, and functional performance testing activities into the Critical Path Method (CPM) master construction schedule. Commissioning scheduling is the responsibility of the Contractor.
  - 2) Prior to beginning of start-up, testing and balancing, or functional performance testing activities, update the schedule of commissioning activities monthly.
  - 3) Two weeks prior to the beginning of a start-up, testing and balancing, or functional performance testing activity, provide a detailed two-week look-ahead schedule. Thereafter, update the two-week look-ahead schedule weekly for the duration of commissioning for that construction phase. The two-week look-ahead schedule shall identify the date, time, beginning location, Contractor personnel required, and anticipated duration for each start-up, testing and balancing, or functional performance test activity.
- j. Include a Start-up Plan, consisting of the following, for each piece of equipment or system that formal start-up is specified
  - 1) Start-up Schedule
  - 2) Names of firms/individuals required to participate
  - 3) Detailed start-up procedures: These procedures will be reviewed for technical depth, clarity of documentation and completeness.

- 4) Start-up data forms
- k. Include a Test Equipment Identification List, consisting of the following, for each instrument, sorted according to intended use.
  - 1) Manufacturer
  - 2) Model Number
  - 3) Serial Number
  - 4) Calibration Certification
  - 5) Range
  - 6) Accuracy
  - 7) Resolution
  - 8) Intended Use
- l. Include a Testing, Adjusting, and Balancing Plan in accordance with 15950, and consisting of the following
  - 1) Testing, Adjusting, and Balancing Schedule
  - 2) Testing, Adjusting and Balancing (TAB) Data Forms
  - 3) Testing, Adjusting and Balancing (TAB) Procedures
  - 4) Testing, Adjusting, and Balancing (TAB) Report
- m. Include a Functional Performance Test Plan consisting of the following:
  - 1) Functional Performance Test (FPT) Procedures
    - a) Each procedure shall have a unique alpha-numeric designator.
    - b) The same procedure may be applied to multiple identical pieces of equipment or systems.
    - c) Procedures shall reference the applicable specification section upon which the procedure is based.
    - d) Procedures will be reviewed for technical depth, clarity of documentation, compliance with “Acceptance Criteria: specified elsewhere, and completeness.
    - e) Identify the value for all setpoints and inputs, positions of adjustable devices, valves, dampers and switches.
    - f) Identify the range of acceptable results for each condition tested. As an example, if field verification with the contractor’s air balancing firm reveals a variance of more than +/-10% of stated TAB report values on up to 25% of the boxes tested, than the entire TAB report shall be rejected and the entire building re-balanced.



- g) FPT procedures shall be detailed test instructions, written with sufficient step-by-step information to allow a test to be repeated under identical conditions with repeatable results.

2) Functional Performance Test (FPT) Data Forms

- a) Identify each FPT test data form by a unique designator and a suffix to identify multiple repetitions of the same procedure.
- b) Include space to record:
  - I. Description of the procedure
  - II. Whether the form is for a retest of a failed procedure
  - III. Identification and location of the equipment being tested
  - IV. Identification of instrumentation used, by serial number
  - V. Observed conditions at each step of the procedure
  - VI. "Acceptable Results" as specified elsewhere
  - VII. Date of test
  - VIII. Names of technicians performing the procedure
  - IX. Name and signature of the Test Engineer
  - X. Name and signature of the Commissioning Agent or Owner-designated witness. Signature of witness shall only indicate concurrence with reported results and observations. Acceptance of results will be reported separately after review of the FPT data forms by the Architect and Commissioning Agent.

3) Functional Performance Test (FPT) Deficiency Report Forms. Include space to record:

- a) Associated FPT test data form number
- b) Date of test
- c) Name of person reporting the deficiency
- d) Description of the observations associated with the failure of the test
- e) Cause of the failure, if apparent at the time of the test
- f) Date and description of corrective action taken
- g) Name and signature of person taking corrective action
- h) Schedule for retest

**01820: Demonstration and Training**

Specify all training to be performed on site.

**End of Section**

## **Division 2: Site Construction**

### **02050: Basic Site Materials and Methods**

#### **02080: Utility Materials**

Hydrants shall be as manufactured by Mueller or as approved by Owner. Generally use National Standard hose threads but A/E shall verify.

#### **02200: Site Preparation**

The Contractor shall give notification to the appropriate Soil Conservation district, 3 days prior to start of work on the site.

#### **02220: Site Demolition**

1. When a building/facility is to be demolished, without new construction in its place, all foundation walls shall be removed to a point 3'-0" below grade. All basement slabs below the 3'-0" level need not be demolished, but must be broken into approximately 4' square areas or less to allow drainage of water. Require the Contractor to hire the services of a Virginia licensed surveyor to document the location of all foundations left in place below the 3'-0" location, as well as abandoned utilities, and utilities relocated as required by the demolition work. Survey shall become part of the as-built drawing requirements of the Contractor at completion of the work.
2. All demolition debris shall be removed from the University property and disposed of by lawful means. Backfill of buildings shall be with clean fill, compacted to at least 95% minimum density for cohesive material and 95% relative density for cohesionless material. Area shall be topsoiled and seeded.
3. University approval must be obtained prior to any demolition of basement floors, or before making connections into old underground waste systems.
4. All utilities shall be cut and capped. The location of the preceding cuts/ caps shall be annotated on the as-built survey provided by the Contractor.

#### **02230: Site Clearing**

Topsoil shall be stripped to the depth determined by the Soils Engineer, usually not less than 4". Topsoil shall be stockpiled in accordance with the requirements of the Soil Conservation District in locations as directed by the A/E, or elsewhere on University property. Under no circumstances shall topsoil be removed from University property. Topsoils shall not be mixed with subsoils or other site debris.

## **02300: Earthwork**

### **02315: Excavation and Fill**

1. All excavation for GMU projects shall be unclassified excavation, meaning that whatever material is encountered during excavation must be removed. If the soils reports indicate large quantities of rock at the elevations of the building footings, this procedure may be modified, with the permission of the University. The Contractor shall be instructed to stop excavation if anything of archaeological value is encountered. Please contact Miss Utility prior to excavation.
2. Require the Contractor to hire a Soils Engineer approved by the A/E to perform inspection and testing of all earthwork. Soils Engineer shall be a Professional Engineer licensed in the Commonwealth of Virginia and possess professional liability insurance in the minimum amount of \$500,000. Soils Engineer shall provide all field and laboratory services required to:
  - A. Test and evaluate all samples of proposed fill materials to determine optimum moisture density relationship in accordance with ASTM D 1557.
  - B. Test all samples to assure compliance with gradation requirements of this Specification. Grain size analysis shall be performed in accordance with ASTM D 422.
  - C. Determine depth of topsoil stripping. Existing site topsoil shall be reviewed to determine the need for importing offsite topsoil for use in final landscaping. Existing university topsoil has not produced desired finished lawns around new facilities.
  - D. Inspect all proof rolling and determine the presence of any local soft pockets.
  - E. Inspect excavation in natural soil to determine if bearing stratum meets design criteria.
  - F. Inspect and test compacted fill to determine compliance with these Specifications. Field densities shall be determined by ASTM D 1556M, ASTM D 2167 or ASTM D 2922.
  - G. Keep written records of all tests and field instructions, and summaries of these reports shall be mailed weekly to A/E, University, University Code Official, and Contractor. Final written summaries shall be provided upon completion of work.

### **02500: Utility Services**

Underground steel pipe systems shall be cathodically protected using Pikotec or approved equal.

## **Pipeline Marker**

1. All underground piping runs, both mechanical and plumbing shall be protected with buried pipeline marker. Marker to be 6 mil thick, 3" wide, florescent yellow polyethylene. Tape to be imprinted to read "Caution- buried pipe below".
2. Tape to be placed 1' 0" directly above top of pipe, over entire length of run.
3. Tape to be placed on top of 4" deep x 6" wide layer of clean white sand.
4. Any existing tape which is encountered, removed or disturbed during excavation shall be replaced in conformance with items no 1-3 above and to the approval of Rutgers, prior to backfilling.

## **02510: Water Distribution**

1. Major water mains shall be ductile iron, cement lined, mechanical joint with thrust or rod as necessary. Cover exterior pipes per Factory Mutual requirements (or minimum 3'-6").
2. Reference Standards: Installation of underground fire protection mains shall comply with the following standards:
  - A. NFPA No. 24, Private Fire Service Mains and their Appurtenances
  - B. Factory Mutual Data sheet 3-10, Fire Service Mains
3. Piping: Shall be listed for fire protection service and comply with AWWA standards. Underground mains shall be cement lined ductile iron.
4. Depth of Cover: The depth of cover over fire protection water mains shall be not less than 4 1/2 feet, measured from the top of the pipe to finished grade.
5. Pipe Joints: All bolted joint assemblies shall be cleaned and thoroughly coated with asphalt or other corrosion-retardant material after installation of the assembly and prior to inspection and backfilling.
6. Anchoring: Mechanical joints shall be utilized on all tees, plugs, hydrant branches and bends. These joints on underground pipe shall be restrained against movement. Restraint shall be via thrust blocks, and/or rods and clamps.
7. Thrust Blocks: Thrust blocks shall be provided at all tees, plugs, caps, bends and hydrants and shall be of concrete mix having not less than 2,000 psi strength at 28 days. Thrust blocks shall be poured between the underground pipe and undisturbed earth, leaving the pipe joint accessible for inspection and repair, and not obstructing the fire hydrant drain ports. Thrust blocks shall be sized in accordance with table 8-6.2.7 of NFPA-24.

8. Flushing: Underground mains and lead-in connections to system risers shall be flushed thoroughly before connection is made to sprinkler, standpipe, or other fire protection system piping in order to remove foreign materials which may have entered the pipe during the course of the installation. The minimum rate of flow shall be not less than the demand rate of the system or the following rates, which ever is the greater:

| Pipe Size | Flow Rate |
|-----------|-----------|
| 4"        | 400 gpm   |
| 5"        | 600 gpm   |
| 6"        | 750 gpm   |
| 8"        | 1000 gpm  |

9. Fire Hydrant: The hydrant shall contain one 4-1/2" National Standard Fire Hose Thread (NST) pumper outlet and two 2-1/2" NST hose outlets. The pumper outlet shall be adjusted to face in the direction prescribed by the University, and such adjustment, if necessary, shall be made by the installing contractor prior to acceptance of the installation by the University.
- A. All fire hydrants shall be set on a gravel bed of at least 12" deep, minimum to ensure quick drainage from the ports provided near the base of the hydrant barrel.
- B. The center of the pumper connection shall be not less than 12" above final grade.
10. Inspections and Tests: No underground fire protection pipe assembly or fire hydrant shall be backfilled prior to inspection and approval of the installation by the University.
- A. A hydrostatic test shall be performed on the underground fire protection pipe assembly upon completion of the installation. All components, such as valves, fittings, hydrants, etc. shall be installed prior to the final test. The Contractor may conduct preliminary testing for his benefit, however the University will not accept such preliminary testing in lieu of the final required inspections and tests. The hydrostatic test shall be performed for not less that two hours, and shall be witnessed by the University.
- B. A contractor's material and test certificate for Underground Pipe shall be completed and submitted, by the Contractor, to Factory Mutual Engineering and the University on an approved form. The contractor shall provide a hydraulic design placard at the main riser base.
11. The contractor will be required to provide water meters per Fairfax County specifications. See 15120.

## **02530: Sanitary Sewerage**

Minimum cover under roads for Sanitary Sewer systems shall be 3'-6" and minimum slope shall be 1" in 15'-0" (.55% slope).

## **02550: Piped Energy Distribution**

See High Temperature Hot Water Tunnel clearance detail in [Part V – Standard Details](#).

## **02580: Electrical and Communication Structures**

1. Underground ductbank runs shall be installed minimum of 30" below grade to top of bank, wherever possible. If 30" is not possible, concrete encased ducts may be installed to minimum burial depth stipulated in NEC. Underground runs cable markers shall be installed for all direct-buried cables and cables in non-metallic and metallic raceways. Marker shall be located directly over buried lines at 8 to 10 inches below finished grade. Marker tape shall be standard metallic lined, permanent, bright red colored continuous printed plastic tape for direct burial service, not less than 6 inches wide by 4 mils thick, and printed, "caution electric line buried below."
2. Service runs from existing manholes and/or buildings to new buildings shall be run in duct banks. Duct banks shall use 4" minimum PVC schedule 40 ducts supported on approved spacers and encased in red concrete, and located a minimum of 30" below grade to top of bank. Runs under traffic areas shall be reinforced. Duct bank runs shall be no greater than 300 feet long, unless otherwise approved, and run into manholes as needed to serve the facility.
3. Service runs to outdoor or indoor building unit substations shall be underground conduits two 4" schedule 40 PVC runs minimum; use four 4" PVC if for loop feed service; and encase in red concrete. Low voltage service runs to buildings shall be sized per load being served and shall include a minimum of 2 spare ducts.
4. Duct run terminations shall be made using rigid galvanized steel conduit. Slope duct runs into manholes to drain, and runs shall be essentially straight between manholes. Ducts shall be run below gas lines, and where ducts cross high temperature water lines a minimum separation of 3 feet shall be maintained, and a minimum of 6" thick foamglass type insulation extending at least 4 feet in both directions of crossing shall be used.
5. Electric Manholes:
  - a. Construction: Electric manholes shall be a minimum of 6 feet square and 7 feet deep at the inside dimensions. Hardware shall include pulling eyes and inserts, and cable racks. Concrete 4000 psi at 28 days, with re-bar reinforcement. Precast manholes are preferred.

- b. Drains: Manholes shall be provided with a drain to the storm sewer that will not backwash shall have a sump cast into the floor next to the ladder into which a portable sump pump can be installed. Floor shall slope to sump.
- c. Covers: Manhole covers shall be round, having a standard manhole frame and cover. The cover shall be 30" in diameter and have the word ELECTRIC or TELEPHONE cast into it. Install frame and cover assembly on at least 4 courses of brick or precast concrete rings to allow adjustments to surrounding finish grade. Manholes shall be labeled as confined spaces.
- d. Ground: A copperweld ground rod shall be installed in each manhole for bonding of hardware and cable sheaths.

### Telecommunications Service Entrance

1. Identify communications manhole to be used on the building plans. Telecommunications Staff will specify. Provide new manhole and underground path to the building if the existing manhole is not available. Distance between manholes should not exceed 600'. The total number of bends in a conduit run shall not exceed two 90° bends or equivalent of sweeps and radius bends. Each bend will have a minimum radius in accordance with existing standards (10 times the I.D. minimum for the bend radius).
2. Install four (4) - Four (4) inch diameter polyvinyl chloride PVC schedule 40 conduits from existing and/or new manholes to the building shear line. The conduits will be installed at a minimum depth of 30" and backfilled with select material. An orange warning tape will be placed in conduit trench approximately 12" below the surface. Encase conduits in concrete (2,500 PSI), except when terminating at a pole. When terminating at a pole, clamp the conduit(s) rigidly to the field side of the pole at a 90° separation from power.
3. Galvanized steel conduits should be used from the inside of the, building to undisturbed earth to Prevent a "shearing point" at the building edge. Conduits terminating inside a building will be installed so that the conduit extends four (4) inches beyond the surface from which it emanates. Conduits shall be plugged with inserts to ensure that foreign matter does not enter the building. The ends of metallic conduit shall be reamed, bushed and grounded according to the National Electric Code. All conduits are to be installed with a minimum 200 lb. test noncorrosive graduated pull tape.

(\* Minimize routing of conduits under the building foundation.)

4. Provide and install the 6'W X 12'L X 7'D in-line manholes allowing two splicing bays and 7'W X 9'L X 7'D auxiliary manholes as needed. Prefabricated manholes preferred whenever possible. Manholes should be equipped with cable racks, pulling irons, 8" sump hole, frame, cover and ladder. A 6'-6" galvanized straight steel ladder is required when the chimney height is 12 inches or less. When the chimney height is 12 inches or more, a hooked ladder is required and manhole steps are to be provided at 12 inch intervals. The frame shall have a

nominal opening of 27 inches and the cover is to be marked with a "C"; "Communications", or "T"; "Telephone".

5. Terminating Space for the service entrance shall have a 3/4' trade size A-C plywood. 8 ft. High X 4' Wide. The terminating space shall include a two 110 V, 20 -amp AC Power outlets and lighting equivalent to 50 foot-candles 3 feet above the floor. A #6 ground should be provided at the terminating space.

## **02600: Drainage and Containment**

### **02630: Storm Drainage**

1. Trench type storm drains are to be avoided.
2. Road grates shall be Campbell Foundry Company #2617, or approved equal. These grates are bicycle safe grates.
3. The top of lawn grates shall be set 1/2" below finished grade level to facilitate drainage. Lawn grates shall be round.
4. Specify that Contractor shall clean interior of piping after installation.
5. Manholes: Specify precast concrete, 4000 psi minimum with rubber gasket joints. Wall to be 5" thick with aluminum drop front ladder rungs, 12" o.c. Base, as a minimum, shall be 6" thick with #4 bars 12" o. c. both ways. Manhole openings shall be 30" diameter with roadway type frame and cover by Campbell or Neenah Foundries, or approved equal. Entire interior concrete surface shall receive 2 coats "Drycon" as manufactured by I. P. A. Systems, Inc.

### **02670: Paving Specialties**

#### *Parking Space Marking*

Non-handicap parking stalls shall normally be 8'-6" wide and 18'-0" deep with a 22'-0" aisle. Stall line markings shall be 4" wide single line, white color. If required include directional arrows in the contract.

## **02700: Bases, Pavements, and Appurtenances**

### **02740: Flexible Pavement**

1. All asphalt pavements shall conform to the following minimum thickness for the use intended as noted below. The subgrade bearing capacity should be determined by tests. Require the Contractor to remove any areas not meeting the required bearing capacity which he may encounter during subgrade preparation. Those areas will be filled and compacted with suitable material to achieve the required CBR. During preparation of the subgrade, specify that



the Contractor perform CBR tests as necessary, but in no case less than one test for each 1000 S. Y. of paved area.

| VALUE PAVEMENT TYPE   | MIN. CBR TYPE | TYPE & THICKNESS OF BASE COURSE                   | TYPE & THICKNESS OF SURFACE COURSE |
|---|---------------|---|------------------------------------|
| TYPE A<br>Sidewalks, play areas,<br>bike paths, bus stops                                 | 10            | Mix I-4, 4"<br>Surface to be as tight as possible | Single Lift                        |
| Type B<br>Driveway which carries<br>only passenger cars and<br>passenger car parking lots | 10            | Mix I-2, 4"                                       | Mix I-5, 1-1/2"                    |
| Type C<br>Local roads which carry<br>passenger cars and light<br>trucks                   | 10            | Mix I-2, 4-1/2"                                   | Mix I-5, 1-1/2"                    |
| Type D<br>Feeder roads which carry<br>bus & truck traffic and bus<br>& truck parking lots | 10            | Mix I-2, 5"                                       | Mix I-5, 2"                        |
| Type E *<br>Arterial roads and service<br>roads with heavy truck &<br>bus traffic         | 10            | Mix I-2, 6"                                       | Mix I-5, 2"                        |
| Type F<br>Heavy duty bus & truck<br>roads and service drives                              | 10            | Mix I-2, 7"                                       | Mix I-5, 2"                        |

\* Shall also include all sidewalks used for service and emergency vehicular access.

2. Fire lanes shall be a minimum of 18' wide.

### **02770: Curbs and Gutters**

Concrete curbs shall be formed of minimum 4000 psi concrete.

### **02775: Sidewalks**

1. In general all permanent sidewalks shall be cast-in-place concrete. If temporary walkways are required, they may be asphalt. Concrete will not be accepted if graffiti is present. Concrete with graffiti shall be removed by the Contractor and replaced at Contractor's expense.

2. GMU's standard sidewalk is minimum 6' wide, 6" slab constructed of 3000 psi 4 – 6% air entrained concrete reinforced with 6 x 6 #10 welded plain cold drawn steel flat panel wire mesh, with broom finish. Wire mesh shall be supported by, and attached to, 3" rebar chairs that are spaced adequately to ensure support of the mesh during the concrete pour. A 6mil. vapor barrier shall be used on compacted base of naturally or artificially graded mixture of natural or crushed gravel, crushed stone, crushed slag, natural or crushed sand. Aggregate used within the sidewalk shall be rounded.
3. Install 6'-minimum turning radius at all sidewalk intersections for electric carts.
4. Install ramps where sidewalks intersect roads for electric cart access.
5. Transverse control joints shall occur 6' - 0" on center for 6' - 0" wide sidewalks. Transverse contraction joints with premolded joint fillers shall occur 48' - 0" on center. Premolded joint fillers shall be 1/2" thick asphalt impregnated fiber board conforming to ASTM C 1751 and caulked with an appropriate type for this application. Control joints shall be made with tools that provide slightly curved edges and no flats on the surface of the sidewalk.
6. Consider using non-slip finish on sidewalks, steps, and metal grates where a slipping hazard may exist.

## **02800: Site Improvements and Amenities**

### **02810: Irrigation System**

1. All new buildings shall be prepared for irrigation systems whether these systems are part of the project or not. Systems shall be vandal-proof and include programmable boxes and rain meters. Sprinkler heads shall be "pop-up" type that fully retract when not in use. The system must also possess a drain valve(s) so the system can be flushed or drained using air pressure. Preparation shall include a location within an appropriate Mechanical or Electrical Equipment Room for a controller, with a designated circuit breaker, and an empty 1" conduit with pull rope to a point 5' outside the building, 3' - 0" below grade, with shutoff valve inside the building in an accessible location. Regardless of the system being installed, a backflow preventer must be installed as part of irrigation system under the building contract.
2. New buildings shall also be provided with outside water access. Turn-on valves must fit a standard four way universal water key with hose connections sized for a standard garden hose.
3. Where down spouts are utilized, these should be tied into adjacent storm drainage.

### **02820: Fences and Gates**

Fencing is required around all climbing hazards and grade installed mechanical and electrical equipment (i.e. cooling towers, emergency generators, etc.).

## **02840: Walk, Road, and Parking Appurtenances**

Bollards shall be installed wherever the need exists to prevent non-university vehicles from entering authorized areas or to prevent vehicular traffic onto sidewalks.

## **02870: Site Furnishings**

### *Bicycle Racks*

Standard bicycle rack is The Ribbon ® Rack by AAA Ribbon ® Rack Co. ( [www.ribbonrack.com](http://www.ribbonrack.com) ). See Part V for standard details. Dark green color Dupont 7498, size capacity as required.

### *Benches*

1. George Mason University has adopted the following standard benches for use on the campuses noted. See Part V, Standard Details.

#### Fairfax Campus

Manufacturer: Custom Structures, Inc.  
Model: P18S (Pullman Series w/o back)

#### Arlington Campus

Manufacturer: Victor Stanley, Inc.  
Model: The “Dunkirk”

#### Prince William Campus

Manufacturer: Custom Structures, Inc.  
Model: P18S (Pullman Series w/o back)

2. All benches shall be placed on hard surfaces (concrete walks, plazas, etc.).

### *Waste Receptacles*

All exterior site receptacles shall be as follows:

1. Trash Receptacles

#### All Campuses:

Manufacturer: Victor Stanley  
Model: S-42, Ironsites – Bethesda Series or equal 36 gallon litter receptacle with 3/8” solid steel bars standard tapered spun-steel lid, 36 gal high density plastic liner, vs green color. See Part V, Standard Details.

#### Parking Lots:

Manufacturer: Parkside receptacles or equal  
 Model: Landscape series, WR-34 with security chain, green

2. Snuffers (Cigarette urns)

All Campuses

Manufacturer: Provided by GMU.

Model:

**02900: Planting**

Provide a Planting Schedule that specifies the types, number, and sizes of plants and trees.

**02910: Plant Preparation**

Subgrade

Preparation of Subgrade: Specify that subsoil shall be loosened to a depth of 5” and graded to remove all ridges and depressions so that it will be parallel to proposed finished grade. Remove stones over 1” in any dimension, sticks, rubbish and other extraneous matter.

Topsoil

Specify that all topsoil shall be tested against the following Specifications:

Physical Analysis (Soil Texture)

| Quantity<br>Percent by oven dry weight | Size Fraction<br>inches | Range of Particle Diameter<br>mm |
|--|-------------------------|----------------------------------|
| Less than 2% gravel                    | larger than 1           | 25                               |
| Less than 3% gravel                    | 1/4 to 1                | 6-25                             |
| Less than 10% gravel                   | 2/25 to 1/4             | 2-6                              |
| 40% to 65% sand                        | 1/500 to 2/25           | .05-2.0                          |
| 25% to 60% silt                        | 1/12,500 to 1/500       | .002-.05                         |
| Less than 20% clay                     | small than 1/12,500     | .002                             |

- Amounts of sand, silt, and clay - determined by official hydrometer method or mechanical analysis of the soil. Gravel sized particles should be determined by separation on screens with appropriate size openings.
- Soil should be relatively free of under composed organic material like roots, sticks, leaves and paper and of any other undesirable trash like glass, plastic or metal fragments that would have to be removed before seeding or planting.

Chemical Analysis

- Organic matter content (% oven dry weight of soil): sandy loam 1.25% to 20%, Loam and Silt Loam 2.5% to 20%
- On soil with less than 10% organic matter, use wet oxidation method of analysis. On soil with more than 10% organic matter, use loss on ignition method of analysis.
- Soil reaction - pH of 4.5 to 7.0
- Soluble salt content: conductivity (ECe, milliohms per centimeter),
  - Less than 1.00 mmhos/cm for a 1:1 soil: water ratio,
  - Less than 0.50 mmhos/cm for a 1:2 soil: water ratio,
  - Less than 0.33 mmhos/cm for a 1:3 soil: water ratio

### **02920: Lawns and Grasses**

1. All new lawns and plantings shall have an underground irrigation system. See Section 02810.
2. Sod is preferred over seed, especially near building perimeters. Sod is always to be used in interior courtyards. Decision as to the use of seed or sod will be a budgetary decision. Hydroseeding is not preferred. GMU will indicate the type of lawn treatment that will prevail.
3. Preferred sod shall be turf type tall fescue. Sod should be ½”-1” thick Rolled sod is acceptable upon approval of the Project Manager.
4. All new lawn areas sodded or seeded shall have the entire perimeter staked and roped off immediately upon completion. Stakes shall be no less than 30” high installed and string banner shall be two strands stake to stake. After turf establishment (2-3 weeks), watering and regular mowing is required by the contractor for 60 days beyond establishment of turf, and a 6 month final inspection of the turf shall be conducted at which the time areas requiring additional treatment at the contractor’s expense will be identified.
5. Straw Mulching: salt hay with nonasphaltic liquid tackifier is preferred. For finished grades having slopes in excess of 20% shall be mulched with erosion control fabric run vertically from top to bottom of slope and stapled with wire staples .125” in diameter or greater and spaced at 4’ intervals. In areas of high velocity runoff such as receiving swales and drainage ditches fabric of sufficient strength and density shall be used and installed in direction of flow and stapled at 2’ intervals.

#### Seed Mixtures

AOSCA (Association of Seed Certification Agencies) certified seed. Sowed at a rate of 4-5 lbs/1,000 square feet.

- Full Sun Mixture:            50% Kentucky Bluegrass  
   10% Perennial Ryegrass  
   10% Perennial Ryegrass  
   15% Chewings Fescue  
   15% Creeping Red Fescue
  
- Shade Mixture:                30% Chewing Fescue  
   15% Creeping Red Fescue  
   30% Kentucky Bluegrass  
   35% Hard Fescue
  
- Tri-Plex Rye Mixture:       33.3% Perennial Ryegrass  
   33.3% Perennial Ryegrass  
   33.3% Perennial Ryegrass
  
- Drought Mixture:            90% Turf-type Tall Fescue  
   10% Kentucky Bluegrass

**Inspections**

1. Inspections will be made at completion of the following tasks:
  - A. At completion of the soil loosening phase to insure that the minimum depths have been achieved.
  - B. At completion of the removals and /or screening phase to insure that specified dimension material has been removed.
  - C. At completion of the top soiling phase to insure that full depth of cover has been achieved.
  - D. At completion of the fine grading phase to insure that specified slopes, uniformity and positive drainage have been achieved.
  - E. At completion of the seeding and mulching phase to insure adequate coverage.
  - F. At the end of the 60 Day Maintenance Period to insure adequate percentage of growth and coverage as specified has been achieved.
  
2. It is the responsibility of the Contractor to notify the Project Manager of the completion of each task in writing for approvals prior to proceeding to the next phase. Unsatisfactory conditions must be corrected at Contractor's expense before beginning next phase tasks.

**02930: Exterior Plants**

**Warranty**

1. Specify that the Contractor shall guarantee newly installed plants for a period of one year after date of acceptance against defects, including death and unsatisfactory growth. Trees which are not healthy, dying, or the design value of

which, in the opinion of the A/E or GMU, has been destroyed through root damage, loss of branches, bark damage, etc. shall be replaced by the Contractor at no cost to the Owner. Exceptions are defects resulting from abuse or damage by others, or unusual phenomena or incidents which are beyond landscape installer's control.

2. Specify that plants which are determined to be defective shall be replaced at the proper season or planting time after the guarantee period is complete and replacement plants will be guaranteed by the Contractor for an additional growing season under an extended guarantee at no additional cost.
3. Specify that, during the guarantee period, the Contractor shall, from time to time, inspect the watering and other maintenance practices carried on by the Owner and promptly report to the Owner any practices which he considers unsatisfactory and not in his interests or good horticultural practices. The failure of the Contractor to inspect or report shall be construed as an acceptance by him of the Owner's maintenance practices and shall not thereafter claim that any defects which may later develop are the result of such practice.

#### **02935: Plant Maintenance**

Shade trees adjacent to parking lots shall have all limbs removed to a point 7'-0" above grade.

#### **02945: Planting Accessories**

##### Landscape Edging

Building A Mowing Edge shall be installed at all trees and around perimeter of the

##### Planters

Install drainage in outdoor plant boxes.

**End of Section**

## **Division 3: Concrete**

### **03300: Cast-In-Place Concrete**

1. The latest edition of American Concrete Institute (ACI) standards shall be followed.
2. Testing: The Contractor shall be required to retain and pay for the services of an University approved laboratory to perform all concrete testing and inspections in accordance with applicable ASTM standards. For floors, use ASTM E1155 “Standard Test Methods for Determining Floor Flatness and Levelness Using the F Number System.
3. Air-entrained concrete shall be used where concrete is exposed to the weather. With the exception of air-entrained agents, no antifreeze or other admixtures are permitted.
4. Newly placed concrete for walks, plazas, pads, and other surfaces exposed to the public shall be placed by Contractor to insure that concrete shall be free of graffiti. Freshly placed concrete with graffiti shall be removed and replaced or repaired by the Contractor at no additional cost to the University.
5. All concrete floors, which will be exposed within the finished building which are not scheduled to receive an applied finish, shall be sealed.
6. All concrete additives, where required must contain not more than 0.1% chloride ions and shall be certified as such by the Contractor.
7. If Concrete is to be used for exterior walls, a mock-up panel shall be constructed. See Division 4 - Masonry for details on panel.
8. Interior and/or exterior structural concrete surfaces should not be scheduled to receive a sandblasted finish unless specifically approved by the university.
9. Building interior structural concrete painted surfaces should not be scheduled to receive a rubbed finish. If a smooth plaster-like finish is desired, specify a thin coat of veneer plaster over the concrete substrate.
10. Building exterior exposed concrete structural frame should be detailed (incorporating insulation and finish systems) to prevent thermal loss or gain.
11. Exposed interior concrete floors should be sealed. A hardener should be required where the floor surface is subject to heavy, impact, and/or rolling loads.
12. A sample panel of exterior exposed “Architectural” concrete should be provided to establish an acceptable standard of workmanship/quality concerning finishing, texture of formed material, etc. The concrete used in the sample panel should be furnished by the project concrete supplier, and should represent the approved mix for strength and texture.



13. Exterior concrete flatwork should be six inches nominal thickness, 3000 PSI air-entrained concrete, reinforced with welded wire fabric located two inches below the top surface. The flatwork should be placed over a six inch aggregate stone base, and where intermittent vehicular traffic is anticipated, be a minimum of nine feet wide. The top surface should be broom finished with sawn or tooled joints at a maximum of six feet on-center.

**03310: High Temperature Hot Water Tunnel** see Part V – Standard Details, [HTHW Tunnel Detail, Fairfax Campus](#) , [HTHW Tunnel Top Details](#) , [HTHW Manhole Detail](#)

- a. Manholes, tunnel and piping to be designed by a Virginia registered Professional Engineer.
- b. Construct manholes, tunnel and tops for H-20 loading.
- c. Design tunnel and piping with as little abrupt elevational and lateral direction change as possible to avoid additional anchorage and expansion joints. Tunnel height can vary with site contour but height shall not exceed 8'. Tops at grade unless precluded by abrupt grade changes, road crossing or other obstruction.
- d. Lifting lugs for tunnel top removal shall be located on the sides of the tunnel top, see Tunnel Top Detail.
- e. Lifting lugs for tunnel top removal shall be epoxy coated re-bar loop, 4 per tunnel top. If tunnel tops are adjacent to a hard surface, sidewalk, or roadway, coordinate with GMU.
- f. Tunnel tops not to exceed 4,500 pounds each.
- g. For Expansion Joints, Ball Joints and Anchorage provide hatch access with cover. Hatch to be 4' x 3' min. clearance.
- h. Provide foundation drainage. Cover with #57 stone and filter fabric. Stone to extend to bottom of tunnel slab.
- i. Provide floor drains in tunnel if necessary.
- j. Provide drain channel inside tunnel. Grade drain channel to manhole.

**03400: Precast Concrete**

All pre-cast concrete that will remain exposed at contract completion shall be protected from rust stains and damage during construction.

### **03480: Bollards**

Bollards to prevent unwanted vehicular traffic on emergency access roads, plazas, etc. shall be Pro Stop collapsible type or equal. Bollards to prevent pedestrian traffic shall be Pro Stop immovable type or equal. Type and style of all bollards must be approved by GMU. See detail in Part V – Standard Details, [Collapsible Bollards, All Campuses](#)

**End of Section**

## ***Division 4: Masonry***

### **04050: Basic Masonry Materials and Methods**

Cast Stone, brick, and concrete copings are prohibited. Metal coping shall be used.

### **04060: Masonry Mortar**

1. All mortar additives, where required must contain not more than 0.1% chloride ions and shall be certified as such by the Contractor.
2. All colored mortar must be pre-approved by the University along with the brick colors as noted below.

### **04090: Masonry Accessories**

1. Thru-wall flashing in exterior cavity walls shall be 20 mil plastic equal to “Nervastral”, or approved equal.
2. In exterior masonry cavity walls, plastic weep holes shall be provided spaced not more than 2'-0" o.c. at all interruptions in the cavity caused by thru-wall flashing. Aluminum weep hole vents shall be avoided.
3. Lead coated flashings are prohibited.

## **04200: Masonry Units**

### **04220: Concrete Masonry Units**

1. Wherever possible, lightweight concrete block shall be used in masonry walls.
2. Four-inch thick CMU walls shall be avoided.

## **04700: Simulated Masonry**

### **04720: Cast Stone**

1. Manufacturer shall have a minimum of 10 years experience in the manufacture of cast stone work.
2. Samples of materials are required for approval before proceeding with any work, showing shape and colors as required. Submit samples of all anchors and relieving angles for A/E approval.
3. Testing-Laboratory: Require that the Contractor submit name and credentials of proposed testing laboratory for approval.
4. Inspection: The A/E should inspect all material, equipment, fabrication, curing and storing of cast stone work at the cast stone plant. Units shall be marked for identification and the day of casting of each unit recorded.
5. Tests: The A/E may select or cause to be selected at random from the job, representative pieces of cast stone for testing. Tests shall be made at the Manufacturer's expense and pieces of cast stone taken for testing shall be replaced by the Manufacturer without charge. A minimum of one unit per 50 units may be selected from the stone delivered to the job to be sent to an approved testing laboratory. Samples shall be tested to destruction in accordance with ASTM C 116 and test reports shall be submitted to the A/E and University.

## **04800: Masonry Assemblies**

Coursing for both brick and CMU shall be coordinated with windows and door heads so that fractions of courses are minimized.

### **Sample Panels**

Sample panels: Prior to installation of masonry work, the Contractor shall be required to erect up to 3 sample wall panels representative of completed masonry work required for project with respect to qualities of appearance, materials and construction. Locate mockups on site in locations as directed by A/E. Retain mockups during construction as standard for judging completed masonry work. As a minimum, the sample panel shall be "L" shaped 4'-0" high by 4'-0" wide with 2'-0" leg. Brick shall be on outside corner of panel. Panels shall show the proposed color range, texture, bond, mortar joints, and workmanship of all facing materials and shall include a sample of the proposed fenestration. If contrasting elements such as doors

and frames are proposed, a sample of these materials shall be included in each mock-up panel. Obtain A/E and University approval prior to start of exposed finished masonry work. Approved panels shall become the standard of comparison for all materials included and the panels shall remain undisturbed at the jobsite until the project is accepted by the University. The contractor shall then demolish mockups and remove from site after completion..

### **04900 Masonry Restoration and Cleaning**

1. Cleaning of masonry, be it brick or stone, shall be done using brushes (not those with metal bristles) and water. Diluted detergents may be used. Repeated washings are preferred to fewer washings that are too abrasive or chemically laden.
2. Sandblasting of masonry is prohibited.
3. For all structures, mortar joint profiles and mortar colors are critical and must be specifically approved by the University.
4. Waterproof covering of masonry work is required during nonworking hours and for freshly laid masonry during periods of inclement weather.
5. Experience Clause: A 5-year experience record of the subcontractor performing the restoration work is required.

### **End of Section**

## ***Division 5: Metals***

### **05100: Structural Metal Framing**

1. For erection of structural steel, the Contractor is required to provide an affidavit, at the completion of the job, to the effect that the structural steel frame is plumb and level within the normal tolerances specified by code, or the more stringent tolerances specified in the Specifications, if applicable.
2. The Contractor shall provide a certified survey showing the exact location of the centers of the columns at their top most level, exactly as installed. This information shall be incorporated into the “as built” drawings.
3. If metal is to be used for exterior walls, a mock-up panel shall be constructed. See Division 4 Masonry for details on panel.

## **05300: Metal Deck**

Galvanized metal decks conforming to ASTM A 525, G 60 are the only material to be used for metal decks, floor slabs and roof decks. Prime painted decks are not acceptable. Where applicable, the proper adhesion of sprayed on fireproofing to the decking used must be confirmed when developing specifications.

## **05400: Cold-Formed Metal Framing**

### **05450: Metal Support**

See 15060 for mechanical hangars and supports.

## **05500: Metal Fabrications**

1. Ventilation shafts penetrating the roof shall be equipped with welded anti-personnel screening to prevent unauthorized access to the building.
2. All exterior miscellaneous steel shall be galvanized and prime painted, ready for field finishing.

### **05510: Metal Stairs and Ladders**

Roofs shall be accessible by stairs and not by vertical ladders.

### **05520: Handrails and Railings**

Powder coated or stainless steel handrails should be used outside of buildings. Interior handrails should be painted steel. Protection from dissimilar metals and lime mortar (type N).

**End of Section**

## **Division 6: Wood and Plastics**

### **06050: Basic Wood and Plastic Materials and Methods**

1. For both woods and plastics, special attention is called to matters such as flame spread, fuel contribution, smoke generation and toxicity.
2. For exterior wood or plastic framed structures, see Division 4 for dimensions of Sample Panel.

### **06060: Wood Materials**

All lumber shall be properly seasoned or kiln-dried.

### **06070: Wood Treatment**

Where fireproofed wood is used, the fireproofing treatment shall be accomplished by means of pressurization. The same is true for preservation treatment for wood, such treatments being required for all wood in damp areas or in contact with earth, concrete, masonry, plaster or roofing.

### **06100: Rough Carpentry**

All lumber must be inspected, marked according to grade and certified by the appropriate bureau governing that product.

### **06130: Heavy Timber Construction**

#### Timber Trusses

Require that the Contractor provide a complete design analysis of structural components along with shop drawings. Data shall bear the seal and signature of a Virginia registered professional Architect or Engineer, attesting that design of trusses meets requirements of the specifications and complies with requirements of all codes and ordinances applicable to the particular project.

### **06200: Finish Carpentry**

Materials and Fabrication: Conform to Architectural Woodwork Institute specifications for economy or custom quality work as a minimum.

### **06400: Architectural Woodwork**

1. Plastic laminates: When specified by the designer, due consideration must be given to the particular condition of usage that will be encountered. Of special concern are flame spread, chemical resistance, fuel contribution, smoke generation and toxicity for plastic laminates and for the adhesives used to install them.

2. Prior to delivery of materials on site for installation, the Contractor shall provide the proper environmental controls for material storage (i.e. weatherproofing, climate control, etc.). These controls shall be maintained for the duration of the project.

#### **06410: Custom Cabinets**

1. Cabinet Work: Materials and fabrication shall conform to Architectural Woodwork Institute specifications for custom quality work.
2. Cabinet hardware shall be furnished and installed by the installer of cabinetry.

**End of Section**

### ***Division 7: Thermal and Moisture Protection***

#### **07050: Basic Thermal and Moisture Protection Materials and Methods**

Match color of roofing nails/screws/spikes to underside of exposed interior metal decking.

#### **07100: Dampproofing and Waterproofing**

1. Waterproofing of below grade spaces is required.
2. Material shall be protected against damage during backfill by minimum 1" thickness of extruded polystyrene insulation.
3. Dampproofing shall be applied to the exterior of all below grade walls.

### **07170: Bentonite Waterproofing**

If bentonite is used, the preferred manufacturers are American Colloid Company and Paramount Technical Products. The A/E should be aware that installation procedures are different for these two manufacturers. When required, bentonite shall be applied below the floor slab, extended down and below the footings and up the walls to within 6" of finished grade or slab-on-grade.

### **07190: Water Repellents**

Generally, water repellents shall not be used on exterior brick or masonry walls. Where required on existing buildings, silane based water repellents such as the following shall be used:

1. Chem-Trete BSM 40 as manufactured by Huls Inc., Edison, New Jersey.
2. SIL-ACT ATS-42 as manufactured by Advanced Chemical Technologies Co., Oklahoma City, OK.
3. Stifel as manufactured by Nox-Crete Chemicals, Inc., Omaha, Nebraska.
4. Klereseal 940-S as manufactured by Pecora Corporation, Harleysville, PA.

### **07200: Thermal Protection**

#### **07210: Building Insulation**

Fiberglass batt insulation shall be installed to minimize exposed fiberglass in areas needing to be accessed for inspections, maintenance, etc. Designs should encapsulate fiberglass using foil or pre-applied backing, plastic or gypsum board covering.

#### **07240: Exterior Insulation and Finish Systems (EIFS)**

1. It is preferred that such systems be avoided. When required, only the "hardcoat" systems defined as Class PM, Type A, polymer modified protective finish coating, externally reinforced as developed by the Exterior Insulation Manufacturers Association (EIMA) may be used. Such systems require mechanical fastening of extruded polystyrene insulation and reinforcing mesh, and rigid acrylic modified cement plaster finish.
2. The A/E shall pay special attention to locations of crack control joints and details of flashing and sealing at penetrations to insure a properly designed and watertight installation.



## **07300: Shingles, Roof Tiles, and Roof Coverings**

1. See the Construction and Professional Services Manual (CPSM) section 707.B.
2. The Department of Engineering & Buildings (DEB) shall approve roofing system design.
3. Consider “Cool Roof” technologies from manufacturers such as Duro-Last, Advanced Coating Systems and Dow Corning for possible energy cost savings.
4. Contractors shall recycle non-asbestos containing roofing materials that are removed as part of the contract.
5. Roofs over occupied spaces that have public access (i.e. plazas with concrete pavers over roofing / waterproofing system) shall be avoided.
6. Slope roof designs shall incorporate ice and water shield membrane at perimeter eaves and valleys.

### **07310: Shingles**

1. Roof shingles underlayment shall be at least 30 lb. felt.
2. Slate shingles, where appropriate, shall be a minimum of ¼ inch thick, weighing not less than 900 pounds per square.

## **07400: Roofing and Siding Panels**

Roof parapets are preferred on buildings greater than one-story in height for safety purposes.

### **07500: Membrane Roofing**

1. See the Construction and Professional Services Manual (CPSM) section 707.B for approved types.
2. Ballasted and/or loose laid membrane roofs must be approved in advance by the University.
3. Single-ply roofing systems (60 Mil) should be specified for low slope (less than 4 in 12 pitch) applications. Fully adhered systems are preferred. Ballasted systems must be approved in advance by the University. Mechanically fastened systems are not acceptable.
4. Ballast (if approved) should be clean, river washed gravel meeting ASTM-C-136.
5. Specify a flood test for new roof installations prior to final acceptance.

## **07600: Flashing and Sheet Metal**

### **07620: Sheet Metal Flashing and Trim**

1. Specify thin wall 16 gauge copper flashing between parapet walls and capstone.
2. Gutters and downspouts shall be (minimum) 16 gauge copper.
3. Downspouts shall tie directly to underground storm drainage system.

## **07700: Roof Specialties and Accessories**

### **07710: Manufactured Roof Specialties**

Metal coping shall be used. Cast Stone, brick, and concrete copings are prohibited.

### **07720: Roof Accessories**

1. Walkway pads shall be provided to all roof equipment and appurtenances requiring maintenance.
2. Specify service walkways (minimum 2'0" wide) appropriately located to service all roof top equipment from the roof access.
3. Provide snow guards over entrances on all roofs with a slope of 6 in 12 or greater. Do not use snow guards that require a screw connection.
4. Access to the roof from both the interior and exterior of a building shall be restricted. If interior roof hatches are used, they must be padlocked and located in areas restricted to the general public and accessible only by authorized personnel.
5. Specify roof hatches that are insulated and lockable.
6. Roofs shall be accessible by stairs and not by vertical ladders.

## **07800: Fire and Smoke Protection**

### **07810: Applied Fireproofing**

Carefully select the appropriate fireproofing material and application method to ensure compatibility with deck and column finishes.

### **07900: Joint Sealers**

1. The A/E shall pay special attention to the use and misuse of the word "caulk". Such materials are generally no longer used in modern construction and consist of oil-based materials used to glaze windows. "Caulk" is not used as a sealant in masonry joints or other exterior wall joints.

2. The use of 2-part polysulfide, 2-part polyurethane or silicone-synthetic rubber type sealant is preferable. The A/E shall determine which particular sealant type is best applicable to each individual design. Specify pourable urethane base sealants for construction joints in traffic bearing locations such as concrete walks, patios, steps and similar locations.

### **End of Section**

## ***Division 8: Doors and Windows***

### **08100: Metal Doors and Frames**

1. Exterior doors shall be not less than 16 gauge steel. The top channel of each metal door shall be solid without pockets which collect dirt and water. All exterior doors and frames shall be galvanized.
2. Interior doors shall be not less than 18 gauge steel.
3. All door frames shall be 16 gauge. Knock-down frames are prohibited unless specifically approved in writing by the University.

### **08200: Wood and Plastic Doors**

1. Doors to rooms storing high value items such as computers, scientific equipment, etc. shall have solid doors without vision panels and without adjacent sidelights.
2. The A/E must review door manufacturer list early in the design process and receive approval for the list from the University.

## 08210: Wood Doors

1. Exterior wood doors are prohibited except if replacing existing doors.
2. All interior wood doors shall be solid core, either mineral core where a fire rating is required, high density particle board core, or wood stave core.
3. Wood doors which are to receive clear or stained finish shall be factory finished and pre-machined for hardware. Specify that the door edges are fabricated of matching wood to the face.

## 08300: Specialty Doors

### 08330: Coiling Doors and Grilles

Specify only fusible links for automatically closed, rolling steel fire doors. Do not specify both detectors and fusible links.

#### Fire Shutters

Provide water curtains in lieu of fire shutters.

## 08400: Entrances and Storefronts

1. Aluminum doors shall have minimum 5" stiles, 5" stop rail and 6-1/2" bottom rail (wide stile doors).
2. All hardware, with the exception of cylinders, shall be provided and installed by the aluminum door manufacturer. Cylinders shall be provided under finish hardware section of the Specifications.
3. Hardware: The following hardware shall be provided (No substitutions except those indicated):

| ITEM         | MANUFACTURER                | MODEL NO.  |
|--------------|-----------------------------|--|
| Hinge        | Roton Continuous or Stanley | FBB-199 US32D  |
| Closer       | LCN                         | 4040 x CUSH x Alum.  |
| Panic Device | Von Duprin or Precision     | 99 x 990NL (RHRB Door)<br>1103 x 17 (RHRB Door)<br>1102 x 17 (LHRB Door) |
| Mullion      | Reed                        | 8000 Series (Steel)  |
| Threshold    | Reese, or Approved Equal    |  |

Weather-strip by door manufacturer

4. All finish hardware shall be supplied US26D, with the exception of door closers which shall be sprayed aluminum finish.
5. Overhead concealed door closers, floor closers, pivot hung doors and door manufacturer's pull trims are not acceptable.
6. Typical door schedule follows:

A. Pair Aluminum Entry Doors:

Each Leaf;

1 - Hinge Roton 780-053HD X Alum.

1 - Panic Device Von Duprin 99 X 99ONL X US26D

1 - Door Closer LCN 4040 X CUSH X Alum.

Per Pair;

1 - Removable Mullion Yale M-100

1 - Threshold Zero or Approved Equal.

B. Single Aluminum Entry Door

1 - Hinge Roton 780-053HD X Alum.

1 - Panic Device Von Duprin 99 X 99ONL X US26D

1 - Door Closer LCN 4040 X CUSH X Alum.

Threshold Zero or Approved Equal

Silencers GJ-64

**08460: Automatic Entrance Doors**

| ITEM                 | MANUFACTURER                                      | MODEL NO.                                  |
|----------------------|---|--|
| Hinge                | Roton or Select Products Limited. No Substitution |  |
| Automatic Operator   | Besam (Low Energy Type). No Substitutions         |  |
| (* ) Electric Strike | Von Duprin 6000 Series 24VDC Fail secure          | Model to suit application. No Substitution |
| (* ) Panic Device    | Von Duprin  | 99NL-F x US26D No Substitutions            |
| Threshold            | Zero (or) Approved Equal.                         |  |
| Weather Strip        | Zero (or) Approved Equal                          |  |

NOTE: (\*) May not be required depending on application.

1. Hinge and Panic Device shall be installed with thru-bolts. All exposed screw and bolt heads shall be spanner head.
2. Sufficient reinforcement shall be provided for overhead surface mounted door operators.
3. 120VAC power shall be supplied to each operator.
4. Door operator controls: A self contained solid state circuit shall control the operations and switching of the swing power operator. The electronic control shall provide low voltage power supply for all means of actuation. No external or auxiliary low voltage power source will be allowed. The control shall also include time delay 1-60 seconds, for normal cycle, as well as the following built-in features:
  - A. Torque limiting for controlled forces on opening,
  - B. Acceleration control for smooth starts and recycle,
  - C. Special circuitry for reducing power to the motor when door is in "Hold-Open" mode, extending longevity and assuring reliability.
5. Safety Sensors: VISONPULSE: The swing door presence sensor shall be mounted to each side of the swing door approach and swing path and shall be complete in all respects consisting of the following:
  - A. Extruded Aluminum housing of 6063-T52 alloy sized to run full width of door, integral high impact, tinted acrylic lenses and injection molded end caps.
  - B. Solid state electronics interfaced to alternating rows of light emitting diodes and receivers contained within the extruded aluminum housing.
  - C. Long/short range switch and flexible cable.
  - D. Sensor shall be capable of operation within temperature ranges of -20F and 160F. Vision pulse shall detect presence not motion and shall not be restricted in application due to door design, construction, material or glass type. Ambient light and radio frequencies shall not interfere with the sensors performance.

### **08500: Windows**

1. Specify standard glass not requiring special order or premium price.
2. Wherever possible, windows should be specified that have the muntins installed between the panes of glass.

## 08600: Skylights

Skylights shall be avoided. Special permission for the use of skylights must be obtained from the University and generally will not be granted without extremely strong reasons.

## 08700: Hardware

The following hardware for the types of buildings indicated shall be provided.

| ITEM                  | MANUFACTURER                  | MODEL NO.<br>ACADEMIC<br>BUILDINGS          | MODEL NO.<br>HOUSING<br>FACILITIES |
|-----------------------|-------------------------------|---|------------------------------------|
| Butts (Int.)          | Stanley                       | FBB-179 4-1/2 USP<br>or approved equal      | FBB-179 4-1/2 USP                  |
| Butts (Ext.)          | Stanley                       | FBB-199 4-1/2<br>US32D or Approved<br>Equal | FBB-199 4-1/2<br>US32D             |
| Hinges                | Roton or Zero                 | Continuous (to suit<br>application)         |                                    |
| Locksets & Latch Sets | Best                          |   |                                    |
| Key Cylinders         | Best                          | 7 pin                                       |                                    |
| Flush Bolts           | Ives                          | 457-B26D or<br>Approved Equal               | 457-B26D                           |
| Panic Devices         | Von Duprin or<br>Precision    | 99x990NL x US26D<br>1103 x 17               | 99 Series<br>1100 Series           |
| Removable Mullions    | Yale                          | M100 Series                                 | M100 Series                        |
| Door Closers          | LCN                           | 4040 x Sprayed Alum.                        | 4040 Series                        |
| Door Stops / Holders  | Glynn - Johnson               | 500 Series Non H. O.                        | 500 Series Non H. O.               |
| Wall Bumpers          | Ives                          | 407 - 1/2 x B26D or<br>Approved Equal       | 407 - 1/2 x B26D                   |
| Push Plates           | Rockwood                      | 70 3-1/2 x 15 US26D                         | 70 3-1/2 x 15<br>USD26D            |
| Pull Plates           | Rockwood                      | 123 x 73 3-1/2 x 15                         | 123 x 73 3-12 x 15                 |
| Mop Plates            | Rockwood                      | 18-8"                                       | 18-8"                              |
| Kick Plates           | Rockwood or<br>Approved Equal | 18-12"                                      | 18'12"                             |

1. Specifying hardware by allowance is prohibited. Hardware sets shall be developed for each unique condition for the building.
2. The Virginia Uniform Construction Code, Barrier Free Subcode requires that door handles be easily grasped by handicapped persons. This necessitates lever handles on virtually all doors in University buildings.
3. Mop plates and kick plates shall be 1" less than width of door on hinge side, 1-1/2" less than width of door on stop side.
4. Hardware items, not set forth herein, shall be subject to verification by application, on a per project basis.
5. Floor type or overhead Concealed door closers are NOT acceptable.
6. Concealed Vertical Rod Type Panic Devices are NOT acceptable. Panic devices by manufacturers other than specified above are NOT acceptable. Panic devices by the specified manufacturers, shall be acceptable ONLY in the SERIES specified herein.
7. Specify push-bars in lieu of vertical rods since they latch at center and require less maintenance.
8. Removable Mullions, as specified herein, shall be used on entry doors, where doors are paired.
9. As hardware applications may vary, due to special requirements, or code restrictions. These applications shall be considered on a per project basis.
10. At drywall or plaster walls, use closers with CUSH function. Wall bumpers on drywall or plaster are prohibited. Floor bumpers are prohibited.
11. Exterior doors which are not the main access point to the building shall be exit only, and shall be connected to the fire alarm system. Such doors shall be clearly marked on the inside that opening the door will sound an alarm.
12. Provide power circuit(s) for automatic door openers.
13. Typical Door Schedules are as follows:
  - A. Non-Public Toilet:
    - 1-1/2 pr. Butts
    - 1 - Stanley FBB179 X US26D
    - 1 - Privacy Set Schlage L9040 LX03 X US26D
    - 1 - Door Closer LCN 4041 X Alum.



Silencers GJ-64

B. Storage Room, Custodial Closets

Note: Same set shall apply to Mechanical and Electrical Rooms. However, lever trim shall not be used (knurled knob trim required).

1-1/2 pr. Butts Stanley FBB179 X US26D

1 Lockset Schlage L9080 LX03 X US26D

Silencers GJ-64

C. Office Doors

1-1/2 pr. Butts Stanley FBB179 X US26D

1 Lockset Schlage L9050 LX03 X US26D

1 Door Closer LCN 4041 X Alum. (optional)

Silencers GJ-64

D. Public Toilet

1-1/2 pr. Butts Stanley FBB179 X US26D

1 - Lockset Yale 313ST X US26S

1 Pull Plate Rockwood or approved equal

1 Push Plate Rockwood or approved equal

1 Kickplate Rockwood or approved equal

1 Mop Plate Rockwood or approved equal

1 Closer LCN 4041

Silencers GJ-64

E. Classrooms, Laboratories

1-1/2PR. Butts Stanley FBB179 X US26D

1 - Lockset Schlage L9070L X 03 X US26D

1 - Closer LCN 4041 (optional)

Silencers GJ-64

*Elevator and Fire Alarm Panel Keys*

Specify locking hardware for elevators and fire alarm panels such that it can be operated with existing keys.

**08710: Finish Hardware Master Specification**

**PART 1 - GENERAL**

**1.01 SUMMARY:**

A. Section Includes: Finish hardware except as otherwise specified or specifically omitted herein.

B. Related Sections:

1. Section 06200 - Finish Carpentry: Installation of finish hardware.
  2. Section 08100 - Standard Steel Doors and Frames.
  3. Section 08210 - Wood Doors.
  4. Section 08910 - Aluminum Storefront Doors & Frames
  5. Section 16000 - Access Control System
- C. Specific Omissions: Hardware for the following is specified or indicated elsewhere.
1. Windows
  2. Cabinets of all kinds, including open wall shelving and locks.
  3. Signs, except as noted.
  4. Toilet accessories of all kinds including grab bars.
  5. Installation.
  6. Rough hardware.
  7. Folding partitions, except cylinders where detailed.
  8. Sliding aluminum doors.
  9. Angle sill threshold.
  10. Corner guards.
- D. References / Industry Standards: Hardware specified in this section subject to compliance of the follows agency:
1. NFPA-80 Standard for Fire Doors and Windows.
  2. NFPA-101 Life Safety Code.
  3. ADA – The American with Disabilities Act – Title III – Public Accommodations.
  4. UL – Underwriter’s Laboratories.
  5. WHI – Warnock Hersey International.
  6. ANSI / BHMA – American National Standards Institute / Builders Hardware Manufactures Association.
  7. State and Local Codes, including the “Authority Having Jurisdiction”.
  8. DHI – Door and Hardware Institute

## **1.02 SUBSTITUTIONS & SUBMITTAL**

- A. Items listed with NO SUBSTITUTE have been requested by University to match existing products. No alternate products will be considered for review, provide products as specified.
- B. SUBMITTALS: Submit, for review, six (6) complete copies of the finish hardware schedules within three (3) weeks after the hardware supplier receives the purchase order. Organize schedule into “Hardware Sets” with an index of doors and heading, indicating complete designations of

every item required for each door or opening. Include the following information:

1. Type, style, function, size, quantity and finish of each hardware item.
  2. Name, part number and manufacturer of each item.
  3. Fastenings and other pertinent information.
  4. Location of hardware set cross referenced to indications on drawings both on floor plans and in door schedule.
  5. Explanation of all abbreviations, symbols, and codes contained in schedule.
  6. Mounting locations for hardware.
  7. Door and frame sizes and materials.
  8. Submit manufacture's technical data and installation instructions for the electronic hardware.
  9. Catalog cuts.
  10. Submit any samples necessary, as required by the Architect/Owner.
- C. Templates: Where required, furnish hardware templates to each fabricator of doors, frames and other work to be factory-prepared for the installation of hardware.

### **1.03 QUALITY ASSURANCE:**

- A. Qualifications:
1. Obtain each kind of hardware (latch and locksets, exit devices, hinges, and closers) from only one manufacturer, although several may be indicated as offering products complying with requirements.
  2. Hardware supplier to be a qualified, Factory Authorized, direct Contract Hardware Distributor of the products to be furnished. In addition, the supplier to have in their regular employment an certified Architectural Hardware Consultant (AHC) who will be made available at reasonable times to consult with the Owner, Architect, and/or Contractor regarding any matters affecting the finish hardware on this project.

3. The hardware supplier should maintain an office and warehouse within a sixty-five (65) miles radius of the job and maintain an inventory and field service staff in order to service the project properly.
  4. Pre-Installation Conference for Finish Hardware and/or Electronic Hardware: Prior to installation of the hardware, the hardware consultant shall arrange a conference between the contractor, installers and related trades to review materials, procedures and coordinating related work.
- B. Schedule Designations: Except as otherwise indicated, the use of one manufacturer's numeric designation system in schedules does not imply that another manufacturer's products will not be acceptable, unless they are not equal in design, size, weight, finish function, or other quality of significance. See 1.02 A for substitutions.
- C. Exit Doors: Openable at all times from the inside without the use of a key or any special knowledge or effort.
- D. Fire-rated openings: Provide hardware for fire-rated openings in compliance with NFPA Standard No. 80. This requirement takes precedence over other requirements for such hardware. Provide only such hardware which has been tested and listed by UL for the type and size of door required, and complies with the requirements of the door and the door frame labels. Latching hardware, door closers, ball bearing hinges, and seals are required whether or not listed in the Hardware schedule.
1. Where panic exit devices are required on fire-rated doors, provide supplementary marking on door UL label on exit device indicating "Fire Exit Hardware."

#### **1.04 DELIVERY, STORAGE, AND HANDLING:**

- A. Acceptance at the Site: Individually package each unit of finish hardware complete with proper fastening and appurtenances, clearly marked on the outside to indicate contents and specific locations in the Work.
- B. Deliver packaged hardware items at the times and to the locations (shop or field) for installation, as directed by the Contractor.

#### **1.05 PROJECT CONDITIONS:**

- A. Coordination: Coordinate hardware with other work. Furnish hardware items of proper design for use on doors and frames of the thickness, profile, swing security and similar requirements indicated, as necessary for the proper installation and function, regardless of omissions or conflicts in the information on the Contract Documents.

- B. Upon request, check the Shop Drawings for doors and entrances to confirm that adequate provisions will be made for the proper installation of hardware.

**1.06 WARRANTY:**

- A. Provide written guarantee from hardware manufacture, as well as hardware supplier, as follows:
  1. Locksets: Five (5) years
  2. Exit Devices: Five (5) years
  3. Closers: Ten (10) years
  4. Electronic closers: Two (2) years.
  5. All other Hardware: Two (2) years.

Warranty shall commence with substantial completion of the project.

**PART 2 - PRODUCTS**

**2.01 MANUFACTURERS:**

- A. Approval of manufacturers other than those listed shall be in accordance with paragraph 1.02 A, except for items marked No Substitute.

| <u>Item:</u>            | <u>Manufacturer:</u> | <u>Approved:</u> | <u>Approved</u> |
|-------------------------|----------------------|------------------|-----------------|
| Hinges                  | Hager                | Stanley          | Mckinney        |
| Locks                   | Best                 | No Substitute    |                 |
| Cylinders/Cores/Keys    | Best                 | No Substitute    |                 |
| Closers                 | Ryobi                | LCN              | Sargent         |
| Exit Devices            | Precision            | Von Duprin       | Sargent         |
| Keyed Removable Mullion | Precision            |                  | Von Duprin      |
| Sargent                 |                      |                  |                 |
| Pulls                   | Rockwood             | Hager            | Ives            |
| Silencers               | Rockwood             | Hager            | Ives            |
| Kickplates              | Rockwood             | Hager            | Ives            |
| Stops                   | Rockwood             | Hager            | Ives            |
| Key Cabinet             | Lund                 | Telkee           |                 |
| Thresholds              | National Guard       | Zero             | Pemko           |
| Seals/Sweeps            | National Guard       | Zero             | Pemko           |

- B. Furnish all items of hardware required to complete the work in accordance with specifications and plans.
- C. Carefully inspect Project for the extent of the finish hardware required to complete the Work. Where there is a conflict between these Specification and the existing hardware furnish finish hardware to specification.

## 2.02 MATERIALS:

- A. Locksets and Latches, shall be Best 9K extra-heavy-duty cylindrical with Best 7-pin interchangeable core to match existing product throughout the Campus. Lockset and Cores to be of the same manufacturer to maintain complete lockset warranty. Locks to have solid shank with no opening for access to keyed lever keeper. Lock chassis must be through-bolted outside of the lock chassis prep to prevent rotation of chassis after installation. Lock manufacturer shall provide a five (5) year warranty, in writing, to the Owner, along with three copies of the lock service manual. Strikes shall be 16 gauge curved brass, bronze or stainless steel with a 1" deep box construction, and have sufficient length to clear trim and protect clothing.
1. Lock Series, Design and Finish: Best 93K7 15D x 626
  2. Cores / Cylinders: Best 7-Pin with "Premium" Keyway to match existing system.
- B. Hinges: Outswinging exterior doors shall have non-removable pin hinges (NRP). Exterior hinges to be brass, bronze or stainless steel material. Hinges shall be extra heavy weight for high frequency openings or doors over 36" in width. All hinge open widths shall be 4.5" minimum, but of sufficient size to permit door to swing 180. Furnish hinges with three knuckles and concealed bearing. Plain bearing shall not be permitted.
1. Furnish 3 hinges per leaf to 7 foot 6 inch height. Add one for each additional 30 inches in height or fraction thereof.
  2. Provide hinges as listed in schedule.
- C. Exit Devices: Furnish all sets at wood doors with sex bolts unless otherwise specified in Wood Door Section/ Hardware blocking. Trim of exit devices to match trim of locksets. Provide rim devices at single doors. At pairs of doors with low visibility provide two rim devices with key removable mullion. At doors with high visibility, provide concealed vertical rod devices. Depending on location, at exterior openings provide two surface vertical rod devices or two rim devices with key removable mullions.
1. Exit Device Series: Precision "APEX" Series with cylinder dogging (CD) at standard non rated hollow metal and wood doors openings. Omit CD at fire rated doors.
  2. Exit Device Series: Precision "NSA" Series with cylinder dogging (CD) at narrow stile aluminum door openings. Omit CD at fire rated doors.
  3. Keyed Removable Mullions: Precision KR822 or FL-KR822 with Stabilizers 100-96. Mullion shall be furnished with a cylinder keyed into the existing GMU keying system.

4. Heavy Duty Lever Trim: Precision V39L Vandal Resistant Lever Trim.
- D. . Surface Door Closers: Full rack and pinion type with removable non-ferrous cover. Provide sex bolts at all wood doors unless otherwise specified in Wood Door Section/Hardware blocking. Place closers inside building, stairs, and rooms. Closers shall be non-handed, non-sized and adjustable.
1. Closer Series: Ryobi D-4550 / D-4551 Forged Heavy Duty Arm (HDA)
  2. Provide multi-size 1 through 6 at all doors rated or not.
  3. Exterior and high frequency openings to receive D-4550 Series with HDA.
  4. Interior and low frequency openings to receive D-3551 Series with HDA.
  5. All closers shall be R14 die cast aluminum alloy material.
  6. Flush transom offset brackets shall be used where parallel arm closers are listed for doors with fixed panels over.
  7. Drop brackets are required at narrow head rails.
  8. Set exterior doors closers to have 8.5 lbs maximum pressure to open, interior non-rated at 5 lbs , rated openings at 12 lbs. and meet all ADA requirements.
  9. All closers shall come standard with barrier free feature and all weather fluid.
- E. Kickplates: Provide with four beveled edges, 10 inches high by width less 2 inches on single doors and 1 inch on pairs of doors unless otherwise specified.. Furnish Type "A" screws to match finish.
- G. Seals: All seals shall be finished to match adjacent frame color. Seals shall be furnished as listed in schedule. Material shall be UL listed for labeled openings.
- H. Screws: All exposed screws shall be Phillips head.
- I. Silencers: Furnish silencers on all interior frames, 3 for single doors, 2 for pairs. Omit where any type of seals occur.

### **2.03 FINISH:**

- A. Generally to be BHMA 626, Satin Chrome Finish.
  1. Protection Plates, Push, Pulls shall be BHMA 630, Stainless Steel Finish.
- B. Unless otherwise noted, spray door closers to match other hardware.
- C. Aluminum items shall be finished to match predominant adjacent material. Seals to coordinate with frame color.

## **2.04 KEYING REQUIREMENTS:**

- A. All keyed locksets and cylinders shall be provided with Best brass construction cores and keys during the construction period. Plastic construction cores will not be permitted. Construction control and operating keys and core shall not be part of the University permanent Best keying system or furnished on the same keyway (or key section) as the University permanent Best keying system. Permanent Best cores and keys shall be prepared according to the approved keying schedule and will be furnished to GMU by the local Best factory representative, prior to occupancy.
- B. All cylinders shall be Best 7-pin, interchangeable core "Premium" Keyway to match existing key system. (Note, "WC" keyway at Fairfax and Arlington Campus and "WH" keyway at Prince William Campus.)
- C. Permanent Best keys and cores shall be stamped with the applicable key mark for identification. These visual key control marks or codes will not include the actual key cuts. All permanent keys and key blanks shall be stamped "GMU - Unlawful to Duplicate."
- D. Furnish keys in the following quantities:
  - 1. Zero (0) each Grand Masterkeys
  - 2. Zero (0) each Masterkeys per set
  - 3. Four (4) each Change Keys each keyed core
  - 4. Zero (0) each Permanent Control key
  - 5. Nine (9) each Construction Keys
  - 6. One (1) each Construction Control key
  - 7. Two hundred (200) key blanks

Special Note: All Grand Masterkeys, Masterkeys, and other security keys shall be "cut" by George Mason University Security Department. Furnish one hundred (100) extra key blanks in the appropriate GMK & MK keyway for Owners use.

- E. The Owner, or the Owner's agent, will install permanent cores and return the construction cores to the Hardware Distributor. All Construction cores and keys remain the property of the Hardware Distributor.
- F. Keying schedule: Submit three copies of separate detailed schedule indicating clearly how the Owner's final instructions on keying of locks has been fulfilled.

## **2.05 KEY CABINET:**

- A. Furnish one (1) Key Cabinet similar to Lund 1205A , with capacity of one (1) hook per cylinder, plus an additional one hundred (100) percent expansion. Cabinet shall be prepared to accommodate a mortise cylinder.



Provide one (1) Best cylinder keyed into the existing GMU Grandmaster key system.

## **PART 3 - EXECUTION**

### **3.01 HARDWARE LOCATIONS:**

- A. Hinges:
  - 1. Bottom Hinge: 10 inches from door bottom to bottom of hinge.
  - 2. Top Hinge: 5 inches from door top to top of hinge.
  - 3. Center Hinge: Center between top and bottom hinge.
  - 4. Extra Hinge: 6 inches from bottom of top hinge to top of extra hinge.
- B. Lock: 38 inches from finished floor to center of lever or knob.
- C. Push Bar: 44 inches from bottom of door to center of bar.
- D. Push Plate: 44 inches from bottom of door to center of plate.
- E. Pull Plate: 42 inches from bottom of door to center of pull.
- F. Exit Device: 39-13/16 inches from finished floor to center of pad.
- G. Deadlock Strike: 44 inches from floor, centered.

### **3.02 INSTALLATION:**

- A. Hardware is to be installed by experienced finish hardware installers only.
- C. Install finish hardware in accordance with the approved hardware schedule, the manufacturers' printed instructions and in accordance with Recommended Locations for Architectural Hardware for Standard Steel Doors and Frames, by the Door and Hardware Institute. Prefit hardware before finish is applied; remove and reinstall after finish is complete and dry. Install and adjust hardware so that parts operate smoothly, close tightly, and do not rattle.
- C. Installation shall conform to local governing agency security ordinance.

### **3.03 ADJUSTING:**

- A. Adjust and check each operating item of hardware and each door to ensure proper operation or function of every unit. Replace units which cannot be adjusted to operate freely and smoothly.
- B. Inspection: Hardware supplier shall inspect all hardware furnished within 10 days of contractor's request and include with his guarantee a statement

that this has been accomplished. Inspector or Contractor shall sign off the hardware as being complete and correctly installed and adjusted. Further corrections of defective material shall be the responsibility of his representative.

### **3.04 SCHEDULE OF FINISH HARDWARE:**

- A. Legend of listed manufacturers:
  - HA Hager
  - BE Best
  - PR Precision
  - RY Ryobi
  - NG National Guard
  - RO Rockwood
  
- B. The items listed in the following "Schedule of Finish Hardware" shall conform throughout to the requirements of the foregoing specification. The last column of letters in the Hardware Schedule refers to the manufacturer abbreviation listed above.
  
- C. The Door Schedule on the Drawings indicates which Hardware Set is used with door.

### **3.05 ACCESS CONTROL SYSTEM:**

- A. Coordinate the preparation of doors and frames with the University access control system shall be the responsible of the door/frame/ hardware distributor. Doors and frames scheduled to receive access control devices shall be preparation at the factory to accept the hardware listed in the hardware sets, and, in other noted spec section.

### **3.06 HARDWARE SETS:**

Special Note: Architect / Hardware Consultant, please insert hardware sets as necessary for project, below:

Hardware Set 01

Each opening shall have:

## **08740: Electro-Mechanical Hardware**

### *Card Key Locking Hardware*

1. Card Access Control (CAC) systems shall be specified for all building entrances at a minimum, and meet the following criteria:
  - A. The University uses Best Access Systems. CAC system shall be low voltage, flexible and expandable. It shall employ state of the art digital and coding technologies, be designed and manufactured for high speed processing and maximum reliability. It shall be of modular design capable of interfacing with IBM or compatible type PC's.
  - B. Software programs employed in the system(s) shall be capable of controlling from one (1) to eight hundred (800) access points per site. All access attempts are to be recorded, printed and/or displayed at the operator's option.
  - C. The CAC system shall be designed to operate in automatic and command programming modes, respond to alarm generated reports and modify the data base configuration with all activities available to be stored, printed or displayed at the operator's option.
2. Operator interface with the system shall be through a video display monitor and/or automatic printer and/or IBM or compatible type PC's. Monitor displays and printed information shall use clear, complete English language descriptions and shall not require the operator to interpret numeric or coded data.
3. If a card key access control system is required for the building interior, specific specifications may be obtained from the Project Manager.
4. The card key system shall be coordinated with the University Security Systems Manager.
5. Insure metal studs do not interfere with magnetic card readers.

**End of Section**

## **Division 9: Finishes**

### **09050: Basic Finish Materials and Methods**

1. Extravagant, costly and/or high maintenance finishes should be avoided.
2. The University must approve the color selections of all finishes.
3. Finishes that have minimal tolerances and place unrealistic expectations on the installing contractor(s) should be avoided.
4. The following is a general guideline for finishes in various locations. This is offered a suggestion only and is subject to the A/E's judgment and the specific building requirements.
  - a. Offices: Carpet.
  - b. Seminar and conference rooms: Carpet.
  - c. Library and reading rooms: Carpet.
  - d. Restrooms: Ceramic tile, dark colored grout. Dark grout and ceramic tile covered base should extend up walls at least 4”.
  - e. Classrooms: Vinyl composition (VCT).
  - f. Corridors: Terrazzo or VCT. Carpet may be used on upper floors in buildings where spills are not anticipated.
  - g. Lounges: VCT unless no vending area nearby, in which case carpeting may be considered.
  - h. Stairs: Terrazzo or rubber tile.
  - i. Laboratories: Seamless Epoxy or Sheet Vinyl (vinyl tile is prohibited).
  - j. Entrances and Vestibules: Pedigrid/pedimat for recessed and on-surface areas (recessed preferred).
  - k. Lobbies: Terrazzo, Ceramic Tile or VCT.
  - l. Multi-Purpose Rooms: Wood flooring.
  - m. Janitor's Closets: Ceramic tile with 4” base and dark colored grout,
5. Special attention shall be given to flame spread ratings of all finishes. All materials shall be specified with flame spread requirements. Require the Contractor to indicate the actual ratings on all submissions.
6. Floor treatment for exit stairways, corridors, common areas, assembly rooms, resident hall rooms and apartments shall be constructed of not less than Class I materials as tested to ASTM E648. Testing must be performed by an approved agency and each lot of carpeting procured shall be accompanied with a certified test report identifying the carpet by manufacturer and style name, and shall be representative of the current construction of the carpet. The carpet must also pass the DOC FF-1 “pill test” (CPSC 16 CFR, part 1630).
7. Floor treatment for offices and other areas not specified above shall be classified not less than Class II in accordance with ASTM E648. Testing must be performed by an approved agency and each lot of carpeting procured shall be accompanied with a certified test report identifying the carpet by manufacturer and style name, and shall be

representative of the current construction of the carpet. The carpet must also pass the DOC FF-1 "pill test" (CPSC 16 CFR, Part 1630).

8. Where floor coverings meet building expansion joints, details will be provided to ensure smooth transitions occur that will not present trip hazards or maintenance problems. Floor coverings shall not cover expansion joints without a transition. Pay special attention to providing a smooth functional and attractive transition detail.
9. For ceilings, use tile in lieu of gypsum board when possible for better maintenance access.

## **09300: Tile**

### **09310: Ceramic Tile**

1. Floor Tile: 2' x 2' porcelain ceramic tile equal to Dal-Keystone Porcelain Ceramic Mosaics by Dal-Tile Corporation. Standard Grade quality conforming to ANSI 137.1-1980.
2. Wall Tile: 4-1/2" x 4-1/2" glazed ceramic tile equal to Dal-Tile Glazed Interior Wall Tile by Dal-Tile Corporation. Standard Grade quality conforming to ANSI 137.1-1980.
3. Ceiling Tile: Ceramic panels, 2' x 2' x 5/8" high density, resistant to moisture, steam and chemicals, equal to Ceramaguard 601A by Armstrong.

### **09330: Quarry Tile**

Quarry Tile Care: In instances where quarry tile is specified as the building floor covering, the Contractor will clean the quarry tile floor with Hillyard Seal - 341 or approved equal. Colors selected shall minimize the showing of dust and/or footprints.

## **09500: Ceilings**

### **09510: Acoustical Ceilings**

1. Do not use "accessible concealed spline" ceilings. Such materials may only be used where acoustical materials are directly adhered to the underside of concrete slabs and as approved by the Project Manager.
2. For suspended ceiling systems, ceiling grids, runners and tees shall not be less than 15/16" wide in profile.
3. Specify standard ceiling tiles not requiring special order or premium price.
4. Acoustical Tile: 2' x 2' 5/8", non-directional, mineral board lay-in panels, equal to Armstrong #770 or Clotex #157 Safetone, fissure tone.

5. Suspended Grid: Intermediate duty, double web, exposed grid system, equal to DX system by Donn Corporation; main tee equal to DX-24, cross tee equal to DX-422.

### **09600: Flooring**

1. Provide section details of expansion/control joints and for all locations where different types of finish floor materials meet.
2. Specify the type of floor sealer and wax to be used by the contractor at building turnover.

### **09650: Resilient Flooring**

1. Avoid use of fissured, or ribbed or otherwise textured vinyl composition or rubber tile, unless slip resistance is important. Such tiles are very difficult to clean.
2. Select color and finish to make imperfections less noticeable. High gloss application tends to show too much of the floor imperfections.
3. Floor Tile: Vinyl composition, 1/8" x 12" x 12", as manufactured by Kentile, Armstrong or equal, meeting or exceeding Federal Specification #SF-T-321 B, Type 4.
4. Colors selected shall minimize the showing of dust and/or footprints.
4. Base: Rubber cove base, 4" or 6", as manufactured by Roppee Rubber, Johnsonite Rubber Company, Flexco, or equal, meeting or exceeding Federal Specification #SF-W-40A, Type 1.

### **09680: Carpet**

1. Notarized Statement from Manufacturer: All carpeting and assembly (including padding) shall be certified to have a minimum flame spread and smoke developed rating of 75 or less, by either a copy of the ASTM E-84 Tunnel Test from an approved testing laboratory or a notarized statement from the manufacturer that their product has passed this test, in an approved independent testing laboratory. A list of all toxic-gases noted during the combustion test, including the relative quantities developed, shall be included with the notarized statement. Chemical analysis of the gases shall show degree of toxicity, irritability and such other characteristics which might be dangerous to the health of building occupants during a fire. Excesses of toxic gases may be cause for rejecting proposed materials.
2. Color: see PART II – FACILITIES AND SPACES, Master Plan, Color.

## **09900: Paints and Coatings**

1. Specify eggshell paint in lieu of flat paint.
2. See 15075 for mechanical identification

**End of Section**

## ***Division 10: Specialties***

### **10100: Visual Display Boards**

#### **10110: Chalkboards**

Vitrasite, standard black with trim, chalk rails and track for map hooks. Sliding boards to allow for greater flexibility. Chalkboards should be specified only when specifically requested by the University.

#### **10115: Markerboards**

Dry marker boards are preferred.

#### **10120: Tackboard and Visual Aid Boards**

Tack Boards – Above or adjacent to chalk boards

## **10150: Compartments and Cubicles**

### **Toilet Partitions**

Toilet partitions shall be ceiling hung or wall hung. In either case, adequate structure shall be employed to prevent sagging and warping.

## **10350: Flagpoles**

Coordinate flagpole placement with the University.

## **10400: Identification Devices**

### **10430: Exterior Signage**

Site planning concepts should include suggested exterior signage locations. Typically, no signage is attached directly to the exterior of a building, in conformance to the Campus Master Plan. A construction sign cannot be a requirement of the contract documents. Should the contractor choose to have a construction sign, the sign must conform to the requirements set forth by the university.

### **10440: Interior Signage**

Interior signage for all Capital Improvements Projects will be listed on a schedule provided by the A/E to the University. Signs required by building codes shall be included in the contract by the A/E.

## **10500: Lockers**

### **10520: Fire Protection Specialties**

#### *Fire Extinguishers, Cabinets, and Accessories*

1. Fire extinguishers are provided by the University.
2. Break-glass faced fire extinguisher cabinets are prohibited. Use solid cabinet, unlocked, with small window made of polycarbonate or other plastic glazing to verify the presence of fire extinguisher.
3. Bottom of cabinet shall be mounted 16" above floor.
4. Fire extinguisher cabinets shall be incorporated into all projects as required by code and sized for the required extinguisher.
5. Contract specifications shall identify the extinguisher type and size and note that the extinguishers shall be provided and installed by the University.



## **10800: Toilet, Bath, and Laundry Accessories**

### **10810: Toilet Accessories**

1. Toilet Tissue Dispensers: Provided by the University.
2. Roll-Towel Dispensers: Provided by the University.
3. Soap Dispensers: Provided by the University.
4. Sanitary Dispensing Vendors: Rochester Midland Model J2 White Enamel Metal 14 3/4" w 6 1/2" d x 20"d x 20"h, or approved equal.
5. Electric Hand Dryers: N/A.

**End of Section**

## ***Division 11: Equipment***

### **11400: Food Service Equipment**

The A/E shall use the services of a food service equipment specialist in preparation of kitchen areas and other food preparation areas when required in the building. Such areas shall be designed in close coordination with the University food service personnel.

### **11600: Laboratory Equipment**

#### **Fume Hoods**

##### **1. General**

All new hoods shall meet testing criteria established by the American Society of Heating, Refrigerating, and Air Conditioning Engineers, Inc. (ASHRAE) in ANSI/ASHRAE 110-1995, "Method of Testing Performance of Laboratory Fume Hoods". All hoods, bench, distillation, or walk-in types, shall have proper aerodynamic design to minimize eddy currents and assure against air movement from the hood into the laboratory. This is accomplished by airfoil sides and an aerodynamically designed sill with a one-inch air gap between it and the hood floor. An "air by-pass" shall be present on all hoods to control the range of the face velocity as the hood sash is raised and lowered. The face velocity at any sash position should never exceed three times the "open face" velocity. It is necessary to keep the air velocities within this range to reduce eddy currents around the edges of the hood face.

##### **2. Location**

- A. All new fume hoods shall be an integral part of the laboratory design and all laboratory renovations shall also rectify improper hood locations.
- B. Fume hoods shall be located in a room so that air currents generated in the room will not interfere with the hood's ability to capture and eliminate vapors, mists, and airborne particles. Therefore, hoods shall be located as far away as possible from:
  - Doors
  - Supply air diffusers
  - Windows which can be opened
  - Heavy traffic areas
  - Other local exhaust ventilation devices
- C. Room air current velocities at the face of the hood should not exceed twenty linear feet per minute (LFM) from any source and should be as close to zero as practicable.

##### **3. Hood Design and Construction**

- A. General: In general, all fume hoods should be constructed and contain materials that will permit their planned use to be carried out safely; therefore, their intended use must be known.

## B. Ducts

- 1) Ducts should be constructed of materials compatible with the chemicals being used in the hood. Circular ductwork shall be used.
- 2) Ducts are to be constructed of a non-reactive stainless steel, unplasticized PVC, or have an inorganic ceramic coating. Questions about duct composition should be referred to GMU.
- 3) Fume hoods shall not be manifolded.
- 4) Ductwork shall take the straightest route to the roof, minimizing bends and horizontal runs. Increased distances and bends create resistance to air flow and require larger exhaust motors. When elbows are necessary, they shall have proper center-line radius (one-and-one-half times the diameter of the ducts) to minimize eddying and resistance to air flow. All elbows shall have removable wear plates when operations will involve heavy dust concentrations. Ductwork shall not enter the blower motor on an elbow. Exhaust blower motors shall be located on the roof so that a negative pressure will be maintained in the ductwork and prevent escape of toxic material through holes and cracks in the duct.

## C. Filter Housing

- 1) HEPA or charcoal filters are not required for most routine uses of fume hoods. Install a filter or filter housing only if specified by GMU. Where filters are required, the housing shall be located in the fan room or roof before the blower. The filter housing shall be located to allow for easy filter changing by the bag-in bag out technique. Exhaust fans shall be sized accordingly to handle the increased pressure drop across the filter.

## D. Discharge

- 1) The discharge point must be at a proper height above the highest point of the roof or parapet (10-15 ft.) to reduce air streaming effects of the building. Air shall be discharged vertically with at least 3500 feet per minute stack discharge velocity. The discharge stack should be located in the prevailing downwind direction of air intake point.
- 2) The discharge stack shall be uncapped, straight, and cylindrical. The discharge duct shall overlap the fan ductwork 6" and have a 1" greater diameter, to provide for rain drip discharge. Deflecting weather caps are prohibited on discharge stacks, as they reduce the effective stack height, reduce air velocity, are not effective rain shields, and increase final cost.

- E. Sides: Hood sidewalls shall be 3 1/2 - 6 1/2 inches wide, and shall be properly formed to present a smooth airfoil to the inflowing air. The hood interior lining shall be flush with the sides. These features shall, over the range of the hood's

designed air face velocity, prevent significant eddy currents from circulating air from inside the hood through the plane of the face of the hood.

- F. Sill: A radiused stainless steel sill is required. It shall be installed at the bottom of the hood opening and extend back under the sash. An open area of approximately one inch shall be present under the sill to direct air across the work surface at all sash positions.
- G. Sash: The sash may be vertically or horizontally tracked. Horizontal sash hoods shall have a device to lock the sash in its tracks. Removal of the sash only is possible with special tools or keys. Glass used in the sash shall be at least 7/32" thick combination sheet. The sash shall be securely enclosed in a complete frame, welded and ground smooth at the corners. Stainless steel or a baked on epoxy coat is to be used for the sash frame. Vertical sashes shall be counter-balanced with sash weights, suspended from each side of the sash and shall be easily operated. The sash frame must be held in a stainless steel track and have plastic guides. Sashes shall be anti-guillotine.
- H. Interior:
  - 1) The interior lining of the hood must be resistant to the materials and chemicals to which it will be exposed. Stainless steel is acceptable; suitable compositions, including composition board, must be painted or coated with an impervious sealer such as epoxy paint. The selection of resistant materials must be made through consultation with the GMU Environmental Health and Safety Department.
  - 2) Use of perchloric acid, hydrofluoric acid, and radioisotopes require special consideration as detailed in those sections.
- I. Exterior: Cold rolled steel shall be used for the hood exterior. All parts shall be joined together with screws to allow for dismantling and access for service. After fabrication and before final assembly, all component parts shall be given an acid, alkali and solvent resistant finish on both exterior and interior surfaces.
- J. Frame: The exterior and interior walls of the hood shall be rigidly supported by a full frame.
- K. Working Surface: The hood working surface shall be molded epoxy or stainless steel. It shall be recessed not less than 1/4" deep and have a raised area on all sides. The raised area across the front of the hood shall be at least three inches wide.
- L. Hood Fixtures and Services: All hood services shall be specified by the user. All electric service shall be located on the exterior of the hood. Plumbing services shall be brass, chrome-plated, or acid and organic vapor resistant plastic. All fixtures shall have color coded end caps. All controls for plumbing services shall be located on the hood exterior.
- M. Lighting: Sufficient lighting shall be provided by either fluorescent or incandescent light fixtures at the top exterior of the hoods. The light fixture shall be easily accessible from the outside of the hood, shall be shielded from the hood interior by a laminated or tempered glass panel, and shall be vapor sealed.

- N. Air By-Pass Mechanism: All hoods shall be equipped with an air by-pass mechanism located above the hood face opening. It shall provide an effective sight-tight barrier between the user and the hood interior. By-pass louvers shall be directed upward away from the front of the hood and provide an effective barrier and deflector for flying debris from inside the hood. The by-pass shall control the face velocity as the sash is lowered. The velocity of the air at any sash position shall never exceed three times the open face velocity. The air by-pass shall begin to operate when the sash is one-third to one-half closed.
- O. Plenum and Slot Arrangement: A plenum shall be located in the rear of all fume hoods. It must have at least two but no more than three slots. The lower slot shall be furnished at the working surface level and be locked at 2 to 2 1/2 inches or have the baffle removed entirely. The upper slot shall be located in the upper section of the hood. The opening shall be set at 3/8 to 1/2 inch maximum. A middle slot, if furnished, shall be fixed and have an opening no greater than 2 inches.
4. Exhaust Fans and Ductwork: See Division 15
5. Face Velocity Control System

The fume hood shall be equipped with a device to measure and monitor air flow. At a minimum, the system shall have a visual indicator of the hood face velocity. Additionally, adjustable low flow/caution alarm points with audible buzzer or alarm are recommended. The system chosen shall be approved by REHS.

6. Special Hoods

A. Perchloric Acid Hood

- 1) To safely contain perchloric acid, work requirements in addition to the standard design for fume hoods are specified under this section.
- 2) Materials of construction for the hood and ductwork shall be nonreactive, acid resistant and relatively impervious. Type 316 stainless steel, with welded joints, is preferred. Unplasticized polyvinyl chloride or inorganic ceramic coatings, such as porcelain, are acceptable.
- 3) All interior surfaces of the hood and ductwork shall be smooth and seamless, and constructed for easy cleaning. The work surface shall be smooth and watertight with a minimum of 1/2" dished front and sides and an integral trough at the rear to collect wash-down water. The hood shall be designed to allow easy visual inspection of all interior surfaces.
- 4) Ductwork and Exhaust Fans: Each perchloric acid hood shall have an individual exhaust system (i.e., individual duct to individual fan). The ductwork shall go straight from the hood to the roof with no horizontal runs or sharp turns. "Wash-down" facilities shall be built into the hood and ductwork. An air ejector system or an exhaust fan may be used. An air ejector exhaust system eliminates the possibility of acid reaction with fan components and allows for ease of cleaning. If a fan is used, the blades shall be made of acid resistant metal or a metal protected by an inorganic coating. The fan shall be lubricated with fluorocarbon type grease.

## B. Hydrofluoric Acid Hoods

- 1) Hydrofluoric acid is a highly corrosive agent. Consequently, materials resistant to hydrofluoric acid attack shall be substituted for standard laboratory fume hood construction materials. For hydrofluoric acid, use the standard design specified for fume hoods, supplemented by the following specifications on construction and materials.
- 2) The hood and ductwork shall be constructed of nonreactive materials that are resistant to hydrofluoric acid attack and are relatively impervious. A Portland cement hood interior or other suitable material is recommended. The hood shall be constructed to allow easy visual inspection of all interior surfaces. A transparent plastic sash and PVC ductwork are required.
- 3) Ductwork and Exhaust Fans: Horizontal runs and bends in ductwork must be kept to a minimum. The motor and blower housing shall not have exposed metallic parts.

## C. Radioisotope Hoods

In addition to meeting the standard design specifications for fume hoods, the interior of all radioisotope hoods shall be stainless steel or molded epoxy resin and must form a smooth integral unit. All interior screws shall be countersunk and joints sealed and smooth for ease of decontamination.

## **Eyewash units**

1. Eyewash units shall be installed at or near sinks within the hazardous operations space. Such spaces include wet laboratories, areas where dust is generated, darkrooms and other areas where liquid chemicals are used or handled. Handheld hose type units providing a soft spray of 3-7 gpm at a pressure of 30 pounds per square inch are recommended. These may be mounted bench or on the side of the bench or wall, and should be readily accessible and located in a high area or near the main door. Wall mounted units, pedestal-mounted units; eye/face wash units combination safety shower/eyewash units must provide a soft spray of 3-7 gpm at 30 pounds per square inch of pressure.
2. All eyewash units must flush both eyes simultaneously, the flow must remain on without the use of the operator's hands, the unit must remain activated until intentionally cut off and the nozzles must be protected from airborne contaminants.
3. A sign must be posted to identify the location of the eyewash unit and the area behind or around the eyewash unit must be painted with a bright color. Eyewash-units for non-ADA compliant units should be installed between 2'-9" and 3'-9" from the floor. For ADA compliant stations, for dimension references CABO ANSI A117.1 standards for drinking fountains shall be followed. However, the appliance shall be eyewash units.

## **Safety Showers:**

1. Safety showers are to be installed in a conspicuous location, within the space generating the requirement. They must be within the room or space they serve. Safety Showers in corridors should be recessed into the corridor wall as much as possible to avoid pedestrian traffic interference and can serve several laboratories or rooms. Safety showers must be installed in locations that are clearly marked and accessible at all times.
2. Safety showers are to be installed so that the center of the shower head is at least 25” from the nearest wall, bench or furnishing and at a safe distance away from electrical equipment or outlets. The base of the shower must be between 6’-10” and 8’ above the floor. The shower head should be a deluge-type head, and should be made of plated brass or plastic. The safety shower unit be capable of providing a flow of 30-50 gallons of water per minute at 30 pounds per square inch of pressure. Provide a floor drain at the shower location capable of handling the same amount of water as the shower head and piped to the applicable drainage system.
3. Safety shower activating valves are to be operated by pulling a chain, a cord attached to the valve lever, an 8 inch minimum diameter ring or a triangle connected by a chain or cord to the lever. The lowest point of the ring, triangle or cord should be located no more than 48” from the floor for frontal approach and no more than 54” from the floor for a side approach, and should run within 1-2 inches of a wall or bench. Safety shower activating valves are to be quick-opening, self closing globe valves. A shut off valve accessible via a 6 foot ladder is to be installed for each shower head.
4. A sign must be posted to identify the location of the safety shower, and the area behind or around the safety shower must be painted with a bright color. Exterior safety showers and water supply lines must be protected from freezing.
5. Installation and operation of safety showers and eyewash units must comply with ANSI Z358.1-1990.

**End of Section**

## **Division 12: Furnishings**

### **12300: Manufactured Casework**

#### **12350: Specialty Casework**

##### Wood Laboratory Casework

Materials: All material shall be clear of defects and discoloration. All casework surfaces exposed to view after installation including those behind glass doors shall be Oak. All casework not exposed to view after installation shall be hardwood plywood. Ends shall be oak hardwood plywood, 3/4" thick.

### **12400: Furnishings and Accessories**

1. Building furnishings including, but not limited to desks, chairs, tables, lockers, window treatments, lecterns, etc. shall be identified by the A/E but not included in the building contract.
2. The A/E shall provide to the University minimal specifications and a budget cost estimate for furnishings specified to be owner furnished.

#### **12480: Rugs and Mats**

##### Entrance Mats

1. GMU provides "walk off" mats and shall be of the type which are easily picked up and moved for cleaning purposes. Mats should be recessed pedigrid wherever possible.
2. Design entryways to accommodate GMU provided mats.

#### **12490: Window Treatments**

Horizontal blinds are preferred over vertical blinds. The A/E should allow for blinds in designing window heads, including but not limited to blocking. Only blinds which are lead free shall be specified.

### **12500: Furniture**

1. Building furnishings including, but not limited to, desks, chairs, tables, lockers, window treatments, lecterns, etc. shall be identified by the A/E but not included in the building contract.
2. Identify furniture of a higher quality than laminated.
3. The A/E shall provide to the University minimal specifications and a budget cost estimate for furnishings specified to be owner furnished.



## 12560: Institutional Furniture

### Laboratory Furniture

1. Furniture should be approved for laboratory work, i.e. chemical resistant, impervious and easily cleaned.
2. As a general rule, desks are discouraged in laboratories. When required, desk locations should be carefully selected to prevent accidents, spills or releases of toxic materials from endangering the occupants. Desk space design should be limited to laboratory work only.
3. The following manufacturers are preferred for laboratory furniture: Kewaunee, Fisher-Hamilton, VWR, Duralab, Labconco, NuLab
4. Sheet Metal furniture:
  - A. Materials: sheet steel, cold rolled furniture stock. All gauges shall be U. S. standard.
  - B. Gauges: drawer bodies, shelves, interior door panels, security panes, sloping tops shall be 20 gauge. Ends, backs, case tops and bottoms, bases, exterior door panels, and vertical posts shall be 18 gauge. Top front and intermediate rails, gussets, table legs, frames, leg rails, and stretchers shall be 16 gauge. Drawer suspensions, door and case hinge reinforcements, and L-shaped front corner gussets shall be 14 gauge. Table leg corner brackets and leveler gussets shall be 11 gauge.
  - C. Construction:
    - 1) All exposed welds shall be polished smooth.
    - 2) Base units which are 3' and greater shall not have center support posts, cupboards to open full width. All units shall have adjustable leveling screws which can be accessed in the toe base.
    - 3) Drawers shall be full suspension type.
5. Wood Casework: See 12350, Specialty Casework, Wood Laboratory Casework

## **12600: Multiple Seating**

### **12610: Fixed Audience Seating**

Fixed seating, if requested, shall be included in the contract documents and be included in the A/E “design to” budget.

**End of Section**

## **Division 13: Special Construction**

### **13100: Lightning Protection**

Each building shall be considered individually to determine the necessity for lightning protection. The building location, height, proximity and height of surrounding facilities, etc. should be analyzed in determining the need for this protection. If lightning protection is to be provided, it shall be designed and specified to comply with NFPA #780 "Lightning Protection Code" and the completed system and its installation must have a U.L. master label.

### **13110: Cathodic Protection**

Underground steel pipe systems shall be cathodically protected using Pikotec or approved equal.

### **13120: Pre-Engineered Structures**

1. All pre-engineered building specifications shall include a complete listing of structural requirements for the building including, but not necessarily limited to the following:
  - Wind load both horizontal and uplift
  - Snow load
  - Floor loading
  - Mechanical equipment loads
2. Require that the Contractor submit written certification prepared and signed by a Professional Engineer, registered to practice in the Commonwealth of Virginia, verifying that building design meets indicated loading requirements and codes of authorities having jurisdiction.
3. Trailer structures must meet applicable codes for industrial facilities.

### **13200: Storage Tanks**

1. All Installations, Modifications and Upgrades of Underground Storage Tank (UST) Systems shall be done in accordance with the UST regulations.
2. All tanks, steel or fiberglass, if installed shall be as approved by GMU. Tanks shall be installed with anchors, cathodic protection, and leak detection in accordance with manufacturer's instructions. Anchor system and tank beds shall be as approved by GMU.

## 13850: Detection and Alarm

### Fire Alarm Systems

1. Obtain a copy of the standard Fire Alarm system specifications from the Project Manager. Modifications should be made to these specifications to reflect the specific requirements of each project, however, do not change the essence of the document. Ensure compatibility with the existing system(s).
2. Any and all maintenance diagnostic tools, electrical schematic wiring diagrams and any access codes and passwords required to perform any maintenance function over the life of the equipment such as diagnostics, adjustments or reprogramming shall be provided to the Owner on the Date of Substantial Completion. Tools may be handheld or built into the control system and shall function for the life of the equipment without the requirement to return them to the Manufacturer. Provide complete operations and maintenance manuals including diagnostics instructions for troubleshooting the system. The Owner shall not be required to sign licensing agreements related to the use of maintenance or repair tools.
3. It is the intention of the University to obtain competitive bids for maintenance and repair services and material for the fire alarm system provided. Accordingly, the use of proprietary equipment or equipment requiring the use of any proprietary items throughout the life of the equipment is unacceptable. In addition, any special tools, prints, technical data, layouts, hardware, software, etc. required throughout the life of the equipment and which cannot be obtained from multiple suppliers, must be provided by the manufacturer to the Owner at substantial completion of the project.
4. GMU prefers the following systems:
  - a. FCI
  - b. Notifier
  - c. Siemens
5. All smoke detectors shall be photo-electric type including all HVAC duct smoke detectors
6. HVAC duct smoke detectors should maintain power during HVAC equipment shutdown.
7. **Smoke Dampers are not required in any building, on any campus, of George Mason University.**

## 13900: Fire Suppression

1. In buildings with sprinklers, fire pumps and/or standpipes, separate water service for fire protection shall be provided, and shall not be through the domestic metered water service.

2. Provide water curtains in lieu of fire shutters.
3. Control Valves:
  - A. In all buildings with fire alarm systems, all control valves, including post indicator and wall indicator valves, shall be electrically supervised by the fire alarm panel. At all locations that control valves are concealed above ceilings or behind access doors, a sign shall be provided on the ceiling below the valve or the access door indicating the location of the control valve.
  - B. In residential buildings, all control valves that are located in spaces accessible by the occupants of the building shall be provided with lockable tamper prevention devices and locks (that shall be specified by the University).
  - C. Control valves shall only be installed in corridors, stairwells, mechanical rooms, fire pump rooms and sprinkler valve rooms and shall be easily accessible. The control valves shall be accessible with the use of no more than a six foot stepladder. Provide 24" x 24" access door for valves located above inaccessible ceiling types.
  - D. Control valves shall not be installed, above or below ceilings in classrooms, offices, conference rooms or any dormitory living quarters.
  - E. Each control valve shall be supplied with a sign indicating the area of the building that is served by the valve.
4. Inspector Test Valves:
  - A. At all locations that inspector test valves (ITV) are concealed above ceilings or behind access doors, a sign shall be provided on the ceiling below the valve or on the access door indicating the location of the ITV.
  - B. Inspector test valves shall only be installed in mechanical rooms, corridors, stairwells, fire pump rooms, sprinkler valve rooms and custodial closets and shall be easily accessible. The ITV's shall be accessible with the use of no more than a six foot stepladder.
  - C. Inspector test valves shall not be installed, above or below ceilings, in classrooms, offices, conference rooms or in dormitory living quarters or in any area requiring entry through a classroom, office, conference room or any dormitory living quarters.
  - D. Inspector test valves discharge shall be piped to a drain capable of handling the discharge at full flow or to the exterior of the building.
5. Drain Valves:

- A. Drain valves shall only be installed in corridors, stairwells, mechanical rooms, fire pump rooms and sprinkler valve rooms and shall be easily accessible. The drain valves shall be accessible with the use of no more than a six foot stepladder.
  - B. Drain valves shall not be installed, above or below ceilings, in classrooms, offices, conference rooms or in dormitory living quarters, or in any area requiring entry through a classroom, office, conference room or any dormitory living.
6. Main drains discharge shall be piped to the exterior of the building. Auxiliary drain valves discharge shall be piped to a drain capable of handling the discharge at full flow or to the exterior of the building.
  7. All fire protection systems shall be approved by DEB and shall conform to Factory Mutual (FM) standards. All equipment shall bear a FM label where appropriate.
  8. The A/E shall provide a complete set of drawings and specifications which can be approved for compliance with the Virginia Uniform Construction Code by the authority having jurisdiction. The A/E shall design the sprinkler system and provide FM and the University with all calculations.
  9. Reference Standards: Installation of automatic sprinkler systems for fire protection shall comply with the following standards:
    - A. NFPA No. 13, Installation of Sprinkler Systems
    - B. Factory Mutual Data Sheet 2-8N, Installation of Sprinkler Systems
    - C. BOCA National Building Code, the Virginia Fire Protection Subcode
  10. Design Density:
    - A. Design densities for hydraulically calculated sprinkler systems shall comply with the following standards (review with F.M. for any changes):
 

|                         |                                    |
|-------------------------|------------------------------------|
| Classrooms and offices  | 0.15 gpm/sq. ft., 2000 sq. ft area |
| Laboratories            | 0.15 gpm/sq. ft., 2500 sq. ft area |
| Dormitories, Apartments | 0.10 gpm/sq. ft., 3000 sq. ft area |
    - B. Hose stream allowances shall be provided for each system, and shall be not less than 150 gpm for interior hose stream and 250 gpm for outside hose stream. The interior hose stream location, for the purpose of hydraulic calculation, shall be at the hose valve nearest to the riser supplying that floor. In buildings not equipped with a combined fire standpipe/sprinkler riser, the interior hose stream allowance may be deleted.
  11. Flow Velocity: The maximum permissible flow velocity through automatic sprinkler piping shall be 20.0 feet per second.

12. Minimum Pressure: The minimum starting pressure at the most remote sprinkler head shall be not less than 7 psi.
13. Test Connections - Each water flow indicator shall be provided with an Inspector's Test Connection, consisting of a test pipe of not less than 1" diameter terminating in a smooth bore corrosion resistant orifice giving a flow equivalent to one sprinkler head of the type installed on the system. Test connection shall discharge to the building exterior. The 1" control valve for the Inspector's Test Connection shall be located not more than 7' above finished floor. An alternative arrangement for the Inspector's Test Connection is the "Testmaster", manufactured by the Victaulic Corporation.
14. Equipment Type Acceptance: All sprinkler heads, valves, fittings and appurtenances shall be Factory Mutual approved types and shall bear the Factory Mutual acceptance label. All main control valves shall be provided with tamper contacts for connection to the building fire alarm system.
15. Hydraulic Design Submittal: In addition to the distribution of drawings specified in General Conditions, the University shall be provided with one set of shop drawings depicting the complete automatic sprinkler system. Shop drawings shall clearly identify the hydraulically remote area, and all reference nodes shall be included from the supply to and including the remote area. In addition, one complete set of hydraulic calculations, including detail and summary sheets, shall also be submitted for retention by the University.
16. Inspections and Tests:
  - A. All new systems shall be hydrostatically tested at not less than 200 psi pressure for 2 hours. The test pressure shall be read from a gauge located at the low elevation point of the individual system being tested. The inside sprinkler piping shall be installed in such a manner that there will be no visible leakage when the system is subjected to the hydrostatic pressure test.
  - B. All sprinkler heads, valves, fittings and other appurtenances shall be installed prior to conducting the final hydrostatic test which shall be witnessed by the University Facilities Construction Inspector or authorized designee.
  - C. A Contractor's Material and Test Certificate for Aboveground Piping shall be completed and submitted, by the Contractor, to the University Facilities Construction Office and Factory Mutual Engineering.
17. Hydraulic calculations shall be based on approved flow tests which will be performed by GMU. All hydraulic calculations shall be reviewed by Owner and Factory Mutual.
18. Hydrants: see section 02080.
19. Standpipes shall be wet type without hose cabinets. Provide 2 1/2" x 1 1/2' removable valve capped connection at each floor.

20. Where dry or preaction systems are required, use standard wall galvanized pipe as approved by Factory Mutual. Preaction systems shall be used only when approved by the GMU Fire Marshal. These systems are not preferred.
21. Fire pumps on low rise buildings (buildings less than 3 stories) should not be used.
22. Buildings covered by BOCA high rise code in seismic areas shall be designed with a secondary source of water (10,000 gallon capacity or as required) and shall be as approved by Factory Mutual.
23. All fire pumps and sprinkler supplies from city water services shall be installed per city requirements. A/E must contact and coordinate with city officials and design all installations in accordance with their requirements.
24. Do not provide fire hoses. Also, all fire extinguishers will be provided by GMU.
25. Plain end pipe couplings should not be used in systems unless they are the positive locking type specifically approved by Factory Mutual for above ground sprinkler piping.
26. The design area for gridded sprinkler systems shall be the hydraulically most demanding "rectangular area" having a dimension parallel to the branch lines equal to 1.4 times the square root of the area of sprinkler operation corresponding to the density used.
27. To facilitate flushing of the sprinkler system, the ends of all cross mains should be provided with a threaded flushing connection no more than 2" in diameter.
28. Pipe hanger installation shall be in accordance with Factory Mutual Data Sheet 2-8N (NFPA #13).
29. A permanent placard should be provided at the base of each riser stating the design criteria of the system for hydraulically designed systems.

**End of Section**



## ***Division 14: Conveying Systems***

### **14200: Elevators**

See the Construction and Professional Services Manual (CPSM) section 714.

1. Perform work in accordance with the following:
  - ANSI A117.1 Specifications for Making Buildings and Facilities Accessible to and Usable by Physically Handicapped People.
  - ANSI/ASME A17.1 – Safety code for Elevators and Escalators.
  - ANSI/UL 108 – Fire Tests of Door Assemblies
2. All elevators shall meet the requirements of the Virginia Barrier Free Sub code.
3. The following are University approved elevators:
  - Dover Elevator
  - Otis Elevator
  - Schindler
  - Esco Elevators, Inc.
4. Electrical provisions for elevators:
  - a. Power wiring shall be run to the elevator line terminals and a circuit breaker line switch provided adjacent to elevator controller.
  - b. An emergency circuit to mid-point of the hoistway shall be provided in each elevator pit.
  - c. A light, light switch and convenience duplex receptacle shall be provided in each elevator pit.
5. Submittals:
  - A. Require the Contractor to provide, at completion of installation, as-built installation information on reproducible mylar drawings indicating the control wiring, motor data, and all pertinent elevator information necessary for maintenance purposes.

- B. Submittals shall include shop drawings, schematic wiring diagram, product data and maintenance manuals.
- C. Maintenance manuals are required and shall minimally include operating and maintenance instructions, parts listing, recommended parts inventory listing, purchase source listing for major and critical components, and emergency instructions. Provide two sets of maintenance manuals for the Owner's use after approval of all shop drawings.
- D. Contract documents shall require a letter from the elevator manufacturer (on manufacturer's letterhead) verifying that the manufacturer acknowledges and will comply with all requirements of the specifications relative to repair and maintenance tools. Specifically, the letter shall include language that acknowledges the acceptance of the following:
  - 1) Any and all maintenance diagnostic tools, electrical schematic wiring diagrams and any access codes and passwords required to perform any maintenance function over the life of the equipment such as diagnostics, adjustments or parameter reprogramming shall be provided to the Owner on the Date of Substantial Completion. Tools may be handheld or built into the control system and shall function for the life of the equipment without the requirement to return them to the Manufacturer. Provide complete operations and maintenance manuals including diagnostics instructions for troubleshooting the microprocessor system. The Owner shall not be required to sign licensing agreements related to the use of maintenance or repair tools.
  - 2) It is the intention of the Owner to obtain competitive bids for all maintenance and repair services and material for the elevator provided. Accordingly, the use of proprietary equipment or equipment requiring the use of any proprietary items throughout the life of the equipment is unacceptable. In addition, any special tools, prints, technical data, layouts, hardware, software, etc. required throughout the life of the equipment and which cannot be obtained from multiple suppliers, must be provided by the manufacturer to the Owner at substantial completion of the project.
- 6. All key switches used in the hallway or inside the elevator should be on the University master key system. An exception is the emergency fire key which shall be Chicago Key Way H2389. Twelve copies of the key shall be provided to the GMU Physical Plant for distribution to the appropriate department(s).
- 7. Hydraulic Elevators
  - A. Require double wall hydraulic piston casings on hydraulic elevators with waterproof seals at pit floor, and with waterproof, high pressure seal at bottom of casings.
  - B. Jack cylinder shall be installed inside a PVC pipe. (The PVC jacket is helpful in preventing corrosion to the jack cylinder which shall be provided with dielectric protection. If the jack leaks underground, the PVC jacket helps to contain the hydraulic oil).

- C. Install piping above ground where possible. If necessary to route underground, cover with permanent protective wrapping before backfilling. Provide shut off valve in machine room for maintenance purposes. Underground hydraulic piping for elevators shall be schedule 80.

8. Control System:

- A. The elevator manufacturer / vendor shall provide a new control system with all required functions including, but not necessarily limited to call allocation, logic functions, door control, speed sensing / position, all with microprocessor operation. The control system shall not require the use of any proprietary or specialized manufacturer diagnostic tools for purposes of trouble shooting and / or repair. No hand held tools (data entry devices) will be acceptable for diagnostic or adjusting use. The manufacturer will turnover to the University all tools / devices required for the maintenance of the elevator including equipment to reprogram software source codes at no extra cost to the University at the completion of the project.
- B. All software, diagnostic, adjustment / tune-up manuals and documentation and any other documentation required for the maintenance of the elevator including tools or devices necessary to reprogram the software source codes shall be provided to the University for approval prior to commencement of the installation of the elevator equipment. Once provided, no substitution of the equipment described in the manuals and documentation will be acceptable.
- C. All printed circuit boards shall be available to the University for purchase as spare parts in any quantity deemed reasonable by the University. Overnight delivery of printed circuit boards must be available for emergency repairs. Printed circuit boards will be accompanied by all pertinent documentation for installation and use. All components of the elevator must be commercially available from standard parts suppliers.

9. Warranty and Maintenance

- A. Elevator manufacturers shall provide a one-year warranty for all service and maintenance during a one-year period after acceptance. Require the Contractor to submit monthly service reports to the University during warranty period.
- B. Full maintenance shall be provided by skilled, competent employees of the elevator Installer for a period of 12 months following Date of Substantial Completion at no additional cost to the Owner. Full maintenance services to be included under this contract and at no additional cost to the Owner shall minimally include (1) monthly preventive maintenance performed during normal working hours, (2) repair or replacement of worn or defective parts or components, (3) lubricating, cleaning, and adjusting as required for proper elevator operation in conformance with specified requirements and (4) 24-hours-per-day, 7-days-per-week emergency callback service. Exclude only repair or replacement due to misuse, abuse, accidents, or neglect caused by persons other than Installer's personnel.

C. Response times:

- a. Traps - 1 hour
  - b. Repairs – 2 hours
10. Install a ladder, stop switch, a light and a sump pit in the elevator pit. Sump pump (provided under Division 15) may be required where there is a problem with water.
  11. Provide a malfunction signal to the controller which will indicate when the elevator is out of order. The University will take the responsibility of transmitting this signal from the controller to its emergency maintenance system. Auxiliary contacts shall be provided by the Contractor to achieve this function.
  12. If the elevator is a hydraulic elevator, the motor starters shall be one size larger than recommended due to their frequent starting and stopping.
  13. The design of hydraulic elevator machine rooms should be such as to provide for proper environmental conditions to prevent overheating or congealing of the oil.
  14. When elevator machine rooms are adjacent to offices and/or classrooms, provide adequate sound insulation.
  15. Provide security mirrors in all passenger elevator cabs.
  16. Provide elevator access to penthouse mechanical spaces.
  17. Contractor to provide cab protective pads.
  18. Telephone
    - A. All passenger elevators shall have an emergency speaker phone, as manufactured by Rath-Micro Tech or approved equal.
    - B. The emergency telephone will be furnished by the Owner. A 6" x 8" recessed cabinet with door, between 19" and 48" above the cab floor, shall be indicated on the shop drawings. Conduit for the telephone shall be installed by the contractor.
    - C. Provide conduit for analog telephone wiring from the telephone backboard to the elevator controller. Power for the elevator telephone must be on an emergency circuit.
  19. Elevators shall be integrated with the fire detection system and contain both an ADA compliant visual alarm device, and an automatic return to lobby and shutdown feature in the event of fire detection.
  20. Elevators shall have vandal resistant controls and finishes such as heavy-duty stainless steel finish on panel and hard-to-damage cab wall treatment. Residence Hall elevators

shall have stainless steel cab interiors and vandal resistant hall call stations, light fixtures, car stations, position indicators, etc.

21. Prior to Owner acceptance of the installation, an inspection must be performed and acceptance tests must be witnessed by an independent elevator inspector to verify conformance of elevators and chair lifts with code requirements. The Owner shall employ the services of an independent elevator inspector. Any deficiencies shall be corrected by the contractor at no cost to the Owner. Owner requires three weeks notification prior to testing to schedule inspector.
22. Elevator equipment rooms shall not be used for access to roofs or other parts of the building unless elevator equipment is fenced or walled in.
23. Traction-type elevators shall have machinery located overhead.
24. Elevator pits shall have sump pumps and adequate drains to prevent the accumulation of water. Drains shall not be connected to building sewers.
25. Elevator cab floors shall be rubber floor tile with "lo-disc" raised circular design for a non-slip surface. Acceptable manufacturers include Roppe Rubber Co., Johnsonite and Musson Rubber Co.
26. Provide a sweep on the machine room door to provide of dust protection.
27. Provide all signage as required by applicable codes.
28. Elevators shall be provided with a full ray electronic door detection device. Device shall project detection beams across the full car entrance from the floor to a 72 inch minimum height. When interrupted at any point, the device shall cause closing doors to stop and reopen and enact an alarm buzzer. The doors shall again attempt to close unless the detection beam is activated in which case the doors will reopen. The process shall repeat continuously until the obstruction is removed from the entrance. Provide a keyed switch in the car operating panel or a toggle switch in the service cabinet that will disconnect the electronic detection device.

## **14400: Lifts**

### **14420: Wheelchair Lifts**

Chairlifts shall require keys for operation.

## End of Section

### ***Division 15: Mechanical***

#### **15000: Mechanical General Requirements**

1. See the Construction and Professional Services Manual (CPSM) section 715.
2. This Section must be coordinated with the General Conditions. Do not address items such as handling of shop drawings, maintenance manuals and other information contained in the General Conditions or written in Division 1.
3. Coordination drawings should be prepared at a scale of  $3/8" = 1'-0"$ .
4. Energy and resource conservation effectiveness shall be considered and documented. The GMU Fairfax Campus operates a Central Heating and Cooling Plant (CHCP) to supply campus buildings. New buildings are to be tied into this system wherever possible.
5. All equipment shall be installed with sufficient walk-around room to insure proper maintenance of equipment. Equipment shall be installed such that tube pull, filter replacement, ease of removal and replacement of strainers, ease of draining equipment, filter changes, convenience for service of parts, etc. can be achieved.
6. For all new construction, renovations and alterations, the Contractor shall mark-up the contract documents to indicate any changes in construction and installation due to field conditions or other deviations from the plans and specifications. The A/E shall take the record drawings and produce the As-Builts on mylar with a CAD file.
7. The A/E shall be responsible for preparation and follow-up correspondence for all permitting required for fuel burning equipment.
8. Supply Air Requirements: At a minimum, outside air must be supplied to occupied spaces in accordance with ASHRAE 62-1989, Ventilation for Acceptable Indoor Air Quality. All laboratories, shops and studios where hazardous materials are used must be maintained under negative pressure with respect to areas of lower hazard (e.g. corridors, offices). Exhaust air from these areas of higher hazard must not be recirculated, and must be exhausted directly to the outdoors. Air intakes must be located in areas where they not introduce air pollutants into the building (e.g. away from loading docks, high traffic areas, emergency generator exhaust and exhaust from other buildings, etc.)
9. No roof top mechanical equipment shall be located closer than  $10'-0"$  to a roof edge unless adequate guardrail protection (rail or parapet) is provided.

10. HVAC - Temperature Design Standards: see the Construction and Professional Services Manual (CPSM) section 715.A.2.

|                | Winter   | Summer            |
|----------------|----------|-------------------|
| Arlington      | 7° F DB  | 91° F DB/77° F WB |
| Fairfax        | 7° F DB  | 91° F DB/77° F WB |
| Prince William | 10° F DB | 93° F DB/77° F WB |

For cooling towers, use 78° F WB design.

11. Sealants shall not take the place of welding of metal ducts.
12. Access for mechanical device installation, operation, and future maintenance is essential. Provide access doors for all VAV boxes. When access doors are specified, check with the Project Manager for need of locks.
13. Field verify HVAC system CFM values in existing buildings prior to renovation designs.
14. Encase all cleanouts and valve boxes located in lawn areas in a 1' x 1' x 6" concrete pad.

## **15050: Basic Mechanical Materials and Methods**

### **15060: Hangars and Supports**

1. Provide calculations for pipeline flexibility. Anchor as needed. Conform to ASME Code for allowable stresses. Furnish calculations for spring hangers. For ductile iron/glass piping for sterilizer/autoclave uses ensure pipe hanger supports prevent any lateral movement.
2. All piping with insulation shall be supplied with saddles and rigid insulation at pipe hanger locations.
3. Seismic requirements must be considered as required.
4. Provide extra pipe supports for sterilizer piping.

### **15075: Mechanical Identification**

1. Mark location of air handlers, fan coil units, mixing boxes, etc., above ceilings with identifying "buttons" to facilitate maintenance through ceiling.
2. Tag roof top exhaust fans and associated fume hood to facilitate maintenance and identification.
3. Utilize standard tag or placard to mark all major equipment. Tag all valves and provide valve chart for each floor.

4. Utilize standard Commonwealth of Virginia color coding for various building service piping and ductwork. Mark each with name of service, direction of flow, and associated unit served where appropriate.
5. All systems handling hazardous materials must have appropriate marking and visual or audible alarms to protect building occupants and maintenance personnel. Mark exhaust fans on roof which handle hazardous fumes with appropriate color code.
6. Mark air handling units with large letters and numbers.
7. All fire dampers shall be numbered and identified on chart in mechanical room.
8. Provide strap-on markers for pipe. Pressure-sensitive type markers are not acceptable.
9. Conform with ANSI 13.1

#### **15080: Mechanical Insulation**

1. All insulation shall conform to Energy Code.
2. Staples are not acceptable for insulation installation.
3. All "raw" ends of insulation shall be sealed.
4. For High Temperature Hot Water insulation (greater than 400° F.) use 4" calcium silicate.
  - a. For interior piping: canvas wrap, coated with Fosters 81-42w or equal and painted to match existing supply and return piping.
  - b. For tunnel piping: wrap with an approved non-flammable moisture barrier. Aluminum jacket preferred.
5. Insulation specification shall describe what systems and services are to be insulated.
6. Internal insulation on ductwork is prohibited unless approved by GMU.

#### **15100: Building Services Piping**

1. All welding of high temperature water systems shall be performed by welders certified in accordance with ASME Boiler and Pressure Vessel Code, for pressure piping, latest edition.
2. The HTHW tunnel shall be separated from the mechanical space in the building by a removable solid steel or aluminum plate to keep heat, water vapor, etc. from entering the mechanical space and damaging equipment. Ensure the plate can be easily removed from



the mechanical room, for servicing, and the tunnel side as a means of escape in case of emergency.

3. Design tunnel and piping with as little abrupt elevational and lateral direction change as possible to avoid additional anchorage and expansion joints. Tunnel height can vary with site contour but height shall not exceed 8’.
4. See Part V – Standard Details, [HTHW Tunnel Detail, Fairfax Campus](#), [HTHW Tunnel Top Details](#), [HTHW Manhole Detail](#) for information on HTHW tunnel and piping clearances.
5. Encase all key crocks, for chilled water building isolation, in a 1’ x 1’ x 6” concrete pad.
6. Do not run plumbing piping above telecommunication racks.

### **15105: Pipes and Tubes**

1. USA made materials are preferable.
2. "Victaulic" pipe will be allowed for condenser water and chilled water at equipment connections only.
3. Materials for High Temperature Water Systems:

#### A. Pipe:

| 2" and Larger      | 1-1/2" and Smaller         |
|--------------------|----------------------------|
| Schedule 80        | Schedule 80                |
| ASTM A 53, Grade B | ASTM A 53, Grade B         |
| Black              | Black                      |
| Seamless           | Electric Resistance Welded |

#### B. Fittings

| 2" and Larger      | 1-1/2" and Smaller  |
|--------------------|---------------------|
| Schedule 80        | 3,000 pound         |
| Seamless           | Forged Carbon Steel |
| Butt-welded type   | Socket weld         |
| ASA B 16.9         | ASA B 16.11         |
| ASTM A 234 Grade B | ASTM A 105 Grade II |

Weld ells shall be long-radius pattern.

- C. Flanges (all sizes): 300 pound class, forged steel, welding neck type, ASA B 16.5 ASTM A 181 Grade I.

- D. Gaskets (all sizes): Spiral wound, type 304 stainless steel, non-asbestos filled, 3/16" thick with centering guide, 300 pound class, by Garlock, Flexitallic style CG, or approved equal.
  - E. Strainers (all sizes): Y-type; same size as pipe in which they are installed. Strainers shall have cast steel bodies suitable for 425° F temperature and 600 psig pressure, bottoms drilled, directional arrow on body. Strainers shall be equipped with easily removable cover and basket. Basket shall be stainless steel with 3/32" perforations. Net free area through back of basket shall be 2-1/2 times the area of connecting pipe. Flow shall be into basket and out through perforations.
  - F. Unions (normally not to be used on pipe larger than 1"): 3,000-pound class forged steel, socket-welded type, with steel to steel seat, ASTM A 105 Grade II, as manufactured by Henry Vogt Machine Co. or approved equal.
  - G. Welding Rings (to be used on pipe 4" diameter and larger): Carbon steel with knock off spacer pins, for Schedule 40 and/or Schedule 80 pipe dimensions.
  - H. Bolts and Studs: Alloy steel studs threaded full length and fitted with two hexagon nuts per stud for all flanged joints. Bolting to conform to ASTM A 193 Grade B-7, threads class 7 fit. Nuts shall be semi-finished hexagonal, ASA B 18.2 ASTM A 194 Grade 2H.
4. Dielectric fittings shall be used with connecting piping of dissimilar metals.

### **15110: Valves**

1. USA made materials are preferable.
2. Include sufficient zone isolation/shut off valves in cold/hot water, heating hot water, chilled water, steam and other service piping to allow maintenance and replacement of terminal equipment without shutting down entire building.
3. Install valves on all lines that penetrate the floor from below.
4. Install valves on all branch lines off of main lines.
5. Install valves on all lines at locations such that each floor can be isolated independent of main building.
6. Any equipment such as showers, darkrooms, etc., requiring mixing of hot and cold water shall utilize a solid brass pressure compensated mixing valve rather than a temperature compensated mixing valve.
7. Install control valves where they can be reached from the floor where possible.

8. Chain-wheel operators for valves above 7 ft. shall be located in a place where they will not interfere with normal access and shall be restrained at wall or column if necessary.
9. OS&Y valves are preferred. Butterfly valves shall be Lug type, with memory stop and shall have EPDM (or better) seats.
10. Valves for High Temperature Water:
  - A. 2" and Larger: Shall be OS&Y type of the ASA 300 pound class, cast steel body, 13% Cr. stainless steel trim, flanged at connections to equipment, flanged at other than equipment connections, bored to match inside diameter of pipe.
  - B. 1-1/2" and Smaller: Shall be of ASA 600 pound class, cast steel or forged carbon steel, socket weld pattern, 13% Cr. stainless steel trim, bored to match inside diameter of pipe.
  - C. Gate Valves: Shall be solid wedge with stainless steel wedge or wedge faces, stainless steel seat rings. Stainless steel bonnet bushings and beveled collar on valve stem for back seating. Provide braided, teflon impregnated backing rings in a large, deep stuffing box suitable for high temperature water service. Insert at bottom of stuffing box, to serve as base for packing. Packing glands shall be non corrosive and shall have bolted gland flange with minimum of 2 eye bolts. Valves, with their bypasses, need to be installed for proper operating access.
    - 1) Gate Valves 1-1/2" and Smaller: Provide with a minimum of 4 packing rings.
    - 2) Gate Valves 2" and Larger: Provide with a minimum of 6 packing rings.
    - 3) Gate Valves 6" and Larger: Provide with a minimum of 6 packing rings. Provide forged steel, globe valve bypass, minimum 3/4". Provide with tapered roller or ball bearing yokes and button type grease gun fittings and adapters to allow charging a reservoir with valve lubricant.
    - 4) Gate Valves 8" and Larger: Provide with a minimum of 6 packing rings. Provide forged steel, globe valve bypass, minimum 3/4". Provide with tapered roller or ball bearing yokes, bevel gear operators, clockwise rotation to close, lamenated lubricating fittings and approved grease seals.
    - 5) Acceptable manufacturers: Crane, Jenkins, Vogt.
  - D. Globe and Angle Valves: Shall be of the cast plug disc with bevel seat, separately screwed or pressed in disc and seat rings, long disc locknut, port opening full pipe diameter. Provide stainless steel seat ring and disc: stainless steel bonnet bushing and beveled collar for backseating. Provide braided, teflon impregnated packing rings in a large, deep stuffing box suitable for high temperature water service. Insert a bottom of stuffing box to serve as base for packing. Packing glands shall be non-corrosive and shall have bolted gland flange with minimum of 2 eye bolts. Valves with their bypasses shall be installed for proper operating access.

- 1) Globe & Angle Valves 1-1/2" and Smaller: Shall have minimum of 4 packing rings.
  - 2) Globe & Angle Valves 2" and Larger: Shall have minimum of 6 packing rings.
  - 3) Globe & Angle Valves 6" and Larger: Shall have minimum of 6 packing rings. Valves shall have forged steel, globe valve bypass; button-type grease gun fittings and adapters to allow charging a reservoir with valve lubricant tapered roller or ball bearing yokes.
  - 4) Globe & Angle Valves 8" and Larger: Shall have minimum of 6 packing rings. Valves shall have forged steel, globe valve bypass; button-type grease gun fittings and adapters to allow charging a reservoir with valve lubricant; and tapered roller or ball bearing yokes. Shall be equipped with impactor or hammer-blow hand wheel.
  - 5) Acceptable manufacturers: Crane, Jenkins, Powell, Vogt.
- E. Check Valves: Shall be horizontal swing check, 300 lb. cast steel, with 13% Cr. stainless steel disc, disc face and barrel type seat rings. Provide full port opening. Disc and seat shall be removable without removing valve from line. Acceptable manufacturers: Crane, Jenkins, Powell, Vogt.
- F. Gage and Instrument Valves: Shut-off valves for pressure gages and instrument isolating valves shall be of the "barstock" construction, with stainless steel body and stainless steel plug type disc integral with stem. Ends shall be I.P.S. screwed. Rating shall be 600 psig at 7500F. Valves shall be 1/2" size, Crane Co. or approved equal.
- G. Blowdown Valves: Blowdown valves for cascades, expansion drums, hot water generators shall be unit-tandem type valves, consisting of one hardseat and one seatless valve in one common steel body to conform to the ASME Boiler Code. Valves shall be rated at 400 psig and suitable for pressures to 665 psig. Valves shall have welding ends and alloy steel trim.
- H. Needle Valves: For high temperature water convectors shall be of "barstock" construction with stainless steel body and stainless steel plug type disc integral with stem. Ends shall be I.P.S. screwed. Rating shall be 600 psig at 7500F. Crane Co. or approved equal.
- I. Drain and Vent Valves: Drain and vent valves shall be ASA 600-pound class 1 forged steel globe or angle valves, as specified above. Drain valves need to be sized and shown on the Drawings. Unless otherwise required, vent valves shall be 1/2" size.
- J. Control Valves: Flanged 300 lb. cast steel, 316 stainless steel trim, Fisher Type ES body with pneumatic 667 actuator. Valves 1-1/2" should not require a

positioned; valves larger than 1-1/2" should have a positioner. Use equal percentage contour plug. Preliminary sizing shall be based on 20 psi. pressure differential (verify with Project Manager). Valves shall be capable of closing off against a 100 psi pressure difference.

11. Drain valves shall be installed in accessible locations at all low points in the piping system to permit drainage and servicing.

## **15120: Piping Specialties**

### Sleeves

Do not use sheet metal sleeves through outside walls. Sleeves shall be pipe conforming to ASTM A 120. At outside walls provide "leak plate" and install "Linkseal".

### Expansion Compensation

1. Avoid using expansion compensators on Secondary Heating Water if possible. Use expansion bends (calculated) for pipe flexibility situations. If space is limited, bellows type can be used if approved by GMU.
2. Do not use bellows type expansion joints on HTHW. Flanged, slip type expansion joints are preferred.

### Meters and Gages

1. Provide differential pressure indicator (manometer) for all serviceable filters and locate the indicator where it can be readily observed. Mark on the indicator the "clean" and "replace filter" points.
2. Use bimetallic temperature indicators in 5" diameter case. Orient gage so that special flexible joint is not needed.
3. Use materials compatible with service for pressure indicators, temperature indicators and flow meters. Use diaphragm where needed.
4. Water Meters shall be included in the contract and installed in accordance with the City of Fairfax specifications.

## **15130: Pumps**

## HVAC Pumps

1. Consult with GMU about pump selection philosophy. Limit speed to 1750 RPM. Any pumps handling HTW shall be selected with GMU's input. Industrial pumps may be required.
  - A. For small flows and low heads, in-line circulators may be used, this application is limited to zoned residential-type (or similar) systems and may include systems intended to prevent cold freeze-up. Typical limits are 80 GPM at 25 feet TDH.
  - B. Vertical in-line pumps may be used for systems similar to those described in the paragraph above where a larger system head exists. Typical limits are 3", 7-1/2 HP.
  - C. Base-mounted close coupled and separately controlled, end suction pumps shall be used when flows are between 100 and 500 GPM. The suction connection should be less than 4". Close coupled pumps should not exceed 10 HP and should not exceed 15 HP for the separately coupled pump. Base mount or separately coupled pumps should be of the back pull-out type.
  - D. Base-mounted, separately coupled double-suction, horizontal split-case type pumps should be used for connections 4" and larger. B&G VSC may be used. Consider vertical pumps, such as Aurora 413, where space is at a premium.
  - E. Selection should be made for high efficiency. Consideration of life cycle cost study of variable speed pumping should be made.
  - F. Use mechanical seals when choice is available. Use cyclone separator type seal waste cleaning device on all pumps that can be equipped with it (generally on all double suction pumps).
2. Vibration control is usually not needed when pumps are mounted on basement slab. All vibration controls need to be carefully examined. Pads, isolated from the slab may be acceptable. Inertia blocks need to be considered when the pump room is below an acoustically important room. Flexible connectors should also be minimized in use.

### **15140: Domestic Water Piping**

Provide frost proof wall hydrants every 50' on exteriors of new buildings. Model B65 series as made by Woodford Manufacturing, Inc. or approved equal.

### **15150: Sanitary Waste and Vent Piping**

1. Do not use plastic pipe materials above ground.
2. Hubless cast iron pipe is acceptable above grade (not acceptable below grade).

3. Install floor drains in all restrooms, centrally located with floor slightly sloped toward drain, 6" inlet with 2" outlet, chrome plated brass or nickel bronze.
4. Drain and waste lines in laboratories shall be selected for chemical resistance **and** for resistance where steam is used as a laboratory medium.
5. Encase all cleanouts and valve boxes located in lawn areas in a 1' x 1' x 6" concrete pad.

### **15160: Storm Drainage Piping**

1. Provide at least 2 roof drains per section of reel. See Uniform Construction Code for additional requirements.
2. Encase all cleanouts located in lawn areas in a 1' x 1' x 6" concrete pad.

### **15180: Heating and Cooling Piping**

#### Hydronic Piping

1. Medium temperature water systems are designed at 190° F. Use 150# AISI design standards.
2. High Temperature Hot Water systems are designed at 450° F. and 300 psig, depending on campus: use 300 Lb. ANSI design standards. Use a 100° F delta.
3. Chilled Water systems are designed at 42° F to 55° F. nominal temperatures. Use a 14° F. delta.
4. Dual temperature systems shall be designed for 100-190° F., winter and 42° F to 55° F summer. Use A. O. Smith "green thread" or approved equal.
5. 4-pipe systems are preferable.
6. GMU prefers diaphragm-type compression tanks.
7. Triple duty valves are not acceptable.
8. Steel and copper pipe can be used for hydronic piping. Do not use plastic piping.
9. Flexible connection shall be installed at pumps only when directed by GMU or when acoustic consultant recommendations are accepted by GMU.
10. Hanger spacing for copper pipe shall be as follows:

| Pipe Size | Hanger Spacing |
|-----------|----------------|
| 1"        | 6 ft.          |
| 1-1/2"    | 8 ft.          |
| 2"        | 9 ft.          |
| 3"        | 10 ft.         |
| 4"        | 12 ft.         |

11. Do not use butterfly valves for throttling hydronic systems.

### Steam and Condensate Piping

1. Steam system shall be designed for low pressure (15 psig or less) unless otherwise approved by the University. When steam is obtained from a HTW steam generator, it is especially important to realize that pressures of 30 psig or greater are difficult to justify because they use an enormous flow of primary HTW. All kitchen equipment (dishwasher, steam tables, etc.) should be operated at less than this pressure. Autoclaves, sterilizers and cage washers should be capable of operating at less than 30 psig steam. If this is not possible, the use of an electrically driven steam generator that can be separately metered (electrically) can be considered.
2. Steam for user-required humidification should be generated by unitary humidifiers, approved by the University, as manufactured by Armstrong, Sarco, Carnes, Herr, Nortec or approved equal.
3. Use bimetallic element traps only with GMU approval.
4. Hot Water is preferred heating medium.
5. Use steel pipe conforming to ASTM A 53, Grade B. Use of copper pipe shall be subject to approval by GMU. If copper pipe is used, modify fittings accordingly.
6. Adjust class of safety valves for pressure and temperature used in each system.
7. Steel piping 1" or less for low-pressure steam shall be Schedule 80.
8. Do not use butterfly valves for throttling steam systems.
9. Sizing of reducing valves shall be clearly shown on the Drawings for all equipment.
10. Pipe discharge from safety valves shall be terminated at a safe height and location to prevent personnel harm.

### **15190: Fuel Piping**

1. Use # 2 fuel oil type systems.



2. University gas systems are natural gas.

## **15300: Fire Suppression Piping**

See section 13900, Fire Suppression

## **15400: Plumbing Fixtures and Equipment**

### **15410: Plumbing Fixtures**

1. All plumbing fixtures shall have water saving type controls.
2. All plumbing fixtures must be tight fitting to walls and be neatly sealed at joint with silicone sealant.
3. Plumbing fixtures and fittings for laboratory furniture shall be provided by the laboratory furniture manufacturer.
4. See Division 11600 for eyewash and safety showers.

#### *Water Closet*

Watersaver vitreous china, wall hung, siphon jet, elongated closet bowl with 1-1/2" top spud with 5-1/4" floor to center outlet equal to Eljer Auburn Watersaver Vitreous China #111-1405.

#### *Drinking Fountain*

1. Not recessed, wall mounted, surface mounted.
2. Provide "lead free" materials certification from drinking fountain manufacturer prior to installation.

#### *Service Sink*

Located in custodial closet. Floor mounted, cast iron or steel with baked enamel covering, acid/chemical resisting plastics, concrete or stone construction material; 28" maximum height from floor to rim, 24" x 24" (minimum size); Faucet - vacuum breaker, integral stops, spout with pail hook and nose end, top single brace, renewable units and valve seats, equal to Eljer.

### **15480: Domestic Water Heaters**

1. Water heaters generally should be heated with HTW or MTW when central heating systems available. Check with GMU for specific requirements. Use 2-way, cast steel control valves as approved by GMU.

2. Other heating media shall be as approved by GMU.
3. All water heaters shall comply with ASME Boiler and Pressure Vessel Code and shall be stamped with appropriate code symbols.
4. Oil fired water heaters shall be used only with GMU's approval.

## **15500: Heat-Generation Equipment**

### **15510: Heating Boilers and Accessories**

1. Cast iron sectional boilers are the preferred boiler for remote locations and relatively small boilers. Use hot water generators when possible. Approved manufacturers are H. B. Smith and Weil-McLain. Buy as a package unit when possible with high-efficiency burners approved by GMU. Comply with all Factory Mutual requirements.
2. Scotch Marine boilers may be considered for installations larger than 50 horse power. They should be multi-pass and have an efficiency of greater than 80% at the design point. Comply with Factory Mutual requirements. Buy a packaged boiler whenever possible. Consult GMU for use of dual-fuel burners for type of burner to use, turn-down desired and type of control to use.
3. Boilers shall be operating at pressures 15 psig or less.
4. Do not use electric boilers except for small outputs which serve a special piece of equipment (5 HP or less).
5. Water treatment should be discussed with GMU.

### **15520: Feedwater Equipment**

Consult GMU's engineers concerning feedwater equipment.

### **15540: Fuel-Fired Heaters**

Do not use without permission of GMU. If so, use less steel heat exchangers that are gas-fired units (not oil fired), using spark ignition only.

### **15550: Breechings, Chimneys, and Stacks**

1. Terminations of chimneys and stacks shall be "open" (without weathercap) so that an upward velocity is possible, without sideward flue gas movement. Design so that velocity of gases will clear any surrounding roofs, building and especially outside air openings. A velocity control device may be necessary at the outlet of the stack.
2. GMU may require an analysis of effluent flume shape and dispersion by a specialist in air wake analysis. Specialist shall be approved by GMU. Such analysis is typical for all discharge stacks such as laboratory fume hood or other laboratory discharges.

## **15600: Refrigeration Equipment**

1. Warranty: 5 year parts and labor on all components including the compressor, fan motors, structural components, etc.

## **15620: Packaged Water Chillers**

### *Reciprocating Water Chillers*

Use only on very small projects, with GMU permission. Water cooled units may be considered for special applications such as back-up refrigeration. Air cooled units must be justified by analysis. Heat recovery units will require an economic evaluation including life-cycle analysis. Refrigerant type to be approved by GMU.

### *Centrifugal Chillers – Water Cooled*

1. In many cases, GMU will pre-purchase centrifugal chillers. GMU requires as efficient a unit as possible. Refrigerant type to be approved by GMU. Centrifugal chillers shall not be located outside of the building. A/E shall indicate pipe rupture disk discharge to a safe point.
2. If the unit is pre-purchased, the A/E shall obtain pre-purchase specifications from GMU.
3. Trane, York or Carrier are approved manufacturers.

## **15640: Packaged Cooling Towers**

1. GMU prefers cooling towers with propeller fan, packaged, cross flow (induced draft) with stainless steel pan. Use a Marley selected for low horsepower, or approved equal. Towers shall have metal Balance Clean Chambers.
2. Centrifugal fan, forced draft towers are to be reviewed with GMU prior to consideration.
3. Winterizing requirements shall be discussed with GMU. The appropriate design shall be reviewed prior to such application.
4. Fan motors shall be 2- speed, controlled and sequenced to obtain the condenser water temperatures needed. Size of conduits to starter located in Mechanical Room shall take this into account.
5. Fan drive shall include a gear box.
6. Provide handrail, ladder and cage for access.

7. Provide flow control valves for all outlets. Provide all needed screens and protective devices. Discharge hoods and sound control measures shall be provided to attain noise levels acceptable to local conditions and ordinances.
8. Float type Water level control is preferable. EP, BD and chemical pump should have H-O-A- selection switch.
9. Provide drains near cooling towers to handle overflow.
10. Warranty: 5 year parts and labor on all components including the fan motors, structural components, etc.

### **15670: Refrigerant Condensing Units**

1. Use only on very small projects, with GMU permission. Water-cooled units may be considered for special applications such as back-up refrigeration. Air-cooled units must be justified by life-cycle cost analysis.
2. Limit air cooled condensers to very small systems or for equipment such as constant temperature rooms unless life-cycle cost indicate otherwise.
3. Where air cooled condensers are used, they shall be designed for low ambient temperature operation.
4. Warranty: 5 year parts and labor on all components including the compressor, fan motors, structural components, etc.

### **15700: Heating, Ventilating, and Air Conditioning Equipment**

#### *Rooftop Heating and Cooling Units*

1. These may be used only with GMU approval. When used, the only acceptable types are:
  - Trane
  - York
  - Carrier
2. When rooftop equipment is suggested for the project, the access to the roof shall be as a minimum a stair tower meeting applicable codes extended full-size to the roof. In addition, an available elevator may be required to extend to the roof.
3. As an alternative, the equipment may be located on an approved ground slab.
4. Coils shall be fully drainable and fin spacing shall not exceed 120 fins per foot as specified for coils in air handling units.

5. Heating and cooling should be from external sources of hot water (or glycol mixture) or chilled water; do not use gas fired exchangers or air cooled refrigerant (DX) systems without GMU approval.

### **15710: Heat Exchangers**

1. Selection and specifications for liquid-to-liquid, steam-to-liquid, air-to-air, etc. shall be reviewed by the University.
2. HTHW heat exchangers shall be shell and tube type. HTHW shall be in tubes. Tubes shall be 90-10 copper-nickel. Heads shall be steel (forged, steel). In water-to-water exchangers, the water flow shall be upward. In water-to-steam generators, the controls shall be similar to those used for fired steam generators, excluding low water cutoff. Provide separate over-temperature control on leaving hot water. Provide required level controls, relief and/or safety valves on water or steam generators. Provide increase tube pitch on steam generators.
3. Provide units with a fouling factor of 0.0005 for water or as approved by GMU. For glycol exchangers, consult with GMU. 30% glycol solution should provide adequate freeze protection; consult with GMU if it is felt that a greater percentage is required. Propylene glycol may be required for certain food handling operations.
4. HTHW-to-water heat exchangers shall have the temperature sensing elements operating plus over temp., located in the shell near the outlet nozzle, and immediately adjacent to outlet nozzle.
5. HW for heating shall be 190° F (or 200° F if approved by GMU).

### **15720: Air Handling Units**

1. HW and CHW coils shall have no more than 120 fins per foot of tube length, where possible. All coils shall be completely drainable at each row. Drainage of coil shall be accomplished by removing the drain and vent plugs; no other means shall be required. Copper tubes with aluminum fins are satisfactory. HW coil temperature drop should be high (50° to 100° F.) with an entering water temperature of 190° F. CHW temperature drop should be 14° F. with an entering temperature of 42° F. For 100% outside air applications, a higher delta T maybe used with GMU permission.
2. Use of factory automatic temperature controls may be considered.
3. Do not use electric heat without specific permission of GMU.
4. Properly locate face and bypass dampers on 100% outside air systems so that no coil will receive a low temperature blast of cold air when bypassed, or provide a properly sized pumped water protective system.

5. Humidifiers should be used only with GMU approval. Use canister type steam generator with proper distributing grid if approval is obtained.
6. 30% Filters shall be installed in manufactured filter frames. Precede higher efficiency filters with roughing filters. Use HEPA or other high efficiency filters when required or directed. Provide pressure differential gage to monitor filter performance on all major air handling units.
7. Condensation drain pans will be stainless steel.
8. Access doors on the return side to open outward. Supply side doors to open inward and be removable if space is limited inside the unit.

### **15730: Unitary Air Conditioning Equipment**

#### **Window Air Conditioners**

Window air conditioning units are not preferred by GMU and should be avoided. If no other options exist, they shall be equipped with a programmable timer which can be shut off when the space is not occupied. The timer can be part of the unit, or at the panel as appropriate.

### **15740: Heat Pumps**

The university encourages investigating water-source heat pumps for feasibility. Use only after detailed life cycle cost analysis and approval of GMU.

### **15760: Terminal Heating and Cooling Units**

1. Use 18 gauge front panels on baseboards.
2. Fan coil units shall have permanent split capacitor motors.

### **15800: Air Distribution**

#### **15810: Ducts**

1. Insure ducts are free of debris before filters are replaced at project close-out.
2. For fume hood duct design and construction, see 11600.

#### **15830: Fans**

1. In-line or tubular fans are not preferred and such use shall be approved by GMU.
2. Drives for centrifugal fans (especially for fume hoods) shall be multi-belt. Generous size pulleys shall be used to reduce the belt bending.

3. Drains shall be provided in fan scrolls, especially when the fan may receive storm water in its ordinary course of duty. This applies to most of the fume hood exhaust fans that use the GMU's preferred vertical discharge stackhead.
4. Fume hood fans shall be nonsparking and Teflon P coated. Wheels and scrolls may be heresite coated for corrosion protection. Use explosion proof motors when required.
5. Exhaust fans and duct systems for hoods are to be sized and designed to provide an average hood face velocity of 80-100 LFM, as measured at the face, with the sash wide open. Deviations in this value shall not be greater than 20% at any point across the hood face. To assure this standard, the designer must work closely with the duct installer to determine the effects of duct routing on motor sizing.
6. Exhaust fans shall be located on the roof, or in an adequately ventilated fan loft. Exhaust motors shall be located to allow access for maintenance.
7. Do not use backdraft dampers on laboratory fume hood fans unless specifically approved by GMU.

### **15860: Air Cleaning Devices**

Duct Cleaning shall be based upon the National Air Duct Cleaners Association (NADCA) specification.

### **15900: HVAC Instrumentation and Controls**

1. All buildings larger than 5,000 sq. ft., or containing research equipment or other mechanical/electrical gear operating on a continuous basis should be equipped with a Siemens energy management system (EMS) that ties into the existing campus EMS system. This system shall have the capability of monitoring the conditions of the environment within the building for temperature, humidity, and movement; determining the operating status of all environmental control equipment in the building; and changing the status of the equipment to effect changes in the environment inside the building.
2. If the space is greater than 500 s.f. two thermostats or room sensors shall be installed. They will operate either individual units or average to control a single unit.
3. Theromstats or room sensors shall **not** be mounted on the same wall as the entry door to the space. They shall be mounted in the middle of the perpendicular wall which is the farthest from the entry door.
4. In general, the system shall include an electrical or electronic processing unit receiving information on the status of various sensors in the building and comparing this information with standard instructions relayed from a central processor. The local unit then makes changes required according to programming already present in its memory or overridden by the central processor.

5. The building controller also receives alarms concerning off standard environmental conditions or emergencies such as fire and relays the alarms to the central processor for further action. This system should operate electronically using 1-5 volts or 4-20 milliamp signals although the final control device may be powered by a pneumatic system with clean, dry air with a 20 psi system pressure. Final control devices will consist of valves and damper positioners. No control functions (PID) are to be done with pneumatics. If devices are used that require air then provisions must be made in the design that details a separate air compressor, air dryer and receiver including all other associated appurtenances required for compressed air supply to these devices.
  
6. The building control system shall be capable of operating the building utility systems independently, but must also be constructed to accept signals from the campus EMS without extensive interconnecting equipment. The building control device must also be able to communicate data concerning building status to the central processor upon demand. The design must detail method of tie-into existing EMS system (i.e. telephone line, fiber optic, etc.) and must detail how the connection is to be made. The design must also detail what programming has to be done to the main EMS system in order to accept new signals. The cost to hook-up and reprogram the EMS system must be included in the cost of the project.

### **15910: Direct Digital Controls**

#### Test Plan

1. Prepare a written test plan indicating in a step-by-step, logical fashion, the procedures by which the automatic control system will be tested, adjusted, and checked.
  
2. Not less than 6 weeks prior to testing, provide copies of the proposed test plan for approval in accordance with the specifications for submittals. Meet and discuss the test plan, and make agreed changes to the written plan. Resubmit the revised test plan in accordance with the specifications for submittals.
  
3. The Test Plan shall include, as a minimum, for each system and subsystem of the automatic control work, the following:
  - a. System name.
  
  - b. List of devices with brief description of functional purpose of each.
  
  - c. A description of the expected signal values transmitted by the sensor.
  
  - d. A description of the expected signal values transmitted by the controller to the control device or actuator.



- e. A description of the expected values of the control medium from limit-to-limit.
- f. A description of the instrumentation required to test the system.
- g. A detailed description of the test.
- h. A description of the expected field adjustments for transmitter, controller, and control actuator should control parameters fall outside of expected values.
- i. A log sheet or sheets on which expected and field read values will be recorded and final field read values indicating that the system is operating in accordance with contract requirements.

### Testing and Adjusting During and After Installation

1. The testing and adjusting includes the submission of a test plan which shall describe in detail the method by which each component, subsystem, and system will be tested, calibrated, adjusted, and retested after installation in accordance with the specified sequences of operation and other characteristics of the control system.
2. A report on test results, including set points and operating ranges of all components shall be submitted in accordance with submittal specifications. The set points and operating ranges of all components shall be recorded to be submitted as part of the commissioning tests results.
3. The testing specified in this paragraph shall not replace the testing specified in “Commissioning Tests.”
4. The entire test shall be witnessed by the University and the A/E.
5. Upon satisfactory test, a copy of the final test results shall be bound in the Operating and Maintenance Manual.

### Commissioning Tests

1. In addition to the “Testing and Adjusting During and After Installation”, the contractor shall perform commissioning tests to verify that the entire automatic control systems are designed, installed, and adjusted to perform as required in the contract. This phase is an extension, not a substitute, of the phase “Testing and Adjusting During and After Installation.”
2. Demonstrate all calibration and tests performed under “Testing and Adjusting During and After Installation.”
3. Verify each and every control sequence.

#### 4. Verification of Electronic Digital Controllers

- a. Verify the operation of the microcomputer operating system of the field panels. Demonstrate proper automatic restart of equipment after power restoration.
- b. Verify each and every required application software. They shall include, but not be limited to:
  - 1) All control sequences specified for each local loop
  - 2) Time of day scheduling
  - 3) Chilled water reset
  - 4) Outdoor air reset
  - 5) Zero energy band program
  - 6) Unoccupied cycle
  - 7) Temperature compensated duty cycling
  - 8) Start/stop time optimization
  - 9) Event initiated programs
  - 10) Trending
  - 11) Peak demand limiting
- c. Verify the operation of the operator's keypad, including levels of security to access the keypad.
- d. Verify self-diagnostics of the field panel. Demonstrate activation of diagnostics from local operator's keypads. Each field panel shall be verified.
- e. Verify the operation of the clock routine in the field panel.
- f. Verify the operation of the intrusion alarm of the field panel.
- g. Demonstrate changing of default values of sensors through local keypads.
- h. Demonstrate proper system operation while setpoints and data are being modified.
- i. Verify operation of all terminal unit controllers.

#### 5. Mechanical system demonstration

- a. Demonstration shall include the operation of the entire mechanical system under the control of the contractor and shall include the start-up, operation, and shutdown of the system in accordance with the sequence of operation.
  - b. The operation of each device shall be performed in accordance with the written instructions contained in the operation and maintenance manual, a copy of which shall be available 10 working days prior to the test. No deviation from the procedures in the operating manual will be permitted.
  - c. Should the system fail to perform in accordance with the requirements of the operation and maintenance manual, the system shall be repaired, recalibrated, retested as necessary, and a second demonstration performed at no additional expense. The contractor shall reimburse the expenses of the commissioning team for each test after the first.
6. All commissioning tests, verifications, and demonstrations shall be witnessed by the University.
  7. For any test, verification, or demonstration that fails to meet the specification requirements, the component of the automatic control system causing the control system failure, be it hardware, firmware, or software, shall be repaired, replaced, or readjusted. The failed test, verification, or demonstration shall be repeated.
  8. Upon satisfactory tests of the automatic control systems, copies of the final test results shall be bound in the Operating and Maintenance Manual.

### *Final Operational Test and Acceptance*

1. The final operational test and acceptance shall constitute an operational test over a 30 day period that the system performs the functions and intent of the contract requirements. During this period of time, the contractor shall be required to maintain an on-site presence of service technicians. During the 30 day test period, the University's trained personnel shall operate the system in accordance with the manufacturer's requirements and shall log all deviations, failures, and other deficiencies which constitute contract nonperformance. The requirement for minor adjustments and/or system modifications, shall be submitted in writing stating the scope of said modifications and the need therefore, prior to implementing such changes.
2. During the 30 day test duration, the system shall demonstrate its continuous functional and operational capabilities without breakdown or shutdown defined as "UPTIME." During the testing period, the UPTIME of all field panels, terminal microprocessors, host computer and peripherals, network, etc. shall not be less than 95%. The tests shall be extended on a day-by-day basis until the UPTIME over 30 consecutive days meets the stated level, at which time the system will be accepted by the University.

### Guarantee and Service

1. Instrumentation and control equipment shall be guaranteed in writing against defects in workmanship and defective materials for a period of one year after acceptance by the University. During this time, instrumentation and control equipment shall be kept in proper operating condition at no additional cost to the University.
2. Provide one year free service on all instrumentation and control equipment and components during the guarantee period.
3. Emergency service: The University will initiate service calls when the control system is not functioning properly. Qualified personnel shall be available to provide service to the completed control system. Furnish the University with a telephone number where the service supervisor can be reached at all times. Service personnel shall be at the site within the next business day after receiving a request for service and shall restore the control system to prior operating condition within 3 days.
4. The contractor shall diagnose/troubleshoot via modem at no additional cost during the warranty period.
5. Response time for notification of problem shall be as follows: 4 hour remote modem diagnostics, 12 hour on-site assistance.

### **15950: Testing, Adjusting, and Balancing**

1. In accordance with the submittal specifications and 01810, submit a synopsis of the testing, adjusting, and balancing procedures and proposed agenda.
2. In accordance with the submittal specifications, submit sample forms, if other than those standard forms prepared by the AABC or NEBB are proposed.
3. Draft Reports: In accordance with the submittal specifications, prepare and submit draft reports on the approved forms upon completion of testing, adjusting, and balancing procedures. Draft reports may be hand written, but must be complete, factual, accurate, and legible. Organize and format draft reports in the same manner specified for the final reports.
4. Final Report: In accordance with the submittal specifications, prepare and submit a final report. Bind approved report forms complete with schematic systems diagrams and other data in reinforced, vinyl, three-ring binders. Provide binding edge labels with the project identification and a title descriptive of the contents.
5. Report Contents:
  - a. General Information and Summary: Inside cover sheet to identify the testing, adjusting, and balancing agency, Contractor, Owner, Architect, Engineer, and Project. Include addresses, and contact names and telephone numbers. Also

include a certification sheet containing the seal, name, address, telephone number, and signature of the Certified Test and Balance Engineer. Include a listing of the instrumentation used for the procedures along with the proof of calibration within six months prior to starting the project.

- b. The remainder of the report shall contain the appropriate approved forms for each respective item and system. Prepare a schematic diagram for each item of equipment and system to accompany each respective report form.
6. Agency Qualifications: The independent testing, adjusting, and balancing agency shall be certified by the National Environmental Balancing Bureau (NEBB) or the Associated Air Balance Council (AABC) in the testing and balancing disciplines required for the project, and have at least one Professional Engineer registered in the State of Virginia, certified by NEBB or AABC as a Test and Balance Engineer.
  7. Pre-balancing Conference: Prior to beginning the testing, adjusting, and balancing procedures, schedule and conduct a conference with the University, Engineer, and representatives of installers of the mechanical systems. The objective of the conference is final coordination and verification of system operation and readiness for testing, adjusting, and balancing.
  8. Mark equipment settings, including damper control positions, valve indicators, fan speed control levers, and similar controls and devices, to show final settings. Mark with paint or other suitable, permanent identification materials.

**End of Section**

## ***Division 16: Electrical***

### **16000: General Requirements**

1. In all cases, GMU shall be consulted regarding source of power. The primary or main distribution service voltage utilized at various GMU installations are as follows:
  - a. Arlington Campus:
  - b. Fairfax Campus:
  - c. Prince William Campus:
  - d. Other Remote Locations: GMU and the utility company shall be consulted regarding power source, location and characteristics.
2. Provide new electric meters for all new buildings.
3. Electrical closets and distribution shall be centrally located throughout the building.
4. In atriums or other multi-story open to roof areas, accessibility and maintenance should be a consideration when mounting lights.
5. Access doors to crawl spaces should be located as close as possible to electrical equipment under floor.
6. Provide separate electrical and telecommunications closets. Custodial closets shall not be used to house electrical or telecommunications equipment.
7. Provide one duplex receptacle for each stair landing.
8. Corridor wall receptacles (primarily used for floor cleaning equipment) shall be circuited separate from interior office/classroom receptacles.
9. Electrical wiring system shall be designed and installed with as much flexibility as practical and reasonable.
10. In demolition associated with renovations, all wire shall be removed back to the panel board and all accessible conduits shall be removed.
11. For back-up power, emergency generators are preferred to battery systems.
12. Emergency Light and Power (see also 16530):
  - a. During the design development phase of any facility, the extent of emergency lighting and power required shall be determined in order to establish the alternate power source. The total requirement shall dictate the use of engine generator, local battery or central battery stand-by sources. Location of the generator exhaust outlet must not be located where it would affect building occupants.

- b. Buildings requiring only emergency lighting should be handled through local battery or central battery system based on total load and economic of system.
  - c. Buildings requiring operation of motor driven equipment, and/or elevator as well as emergency lighting shall use engine generator unit as the standby source.
  - d. For emergency generator, see 16230.
  - e. Emergency system wiring shall be in separate conduits, and its distribution through separate panelboards and motor control centers, etc. as required for a complete system to serve exit lights, safety lighting in corridors and stairwells, in general assembly areas, and Mechanical Equipment Rooms and electrical rooms for essential loads, for security systems, fire alarm, and as required.
13. Electrical provisions for elevators: see 14200.
14. For cathodic protection, see 13110.

## **16050: Basic Electrical Materials and Methods**

### **16060: Grounding and Bonding**

1. Drawings shall show ground systems, protective conduit sizes, and relative locations. Specifications and drawings shall include detailed requirements of the grounding system. A reference only to the National Electrical Code and/or specifying requirements only be referencing the code are not acceptable.
2. Service grounding electrode shall be on the street side of cold water valve and also provide a made grounding system. A reference only to the National Electrical Code and/or specifying requirements only be referencing the code are not acceptable.
3. Ground connections that are permanently concealed shall be made by the exothermic process to form solid metal joints. Accessible ground connections shall be made with mechanical pressure type connectors.
4. Provide an equipment grounding conductor in each of the following conduits and connect to the grounding system at each end:
  - a. In each run of non-metallic conduit.
  - b. In each feeder from main panelboard to each panelboard.

- c. In each run of metallic conduit that includes a section of flexible or liquid-tight conduit.
5. Grounding conductor in metallic conduits shall be 600 volt green insulated copper conductor sized per NEC code. Where a shock hazard to personnel may exist by the frequent and continued contact with machines or equipment (fixed or portable), a wire equipment ground shall be installed in the branch circuit conduits and be grounded to the cabinet of the panelboard by an uninsulated ground bus. The neutral bar of the panel shall not be used for equipment grounds.
6. The complete electrical installation shall be permanently and effectively grounded per code. This includes switchboards, panelboards, cabinets, transformer neutral, transformer ground pad, motor frames, motor starters, lighting fixtures, lightning arresters, conduit systems, and all non-current carrying metal parts of electrical equipment. Steel frame buildings shall be grounded through a low resistance ground system.
7. Convenience outlets shall have a wired ground for continuity of ground path from the device grounding pole.
8. Provide a driven ground rod at outdoor lighting poles for equipment grounding, and provide an equipment ground wire in PVC underground conduits to the poles.
9. A system ground shall be provided for each separately derived system including service entrance, each voltage level, and generators.
10. An isolated ground shall be provided where required for designated sensitive electronic equipment in any facility. An isolated ground bus must be provided in the source panel and connected back to the service ground point by an insulated ground conductor.

## **16100: Wiring Methods**

### **16120: Conductors and Cables**

1. Use of MC cable is not permitted.
2. All conductors shall be copper. All power conductors shall be awg #12 or larger. Minimum control wire shall be awg #14 and minimum signal wire size no smaller than awg #18.
3. Secondary Distribution
  - a. Wire for low voltage (600 volts and below) circuits shall be single conductor stranded copper of not less than 98% conductivity with 600 volt, Type



THHN/THWN insulation. Type XHHW may be used for sizes #2AWG and larger.

- b. Wire and cable No. 12 AWG and smaller, shall be made with approved insulated indentation or spring insert type pressure connectors. Connections and splices in low voltage wire, No. 8 AWG and larger, shall be made with approved insulated spring insert type pressure connectors or bolted or compression-crimped type pressure connectors covered with an insulating filler tape, "Scotch-fil", or approved equal, and two half-lap servings of vinyl electrical tape, Scotch #33 or approved equal. All taped connections exposed to weather or moisture shall be given two coats of weatherproof insulating paint, Okonite, or approved equal.
- c. All conductors shall be color-coded throughout and numbered and tagged to each junction box, pull box, panel and device with suitable fireproof tags or adhesive identification bands. Color-coding of conductors for power and branch circuits shall be as follows:

| For 120/208 Volt System | For 277/480 volt System |
|-------------------------|-------------------------|
| Phase "A": Black        | Phase "A": Brown        |
| Phase "B": Red          | Phase "B": Yellow       |
| Phase "C": Blue         | Phase "C": Orange       |
| Neutral: White          | Neutral: White          |
| Ground: Green           | Ground: Green           |

- d. Branch Circuit Feeders: The design shall be for acceptable voltage drop and capacity for 20% load growth above initial design.
  - e. Branch Circuits: These circuits shall not be loaded to more than 80% of panel breaker ratings. Not more than six unassigned general use duplex convenience outlets shall be on any one 20 ampere branch circuit.
  - f. Feeder sizes and protections shall not be such a large percentage of the main that coordination of devices cannot be achieved.
  - g. Use two wire circuits with individual neutral conductors for all branch receptacle circuits in administrative, office, computer laboratory and classrooms, and general laboratory areas.
4. Primary Distribution:
- a. All high voltage cable shall conform in material, construction and tests to all applicable requirements of the Insulated Cable Engineers' Association.

- b. All cable for primary service and distribution circuits shall be single conductor, copper conductor, copper tape shielded type with a solid dielectric, vulcanized, rubber-like, elastomeric, thermosetting insulation, ozone-moisture-corona resistant, rated 90° C., and PVC sheath, as manufactured by the Kerite Co. or with an extruded semi-conducting strand screen, okoguard insulation extruded semi-conducting insulation screen, copper tape shield and okolon jacket as manufactured by the Okonite Co., or equivalent as manufactured by Pirelli. Cable shall be rated 5KV, or 15 KV depending on distribution system at campus location, and shall have 133% insulation level. Cable shall be UL listed as Type MV-90.
- c. All cable in manholes shall be wrapped in two "opposing layers" of fireproofing tape secured in place with glass-cloth binder type. Slack cable shall be provided in manholes by routing the cables by the longest path possible through the manholes.
- d. All cables in manholes shall be properly supported on cable supports a minimum of every 36". Provide new cable supports in existing manholes as required for proper support of both the new and existing cables.
- e. High voltage cables shall be terminated in accordance with the cable manufacturer's recommendations using terminators specifically recommended by the type of cable specified.
- f. Terminations and splices shall be performed by a certified experienced cable splicer. Taped "T" splices are not permitted; they shall be made using elastimold, or approved equal, disconnectable fittings.
- g. Primary cables shall be color coded at all terminations and in manholes with colored tape:
 

|          |       |
|----------|-------|
| Phase A: | Black |
| Phase B: | Red   |
| Phase C: | Blue  |
- h. Cables shall be identified in manholes as to source and destination.
- i. Tests: High voltage DC proof tests shall be specified on all primary cable installations in accordance with the cable manufacturer's recommendation and written report shall be supplied to GMU.

### **16130: Raceway and Boxes**

- 1. Minimum conduit size shall be ¾". Flexible metal conduit shall be used only for whips to lighting fixtures and equipment. All empty conduits shall have a 65-lb. test polymer (or equivalent) pull string tied off at both ends.

2. Galvanized rigid steel conduit shall be hot-dipped galvanized steel inside and outside comply with UL Standard 6, Federal Specification WW-C-581-D and ANSI C 80.1. Galvanized rigid steel conduit shall be used for the following:
  - a. Buried raceways in concrete slabs (except for main services which shall be PVC conduit concrete encased ductbank) or in the ground. Where directly buried, two coats of asphaltic compound shall be applied.
  - b. Interior high voltage runs.
  - c. Exposed exterior raceways.
  - d. Any raceway in hazardous areas.
  - e. Termination of ductbank runs through concrete and into equipment or indoor areas.
3. Electro-Galvanized Steel Metallic Tubing (EMT) shall comply with UL Standard 797, Federal Specification WW-C-563 and ANSI C 80.3. EMT shall be used for the following:
  - a. Interior branch circuits exposed, concealed in hung ceilings and wall partitions, in masonry or concrete.
  - b. Interior feeders exposed or concealed.
  - c. Interior motor circuit wiring.
  - d. Interior control, signal and sound wiring exposed, concealed in hung ceilings and wall partitions.
4. Rigid Plastic Conduit, Schedule 40 PVC, shall be used for the following:
  - a. Underground primary or secondary service ductbank encased in red concrete, rigid galvanized steel elbows shall be used where the conduit is run through concrete slab. Also a separate grounding conductor with green insulation shall be provided in these runs.
  - b. Underground telephone service ductbank encased in concrete.
  - c. Lightning protection down leads, and individual ground conductors.

5. Underground ductbank runs shall be installed minimum of 30" below grade to top of bank, wherever possible. If 30" is not possible, concrete encased ducts may be installed to minimum burial depth stipulated in NEC. Underground runs cable markers shall be installed for all direct-buried cables and cables in non-metallic and metallic raceways. Marker shall be located directly over buried lines at 8 to 10 inches below finished grade. Marker tape shall be standard metallic lined, permanent, bright red colored continuous printed plastic tape for direct burial service, not less than 6 inches wide by 4 mils thick, and printed, "caution electric line buried below." See also 02580.
6. Liquid-Tight Flexible galvanized steel conduit with continuous copper bonding conductor shall be used for connection, not exceeding 18" in length, to all motors, heating and ventilating controls, and at other locations where vibration, movement, moisture, or oil-vapor atmosphere are encountered.
7. Hot-Dipped galvanized, single strip flexible steel conduit, not exceeding 6' in length shall be used for connections to be recessed and chain hung lighting fixtures.
8. Plastic jacketed rigid steel galvanized conduit shall be used in corrosive atmospheres.
9. Rigid aluminum conduit may be used in lieu of rigid steel conduit, except where in contact with or in earth, concrete or masonry.
10. Conduit shall be 3/4" size minimum. Flexible steel conduit of 1/2" diameter may be used for connections to be recessed and chain hung lighting fixtures.
11. Where empty conduits are required to be installed, provide a continuous #12 nylon draw line with identification tag securely attached to both ends.
12. Suitable expansion and deflection fittings with grounding continuity shall be provided in each conduit run at each point where the conduit run crosses a building expansion joint.
13. All wiring shall be installed concealed in ceilings, walls, slabs, pipe chases and furred spaces whenever possible. Conduit may be installed exposed only in Mechanical Room, Electrical Room and Janitors Closets. Concealed conduit shall be installed in a direct line, with bends as long as practicable. Exposed conduit shall be installed parallel to or at right angles with the lines of the Building, as closely as possible to walls, ceilings, columns and other structural parts, consistent with proper space for access to boxes and so as to occupy a minimum of space. Where exposed conduits are grouped, they shall be run parallel and equally spaced.
14. Surface metal raceways with snap-on covers shall be used for exposed runs in finished areas, for counter and workbench power and data outlets where required. Acceptable manufacturers are Wiremold, mono-systems and Isoduct.
15. For underground service see section 02580.

## **16140: Wiring Devices**

1. All wiring devices shall be industrial heavy duty specification grade, rated a minimum 20A, 125V.
2. Local wall switches shall be heavy duty specification grade, toggle, quiet type, ivory, fully enclosed in composition cases, rated 20 amp. 120/277 volt AC; Hubbell #1221 Series, or approved equal.
3. Receptacles generally shall be duplex, specification grade, 2 pole, 3 wire grounding type conforming to latest NEMA standards for 20 amp, 125 volt with back and side wiring, ivory; Hubbell #5362, or approved equal.
4. Receptacles for use with specific equipment, special applications, etc. shall be suitable for the load to be served and of proper configuration for the mating plug.
5. Switches and receptacles for wet hazardous areas shall be an approved type for the environment served.
6. Receptacles fed from emergency power upon failure of normal power shall have cover of steel with red baked enamel and word "EMERGENCY" marked in white letters on cover.
7. Ground fault interrupter type receptacles shall be duplex 120V. AC 15 or 20 amps as required, Class A.
8. Device plates, telephone outlet plates, and blank plates in finished areas shall be .04 gauge 302 stainless steel with brushed finish.
9. Surface mounted multi-outlet system:
  - a. Multi-outlet systems shall consist of surface mounted metal raceways for use with number and type of wiring devices as required. Systems shall be complete with all fittings, etc. and shall be equal to Wiremold 2000 and G-3000.
  - b. Systems requiring combination power and telephone/communication multi-outlet with divider shall be equal to Wiremold G-4000 and G-6000 as required.
10. Provide 20 amp duplex outlets at each floor landing of each stair. Provide at least one 20 amp duplex outlet in corridors and space such outlets at 75 feet on center in all corridors.

## **16200: Electrical Power**

## **16220: Motors and Generators**

Motor voltages: Motors 1/2 HP and larger shall be 3 phase 60 Hz, 208 volt or 460 volt based on system secondary distribution. Motors under 1/2 HP shall be single phase 60 Hz, 115 volt or 208 volt.

## **16230: Generator Assemblies**

### Emergency Generators

1. Emergency generators rated 50KW or less shall be natural gas fuel (where available at the site) with propane backup. Fuel tanks shall not be located underground. Propane tanks shall be furnished by the Owner. Emergency generators rated above 50KW shall be diesel. Provide a minimum 8-hour operation fuel tank built into the base of the unit wherever possible.
2. Provide load bank for generators to use when cycling for maintenance. At a minimum, provide a connection for a portable load bank.
3. Consider emergency generator exhaust path in relation to make-up air and building openings.
4. Size generators big enough for load shedding, which may require the generator to serve more than one facility.

## **16300: Transmission and Distribution**

### **16360: Unit Substations**

1. Buildings and their equipment shall be served by unit substations where applicable as required for the load. Generally substations shall be single ended type, and the secondary or building distribution system voltage shall be as follows:
  - a. 480Y/277 volt 3 phase 4 wire 60 HZ for buildings with large power loads utilizing 277 volt for most lighting, and small 480 to 120/208 volt transformer for receptacles, lighting and small equipment loads as required.
  - b. 208Y/120 volt 3 phase 4 wire 60 HZ for buildings with small power loads that can be readily served by this voltage.
  - c. Buildings requiring almost equal quantities of both a. and b. above should be served by two unit substations, one for each low voltage service.

## 2. Type and Location of Building Substations:

- a. Outdoor compartmental type pad mounted, completely enclosed, liquid filled power transformer with load break primary disconnect, or two "on-off" load break disconnects for loop feed service where required by campus distribution, primary fuses and lightning arresters may be used to serve the building. This shall be located close to building electrical equipment room to keep secondary runs from outdoor transformer to indoor main distribution switchboard as short as possible. Main power distribution switchboard shall be located in building electrical room, NEMA 1 construction. The secondary power distribution switchboard shall be similar to that below for indoor units.
- b. Indoor unit substation shall consist of a load break primary disconnect, or two "on-off" load break disconnects for loop feed service where required by campus distribution system, primary fuses, primary lightning arresters; dry type ventilated power transformer; and main secondary power distribution switchboard. Unit substations shall be provided as a completely enclosed, integrated and coordinated line-up by the manufacturer. The two primary "on-off" load interrupter switches for loop feed shall be in individual vertical section connected together on the load side and key interlocked to prevent both incoming circuits from being connected to transformer at the same time. Primary sections shall be equipped with copper ground bus. Incoming primary service shall be underground wherever possible. Primary fuses shall be disconnect type S & C type SM5, or approved equal. Dry-type ventilated transformer to have maximum temperature rise of  $115^{\circ}\text{C}$ . above a  $40^{\circ}\text{C}$ . maximum ambient, to be equipped with provisions for forced cooling, to have 4 - 2-1/2 full capacity taps in high voltage winding 2 above and 2 below normal, and ground pad. Main secondary switchboard shall be front accessible, with vertical sections as required bolted together to form one metal enclosed rigid switchboard constructed to NEMA PB-2 and UL 891 standards. It shall be equipped with Owner's metering section with an ammeter and selector switch, voltmeter and selector switch and KWHR meter demand attachment. Unit shall have a main circuit breaker, and feeder branch circuit breakers as required to serve loads plus two spare feeder breakers. Rating of main bus, circuit breakers, etc. shall be determined based on building transformer rating and building distribution system to serve loads. Interrupting capacity shall be determined and noted on system one line diagram main buses and equipment. Provide a ground copper bus in switchboard for its entire length firmly secured to each vertical section. Provide space for future breakers. Incoming secondary service shall be underground wherever possible. Breaker loading shall be a maximum of 80% of its rating unless breakers are specified and available as fully rated units for switchboard service. Each breaker on the switchboard assembly shall have an engraved lamacoid nameplate to designate load served.
- c. Selection of a. or b. above will depend on site location of new facility, indoor space availability for mechanical and electrical equipment, etc. and shall be determined by discussions with the University.

## 3. Secondary Distribution Systems: Due to the increasing use of solid state devices for personal computers, data processing units, electronic ballasts, and variable speed

drives in a facility, the building electrical system in a facility must be designed to accommodate these non-linear loads. Where these loads are prevalent, the design must include transformers designed for non-linear load application, and over sizing of distribution panel neutrals as well as the neutral conductors of the system feeding these panels.

### **16400: Low-Voltage Distribution**

1. One line diagram of electrical system shall be posted in the switchgear room or in vicinity of main distribution panel.
2. Panelboards shall be flush mounted only in areas with grid type ceilings or open ceilings. Do not locate panelboards in custodial closets.
3. Distribution panelboard shall be provided complete with all mounting hardware for mounting any size breaker that the panel will accept and breakers shall be plug-in type.
4. Provide a minimum of one 100 ampere, 30 pole panelboard per laboratory.
5. Provide 50% spare breaker space in each distribution panel in all new buildings. Provide 20% spare breaker space in each panelboard.
6. All panelboard indices shall identify all equipment served by each circuit, (i.e. Rcpt - Rooms 111, 112, 115).
7. Any panelboard spaces shall be fully bussed.
8. Include power circuit for card key door locking hardware.
9. Provide power circuit(s) for automatic door openers.

### **16410: Enclosed Switches and Circuit Breakers:**

1. Circuit breakers shall be of the molded case, bolted in type consisting of the number of poles and ampere ratings as required. Two and three pole breakers shall be of the common trip type. Handle extensions providing manual operation will not be accepted.
  
2. Circuit breakers shall be of the indicating type providing "on", "off" and "tripped" position of the operating handle. When the breaker is tripped the handle shall assume a position between "on" and "off" positions. Breakers shall be of the quick-make and



- quick-break type toggle mechanism with inverse time trip characteristics. Automatic release shall be secured by a bimetallic thermal element releasing the mechanism latch. In addition, a magnetic armature shall be provided to trip the breaker instantaneously for short circuit currents above the overload range.
3. Circuit breakers shall be rated for the voltage of the circuit on which they are used. Circuit breakers with 225 ampere or larger frame sizes shall have interchangeable trips.
  4. Locking tabs shall be provided on all circuit breakers serving emergency lighting, fire alarm system, security systems and other emergency or critical equipment.
  5. Interrupting capacity of breakers shall be suitable for the power system. Available short circuit currents shall be noted on single line diagram on all major system buses and on panel schedules.
  6. Circuit breakers feeding 120 volt lighting circuits that are not controlled by local wall switches shall be approved type "SWD" circuit breakers.

#### **16440: Switchboards, Panelboards, and Control Centers**

1. All panelboards shall be rated for the intended voltage and shall be in accordance with Underwriter's Laboratories, Inc., standards for panelboards and standards for cabinets. Panelboard boxes shall be so labeled.
2. Panelboards shall be initially designed to that they are not loaded more than 75%. Provide spare breakers and spare space.
3. Panels shall consist of factory completed dead-front assemblies of sheet steel cabinets, main buses, over-current and switching units and sheet steel trim.
4. Boxes shall be 20 inches wide and fabricated from unpainted, galvanized code gauge sheet steel having multiple knockouts with lapped and screwed or welded corner construction. Boxes shall be of sufficient size to provide a minimum gutter space in accordance with NEC Tables 373-6(a) and (b), but not less than four inches at the side and six inches at top and bottom. Multi-section panelboards shall be provided with a minimum top and bottom gutter space of 8 inches. Where feeder cables supplying a panel are carried through its box to supply other panels the box shall be provided with a separate barriered side gutter. Cables shall be bundled, routed and supported within the gutters. This wiring space shall be in addition to the minimum gutter space specified above. A minimum of four interior mounting studs shall be provided.
5. Trims shall be fabricated from code gauge galvanized sheet steel. Trims shall be fastened to cabinets by means of machine screws with captive nuts or clamps and shall be self-supporting on the cabinet after trim holding screws have been removed. Trim for flush panels shall overlap its perspective box by at least 3/4 inch all around. Surface trim shall have the same width and height as its respective box. Doors and trims shall each be in one piece so designed that door will close without a rabbet.

6. Panel doors shall be fabricated from the same material as the panel trim and shall be fastened thereto by continuous concealed hinges. Doors shall be so installed that no live parts are exposed when the door is opened. Doors shall be complete with flush type combination lock and catch with keys. Doors over 48 inches high shall be provided with vault handle, built-in locks and three point catch fastening door at top, bottom and centers. All panels shall be keyed alike. Doors shall be provided for access to contactors, time clocks, relays, and similar devices as required.
7. Backbox interiors, inside trim, door and exterior shall be treated with a rust inhibiting phosphatized coating after pickling and finished in ANSI-61 gray enamel. A typewritten directory, eight inches by ten inches, with metal frame and clear plastic face shall be furnished and installed upon the inside of the door of each panelboard, indicating the room or area and the service controlled by each circuit.
8. Bus bars shall be hard drawn copper and extend the full height of the panel without reduction. Buses shall be arranged for sequence phasing of branch circuits. Circuit loading shall be distributed evenly over all phases. The neutral bus shall have a suitable lug for each outgoing branch circuit requiring a neutral connection. Neutral bus shall be full size and electrically isolated from the cabinet. Ground bar shall be bare uninsulated and suitable bolted to the cabinet for equipment grounding. Busing shall be braced throughout to conform to industry standard practice governing short circuit stresses in panelboards. Bracing shall be equivalent to, or compatible with, the rated interrupting capacity of the smallest overcurrent device in that panelboard. Spaces for future devices shall be bussed for the maximum device that can be fitted into them with suitable insulation and bracing to maintain proper short circuit rating. All provisions shall be made for ready insertion of future protective devices. Provide an isolated ground bus where required by special sensitive equipment.
9. All interiors shall be completely factory assembled with switching and protective devices, connectors, etc. They shall be so designed that switching and protective devices can be replaced without disturbing adjacent units and without removing the main bus connectors and shall be so designed that circuits may be changed without machining, drilling or tapping. Branch circuits shall be arranged using double row construction.
10. Multiple section panels shall have feed-thru lugs with full capacity taps to adjacent panel sections.
11. Lighting and power panels for 480Y/277 volt system and receptacle, appliance and power panels for 208Y/120 volt system shall be of the bolted circuit breaker type with single, two and three pole branches of quantity and trip setting as required. Panelboards shall be furnished with main overcurrent interrupting devices consisting of circuit breakers of size and capacity as required.
12. Multiple cable lugs for incoming feeder cables shall be furnished where required. Lugs shall be secured to bus by stud bolts. Where several panels are fed by one feeder, solid tap connections shall be made in separate side gutters as required with

- tap connectors. Suitable lugs or connectors shall be provided for connecting feeders. Tap connections to multiple lug feeders shall be made to all lugs at each tap joint.
13. When lighting circuits are switched in groups, these circuits shall be controlled by contactors mounted under a separate door in the lighting panel.
  14. Motor Control: A motor control center shall be provided to handle 3 phase motors in a given area. Single phase motors can be fed from lighting and/or power panels. Motor control circuits shall be 120 volt 60 Hz.
  15. Motor starters (Individual), Magnetic Type:
    - a. Starter units for three phase motors shall be the combination full voltage type, consisting of a magnetic starter containing three manual reset thermal bimetallic overloads and low voltage protection. Each starter unit shall include a circuit breaker (MCP) disconnect for short circuit protection and provisions for locking switch, handle in the "on" and "off" positions. Each starter unit shall be complete with 2 extra normally open interlock contacts. Starters shall be mounted in NEMA 1 enclosure indoors and NEMA 4 outdoors. Minimum size shall be NEMA 1.
    - b. Units shall be equipped with individual 120 volt secondary control transformers as required with two primary and one secondary control fuse. The other secondary lead shall be grounded. Where indicating lights, solenoid valves and additional control components are energized from the control transformer, the capacity of the control transformer shall be proportionally increased.
    - c. Starter shall have "Hand-Off-Auto" selector switches and indicating red "run" light mounted on the starter. Control units shall be of the heavy duty oil tight type. Lights shall be 120/6 volt type with lamp voltage rated 150% of normal voltage and of the miniature bayonet type only.
  16. Manual motor starters for single phase motors shall be 2 pole, have a quick-break quick-make toggle mechanism that can be locked in "off" position, with a neon pilot light to indicate when motor is running, with thermal overload units as required. Enclosure shall be NEMA 1 for indoors, NEMA 4 for outdoors, or NEMA 7-9 for hazardous areas.
    - a. Motor control centers shall be NEMA Class 1, Type B wiring. The 480V motor control centers shall consist of independent vertical sections, free standing on 4" channel iron sills with sections bolted together to make up the center. The section shall be 90" overall height, including the mounting sills. The width of each section shall be 20" (except large starters or other special panels which may be 30" in width). Structure depth shall be 20" and designed to mount starters in the front only. A maximum of six starter units shall be stacked in one vertical section. Terminal blocks for wiring shall be mounted within each starter unit and shall be factory wired. Each section shall be dead front, and rear access shall not be necessary for connections. Removable rear plates shall, however, be employed on the rear of the structure. Pan type doors shall be used for all units and future

spaces. Doors shall be hinged to the structure with a concealed hinge and fastened with pressure type fasteners. The top of each section shall have removable plates for access to the horizontal feeder bus and for conduit entry. A minimum of 12 gauge steel shall be used throughout the structure, including all doors and plates. All painted steelwork shall be treated with a primer coat and a finish coat.

- b. The top of each section shall contain horizontal feeder bus bars of tin plated aluminum or copper which shall run continuously through the center from section to section. Provisions shall be made for easy addition and connection to adjacent sections. The horizontal bus shall be sized as required by the load, but in no case less than 600 amperes. The horizontal bus shall be braced to withstand the maximum fault current available at that point. The bus supports shall be formed of high dielectric strength, low moisture absorbing, high impact material with ample creepage distance between bus bars. Each section shall contain 3 vertical bus bars running the full working height of the section and connected to the horizontal feeder bus bars. The vertical bus bars shall be braced to withstand the maximum fault current available at that point. The bus support shall be formed of high dielectric strength, low moisture absorbing, high impact material with ample creepage distance between bus bars. Vertical bus shall be sized as required by the load, but in no case less than 300 amps.
- c. Each section shall have a top horizontal wiring trough in front of the main horizontal bus. This wiring trough shall be protected from the horizontal bus bars by means of a steel barrier plate. The wiring trough shall be equipped with cable supports and the structure shall have a cutout in the end for continuous cable runs through the motor control center. A vertical wiring trough shall run the full working height of each section and shall be equipped with cable tie clamps. This vertical wiring trough shall be designed so as to allow installation wiring to the units with the unit doors open, but with the units in place.
- d. Motor starter units shall be of the combination type with motor circuit protectors coordinated with motor overload relays. The interrupting rating assigned to the complete combination motor starters shall exceed the system short circuit capacity at the starter terminals. Starter units shall meet the requirements specified above.
- e. A magnetic trip only molded case circuit breaker which serve as a main disconnect shall be provided where required. A horizontal copper ground bus 1/4" x 1" shall be provided with lugs for termination of the feeder and branch circuit ground conductors. Motor starter units shall connect to the vertical bus bar in each section with stab-on connectors shall be free-flowing silver plated clips, self-aligning and backed up with steel springs. Units shall be capable of being withdrawn from the structure with a minimum of difficulty. Unit support brackets shall be provided in the structure to properly align the units. Cam latch fasteners shall be employed on each unit to latch the unit in one of two positions in the structure.
  - 1) The engaged position - Stabbed on the vertical bus.

- 2) The test position - With units withdrawn from the vertical bus, but still supported by the structure. In the test position, the pull-apart terminal block must still be capable of being engaged for electrical testing purposes.
  - f. In either engaged or test positions, the cam latching mechanism on the unit must be capable of being padlocked to prevent unauthorized movement of the unit. Units shall have complete steel top and bottom plates to provide maximum isolation between units. Units shall be of modular dimensions so that it is possible to readily interchange units of the same size without modifications in the structure.
  - g. Motor disconnect switch operating handles shall be interlocked with the door so that the door cannot be opened with the switch in the "on" position, except through a hidden release mechanism. The operating handle shall be arranged for padlocking in the "off" position with up to three padlocks. Motor starters shall be built, tested, and sized in accordance with NEMA Standards for Industrial Control, except that no smaller than NEMA Size 1 starters shall be employed in any unit. Motor overload protection shall be effected by three element overload relays with adjustable heater element positions.
  - h. Engraved nameplates shall be provided for each unit of the motor control center as well as the assembly.
17. Motor Disconnect Switch: Provide a motor disconnect switch for any motor located from its starter unit. Switch shall be horsepower rated, heavy duty type, switch blades fully visible in off position when door is open, quick-made and quick-break mechanism, handle positions shall indicate and be lockable in "on" and "off" positions. Enclosures shall be NEMA 1 indoors, and NEMA 4 outdoors.

## **16500: Lighting**

1. Light Fixtures:
  - a. Standard light fixtures are 2-,3-,or 4-lamp, 2'x4' fluorescent lay-in fixtures with electronic ballasts and T-8 lamps. T-8 lamps shall have low mercury content, a color rendering index of 75 or greater and a color temperature of 4100k in academic and general buildings. High mercury content lamps are unacceptable.
  - b. Light fixtures shall be selected to permit the use of lamps that are on State contract, readily available from multiple manufacturers and are in typical use at the University.
  - c. No lighting fixtures shall be specified for which the manufacturer will require a minimum order for the purchase of replacements. Non-catalog and custom lighting fixtures are to be economically justified and avoided whenever possible.
2. Ballasts shall be warranted for 60 months from date of manufacture and shall have harmonic distortion of less than 15%. Ballasts shall be of the parallel lamp connection design such that lamps remain fully lit if any of the companion lamps fail.

3. Owner requires the use of light emitting diode (LED) lighted exit signs with diffused lenses. Only red lettered exit signs will be used. Exit lights shall be equal to Lithnia Modular xs/xl series.
4. Typical locations for occupancy sensors include small rooms such as individual restrooms, one person offices, and small storage rooms like closets, supply rooms or recycling rooms, areas of rescue assistance and conference/classrooms when possible. Ceiling mounted occupancy sensors shall be provided in conference rooms and classrooms. Wall switches also be provided in conference rooms and classrooms such that lights may be controlled by switches when space is occupied.
5. Locate light fixture schedule on drawings. Schedule shall contain a description fixture, not simply a model number.
6. Use of fluorescent dimming systems is discouraged. When approved, the ballasts shall have a dimming range of 100% to 1%.
7. Provide dimming capability for classrooms to allow note taking while viewing a projection screen.
8. Specify standard lamps not requiring special order or premium price.
9. The following illumination levels are recommended by GMU. Illumination levels referenced are maintained levels measured at a 30" height from the floor or at an actual work surface and represent an average level for the area. See also the Construction and Professional Services Manual section 716C.

| <b>Area / Room Name</b>                 | <b>Maintained Foot Candles</b> |
|---|--------------------------------|
| Offices & Secretarial Areas             | 55 -60                         |
| Laboratories                            | 75 - 80                        |
| Study Areas & Classrooms                | 50 - 60                        |
| Conference Rooms & Meeting Rooms        | 40 - 50                        |
| Lecture Hall Auditorium / Multi Purpose | 35 - 50                        |
| Corridors & Stairwells                  | 15 - 20                        |
| Reception / Lobby, Lounge               | 30 - 35                        |
| Mechanical, Electrical Rooms            | 25                             |
| Telephone & Elevator Machine Rooms      | 25                             |

|   |          |
|---|----------|
| Receiving Areas   | 30       |
| Storage Areas   | 10 – 15  |
| Rest & Locker Rooms   | 25 – 30  |
| Critical Work areas such as tissue labs,<br>Culture plate areas, Instrument Rooms, etc. | 90 – 100 |
| Temporary site lighting for<br>Security purposes  | 1 – 3    |
| Walkways for pedestrian Safety  | 2 - 2.5  |
| Parking Lots  | 1 - 1.5  |
| Parking Decks   | 5        |

#### 10. Interior Lighting:

- a. Fluorescent fixtures are generally preferred. Use of the more efficient H.I.D. fixtures is encouraged only where practical indoors. Incandescent lighting may be used only for special effect architectural lighting or for limited dimming applications.
- b. Fluorescent fixtures of the static recessed type shall be used for most hung ceiling applications. They shall be 2' x 4', 1' x 4', or 2' x 2' based on ceiling grid, size of room or area, and architectural arrangement. Generally lenses shall be plastic injection molded prismatic type of 100% virgin acrylic. In areas requiring low brightness, numerous CRT's, or similar equipment, parabolic type louvered fixtures shall be used. Commercial fluorescent fixtures shall be used where applicable for surface or stem mounted fixture shall be metal with hinged shielding lens of 100% virgin acrylic prismatic type. Industrial type fluorescent fixtures with reflector but no lens shall be used in Mechanical Equipment Rooms, Storage and Receiving areas, and similar spaces.
- c. Fluorescent ballasts shall be electronic type with following features:
  - High frequency solid state electronic
  - High power factor (90% or higher)
  - Class P thermally protected
  - Have a harmonic distortion of less than 15% and comply with all current ANSI standards
  - Super - quiet operating sound level of 2 dB above a 16 dB ambient
  - Meet FCC requirements governing electromagnetic and radio frequency interference
  - Comply with all applicable State & Federal ballast efficiency standards
  - Listed & Approved by U. L.

- Designed for use with T8 OCTIC type (265 ma) rapid start lamps

Ballast manufacturers to be Advance, Universal or EBT.

- Fluorescent lamps shall be T8 rapid start Sylvania Octron F032/835 for 4 ft. units, and Sylvania Octron Curvalume FB031/835 (for 1 5/8" leg spacing) or FBO32/835/6 (For 6" leg spacing) for 2' x 2' fixtures, CRI 80 (minimum) 3500K color temperature or equivalent by G. E. or Philips.
- Incandescent lamps when required shall be rated 130 volt for 120 volt circuits.
- Stairwells in buildings shall have sufficient fixtures so that loss of one lamp or ballast will not leave the area dark.
- Emergency exit signs shall be Hubbell led exits, models LED-1EM RB or LED-2EM RB or approved equal with light emitting diodes as the light source.

#### 11. Exterior Lighting:

- Lighting for the entire site development of a building shall be included in the building contract documents.
- High Intensity Discharge (H.I.D) fixtures shall be used for exterior lighting of parking lots, walkways, roadways, and building perimeter security lighting. These fixtures shall be mounted on suitable standards and/or building for site lighting. Walkways, pathways, and sidewalks shall use metal halide fixtures, Kim Lighting Type EKG 401, or approved equal. Roadways and parking lots shall use high pressure sodium fixtures, Kim Lighting Type EKG 501, or approved equal.
- Street and parking lot poles shall be round, tapered, brushed aluminum. Mounting height shall be 25'-30'. Heads shall be semi-cutoff, cobra type with glass drop lens and 400 Watt High Pressure Sodium lights. Concrete bases shall be 18 inch diameter minimum, six feet below ground and set 30" above top of curb/lot surface. Concrete shall be minimum 4000 psi with steel reinforcement.
- Path and sidewalk lighting shall be non-tapered square dark brown, steel. Mounting height shall be 12'-14'. Lights shall be 150 Watt High Pressure Sodium. Concrete bases shall be 18 inch diameter minimum, four feet below ground and set 12" above walkway. Concrete shall be 4000 psi with steel reinforcement.
- Lens control shall be provided on all exterior lighting fixtures. Vandal proof fixtures shall be used if fixtures are mounted 10' or less off the ground.
- Fixtures shall be located so that dark voids and excessive glare in windows are eliminated. Accessibility for servicing and spillage onto adjacent facilities must be considered.
- For covered walkways use metal halide or mercury vapor H.I.D. downlights or wall mounted type fixtures depending on application.



- h. Include temporary security site lighting of the construction area.

## 12. Lighting Control:

- a. Timers and photo-electric control shall be used for all entrance site lighting.
- b. Occupancy sensors shall be utilized for interior lighting control for energy conservation that produce a payback in 7 years or less. The designer shall review the application of the required sensors for the various areas throughout a facility. Sensors shall not be used in areas such as corridors, stairwells, laboratories, public areas, lobbies, mechanical & electrical rooms, and any other area where a safety hazard may be created by lights going off automatically.
- c. The use of multiple switching shall be evaluated for each space and condition. Where possible, switching shall be used to effectively reduce artificial lighting near window, permit light reduction for non-critical tasks and during partial occupancy, and reduced lighting for custodial activity.
- d. All exterior and security lighting shall be powered from one location in the building, namely the main electrical room.
- e. Where dimming control is required, it shall be normally used to control incandescent lighting only. Dimmable fluorescent or H.I.D. lighting must be approved by GMU Project Manager before design of the system. Fluorescent or H.I.D. lighting shall be provided as the primary lighting source with the dimmable incandescent system as secondary.
- f. Remote switching by means of central control shall be evaluated for special areas.

### **16530: Emergency Lighting**

Emergency lighting shall be provided as required by code; including toilet areas, outdoors at all egress doors, mechanical / main electrical room and in laboratory areas.

### **16700: Communications**

1. For telecommunications service entrance requirements, see 02580.
2. For telecommunications closet space requirements, see Part II – Facilities and Spaces, Space Requirements.
3. Location and number of telephone / data outlets will vary and must be determined by consultation with building occupants. Typically one telephone / data outlet consists of a double gang outlet box with a reducer plate and a one (1) inch conduit extended to a location above the hung ceiling. Poke through outlets should be avoided. In addition to this, a separate data outlet with a double gang outlet box and a reducer plate with a blank cover plate should be provided for future use with coaxial video or fiber optic cable.

4. Labs and other heavily wired locations require proper sizing of conduits feeding computer workstation clusters.
5. No more than three (3) outlet boxes in any conduit run will be allowed. If multiple boxes are chained together, then the conduit size must be increased accordingly.
6. Cable paths to modular furniture or workstations must be enclosed and secure. Raceways between ceilings and floor or furniture must be avoided.
7. In a building with a suspended ceiling, each telephone / data outlet should be provisioned with a 1” conduit that extends from the wall outlet to 8” above the ceiling. All conduits should have a pull line.
8. Cable trays should be provisioned above ceilings for orderly horizontal distribution of telephone and data cabling.
9. The telecommunications grounding system shall be directly attached to the closest point in the building's electrical service grounding electrode system.
10. Bonding conductors shall be routed with a minimum number of bends. The bends placed in the conductor should be sweeping.
11. Make all bonding connection with listed bolts, crimp pressure connectors, clamps, or lugs. Exothermic welding may be used.
12. Multiple bus bars placed in a building shall be directly bonded with a #6 AWG copper conductor.

**End of Section**

## PART V - STANDARD DETAILS

HTHW Tunnel Detail, Fairfax Campus

[BACK to Div. 15](#)

**\*\* NOT TO SCALE \*\***

[BACK to Div. 3](#)

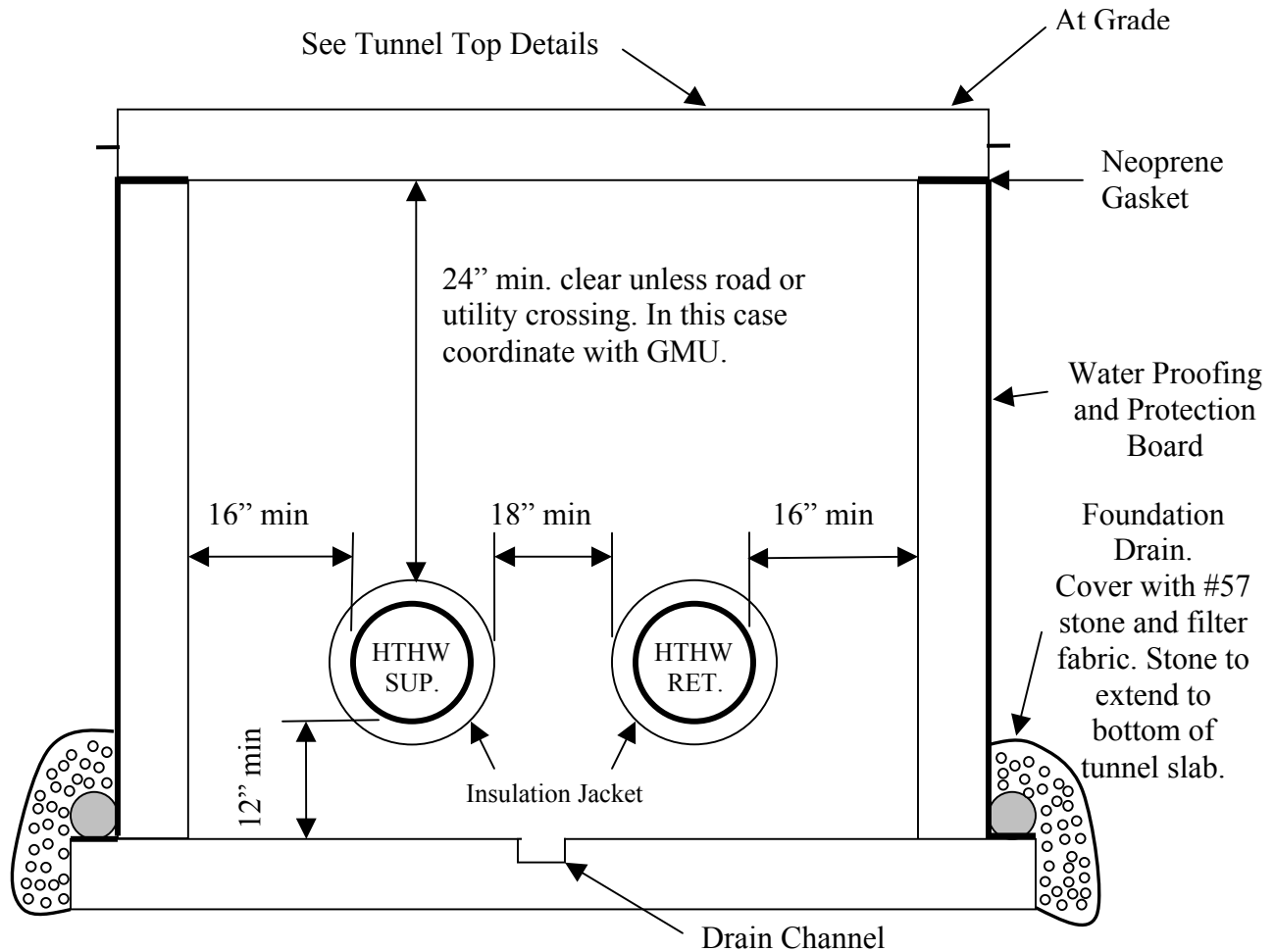

Notes:

1. Manholes, tunnel and piping to be designed by a Virginia registered Professional Engineer.
2. Construct tunnel and tops for H-20 loading.
3. Design tunnel and piping with as little abrupt elevational and lateral direction change as possible to avoid additional anchorage and expansion joints. Tunnel height can vary with site contour but height shall not exceed 8'. Tops at grade unless precluded by abrupt grade changes, road crossing or other obstruction.
4. Provide floor drains in tunnel if necessary. Otherwise grade drain channel to manhole.
5. Lifting lugs for tunnel top removal shall be located on the sides of the tunnel top, see Tunnel Top Detail.
6. For Expansion Joints, Ball Joints and Anchorage provide hatch access with cover. Hatch to be 4' x 3' min. clearance.

HTHW Tunnel Top Details:

[BACK to Div. 15](#)

**\*\* NOT TO SCALE \*\***

[BACK to Div. 3](#)

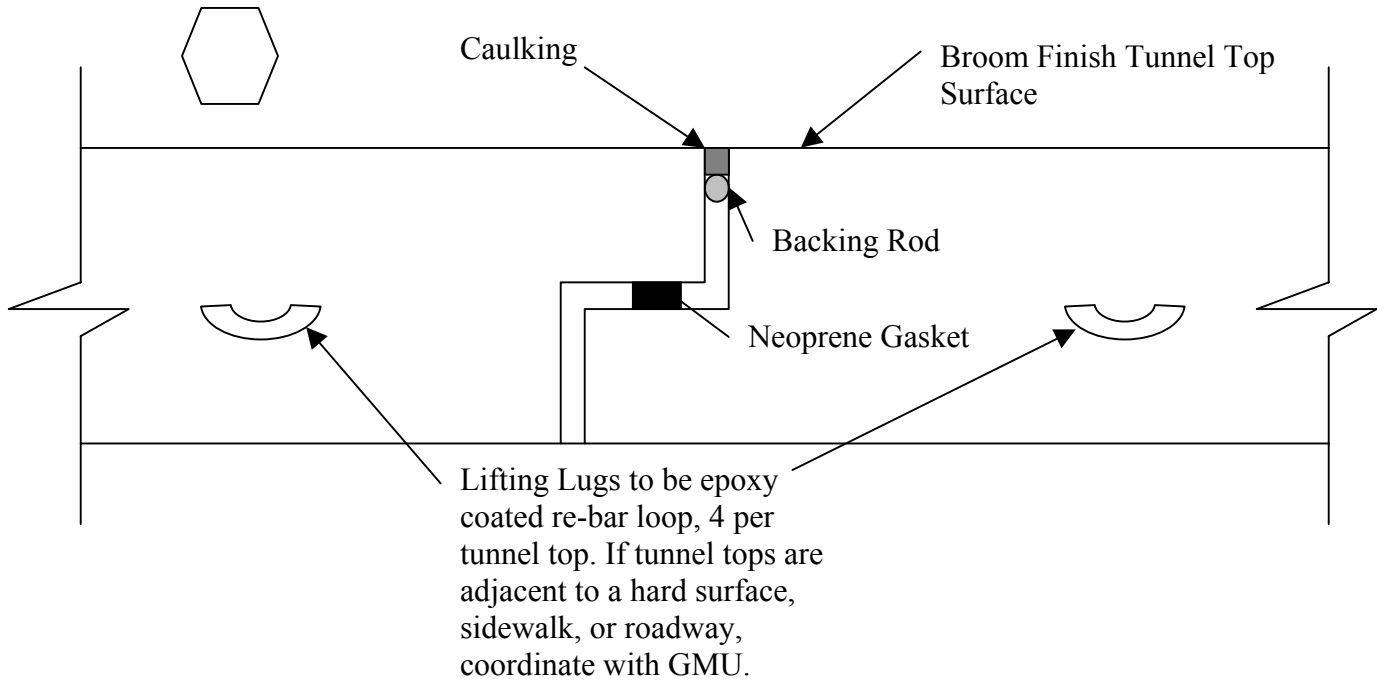

Notes:

1. Construct tunnel and tops for H-20 loading.
2. Tops at grade unless precluded by abrupt grade changes, road crossing or other obstruction.
3. Tunnel tops not to exceed 4,500 pounds each.

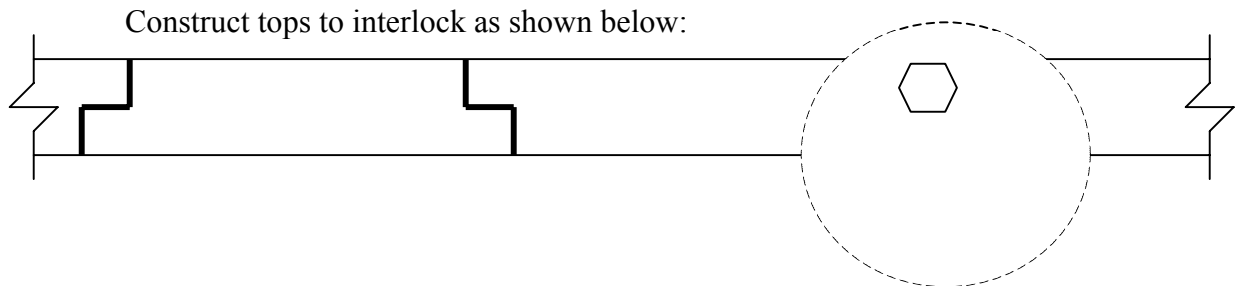

HTHW Manhole Detail

[BACK to Div. 15](#)

**\*\* NOT TO SCALE \*\***

[BACK to Div. 3](#)

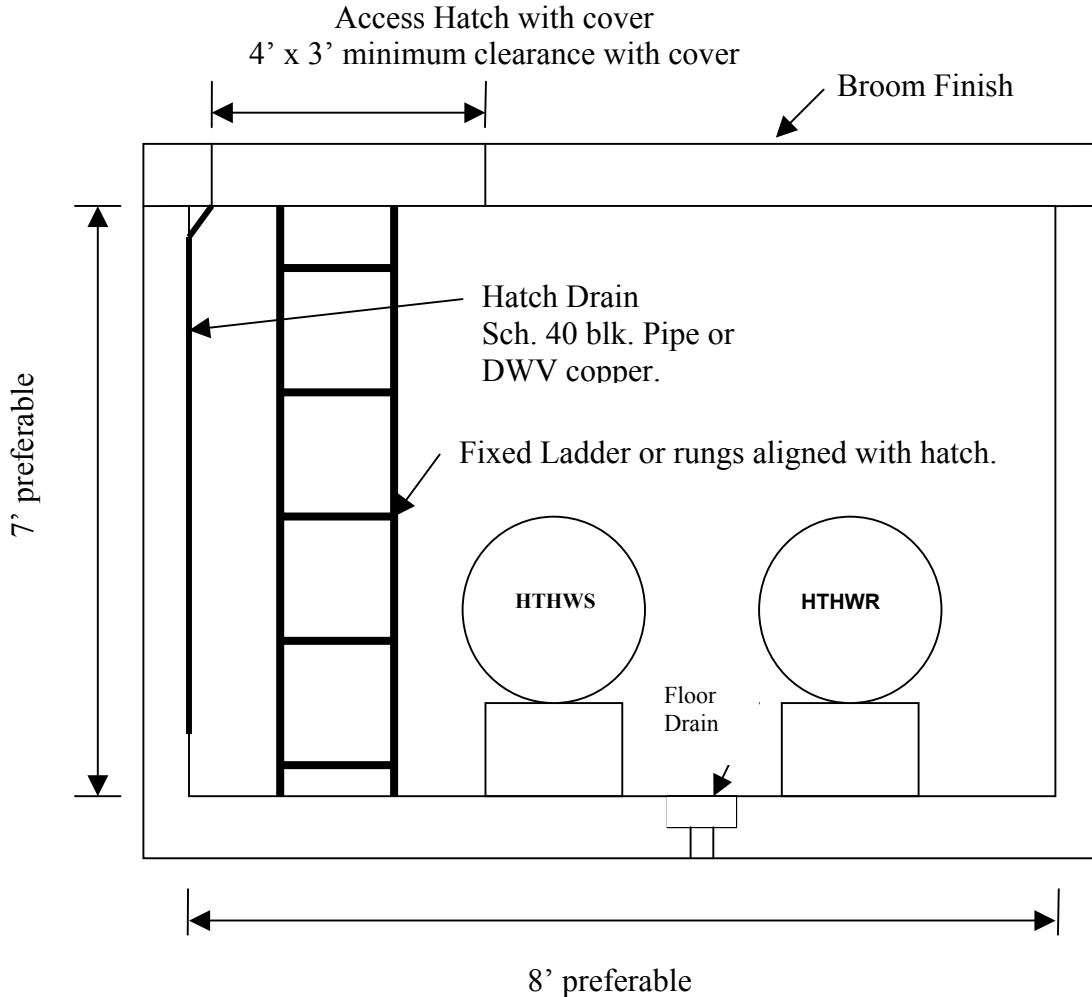

**Notes:**

1. Construct Manhole for H-20 loading.
2. Manholes are required at building take-offs and valve locations only.
3. Floor drain to be piped to Storm Sewer.
4. At lowest Manhole in the piping run include HTHWS & R drains piped to a tempering tank, to be discharged into sanitary sewer.
5. If a sump pump is required, power to the sump pump to be connected to emergency power.
6. Include a three-valve combination on the supply and return for each building take-off to accommodate back-feed capability. See below:

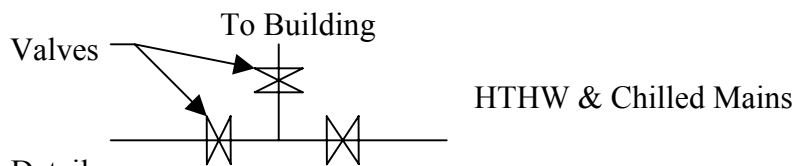

HTHW Main, Preferred Anchorage Details

**\*\* NOT TO SCALE \*\***

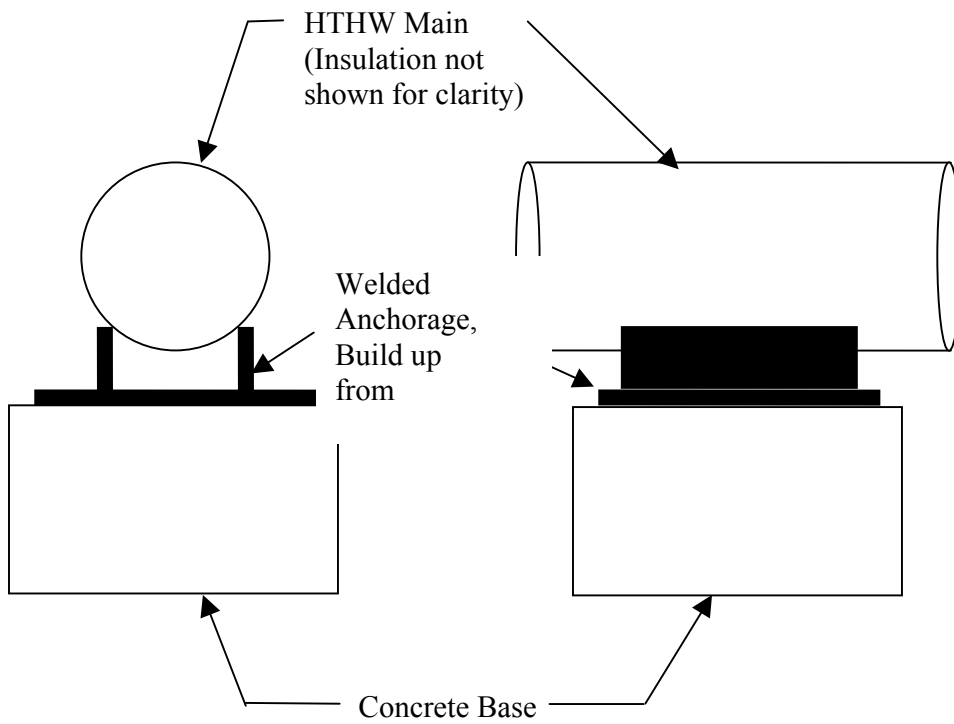

Preferred Corner Anchorage:

**\*\* NOT TO SCALE \*\***

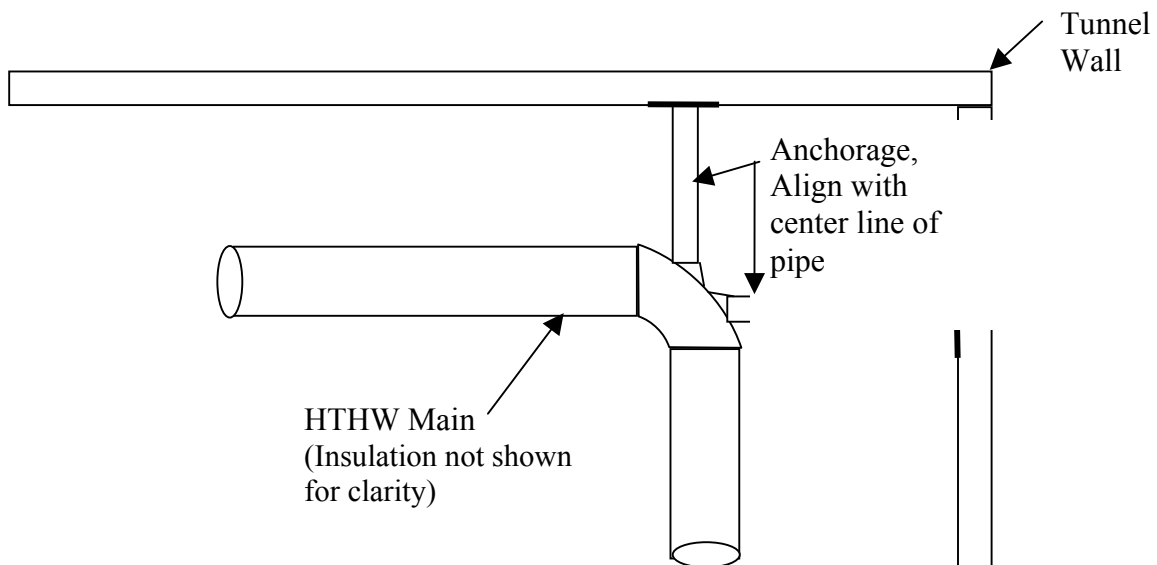

# THE RIBBON® RACK by brandir

## IMPORTANT CONSIDERATIONS

**COLORS (Painting/Coating)**—Painting or coating the rack will result in a maintenance problem, as no coating will withstand the abuse of the bicycles. Powder coating cannot be maintained; an enamel finish will chip. A A A RIBBON® Rack Co. has the best solution where color is essential. Please contact us to find out how to achieve an appropriate color with a minimum of maintenance.

**MATERIALS**—Steel tubing or aluminum are not suitable materials for a bicycle rack. Pre-galvanized material will flake and crack during manufacture. A A A RIBBON® Rack Co. uses heavy-duty steel pipe, hot-dipped galvanized after fabrication to provide security and durability.

**MANUFACTURE**—Hydraulic bending with a mandrel, as used by A A A RIBBON® Rack Co. insures smooth and aesthetic curves on The RIBBON® Rack. Press bending leaves an indentation, other methods flatten outer and crimp inner curves.

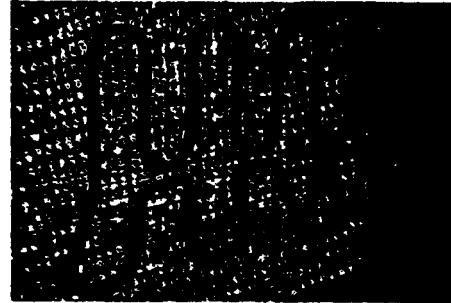

Model RB 09

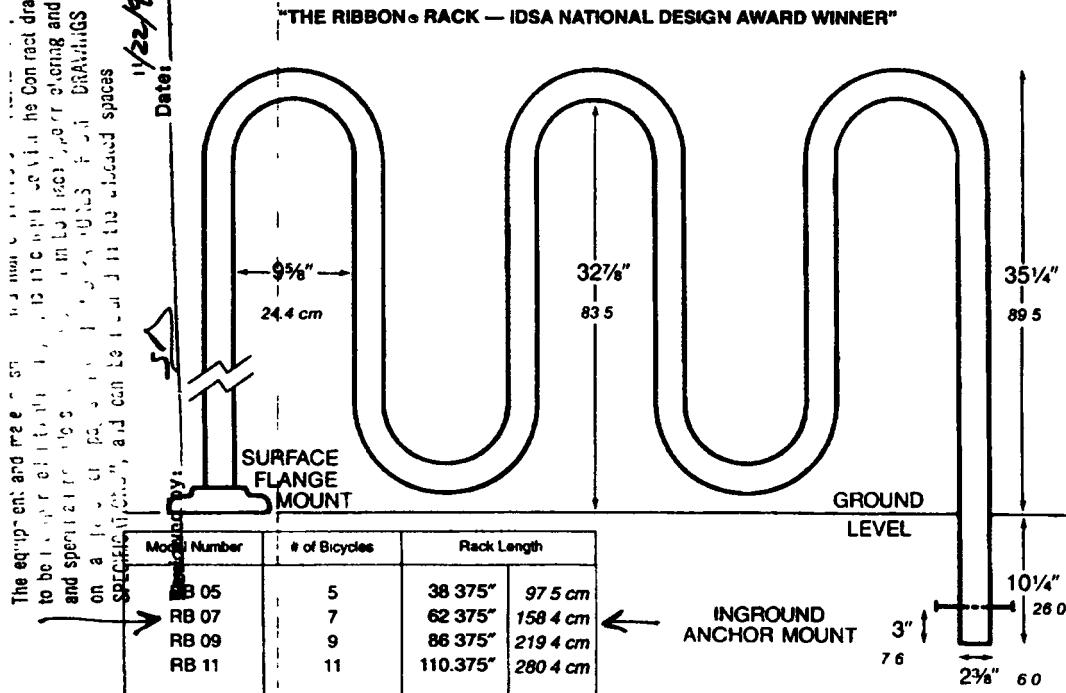

The equipment and materials used in the construction of this rack are designed to be used in a variety of environments. It is not intended for use in corrosive or highly abrasive environments. The rack is designed to be used in a variety of environments and can be used in the indicated spaces.

### General

'RIBBON' and the Brandir International Inc logo are trademarks of Brandir International Inc used exclusively by A A A RIBBON® Rack Co.

Delivery time Six weeks or sooner from receipt of order

For prices and information contact  
**A A A RIBBON® RACK CO., INC**  
 Division of  
**BRANDIR INTERNATIONAL, INC**  
 521 Fifth Avenue 17th Floor  
 New York, NY 10175 USA  
 212 512 5500 Fax 212 512 5812

### Specifications

All standard units made from ASTM A53 SCHEDULE 40 steel pipe (2 3/75" OD x 154 wall) hydraulically bent with a mandrel, hot-dipped galvanized after fabrication

Installation methods  
 inground anchor mount (standard)  
 freestanding mount (optional & surface flange mount) extra

The RIBBON® RACK is available in ASTM A312 SCHEDULE 40 TP 304 stainless steel, satin #4 finish (optional and extra)

### Specifying / Estimating / Ordering

Please use the following notation

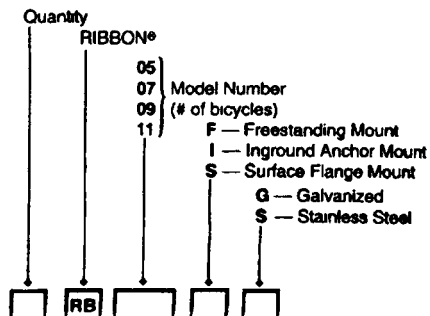

Back cover photo / Joanne Gere

Printed in U.S.A.

© 1995 Brandir International Inc

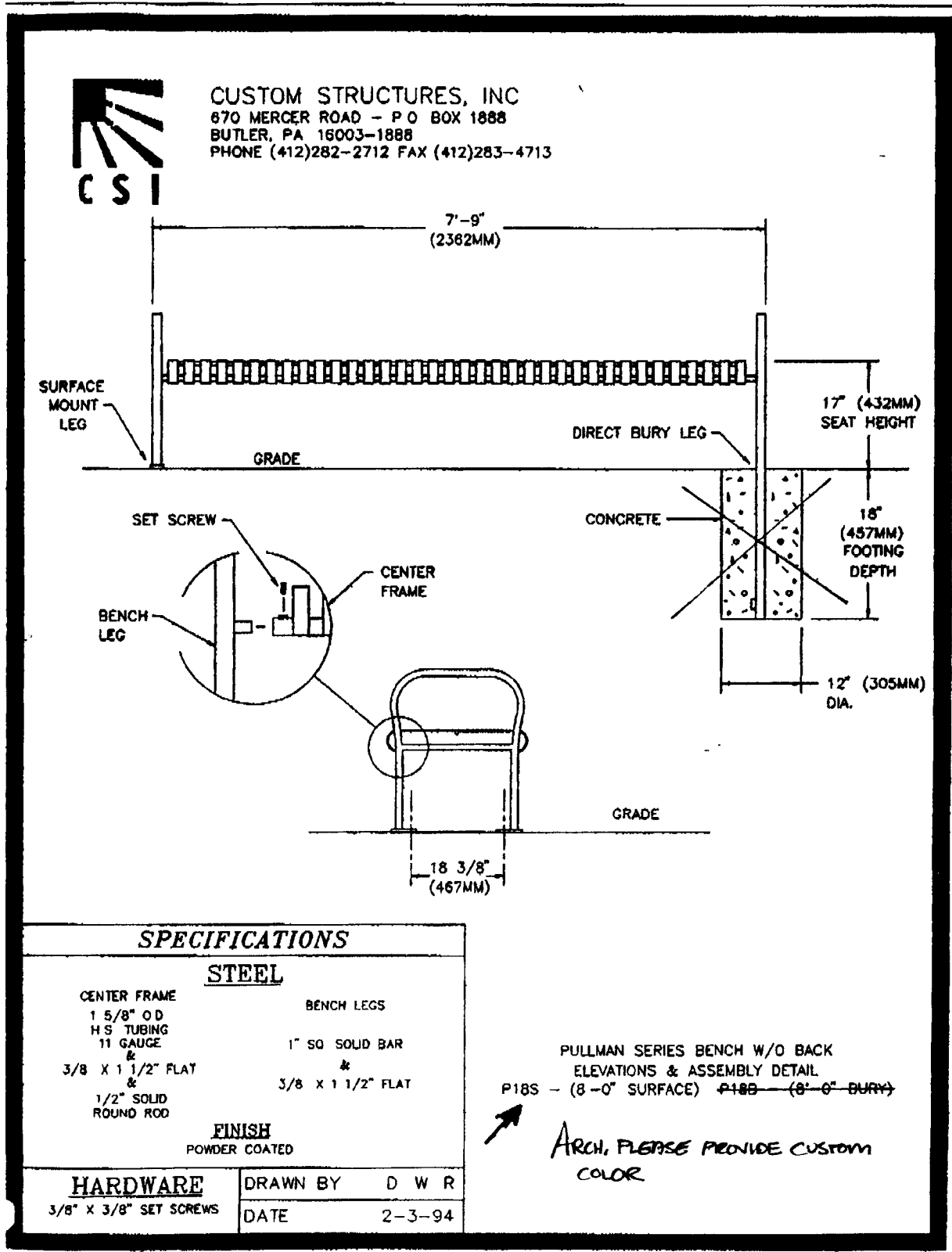



Outdoor Benches, Arlington Campus

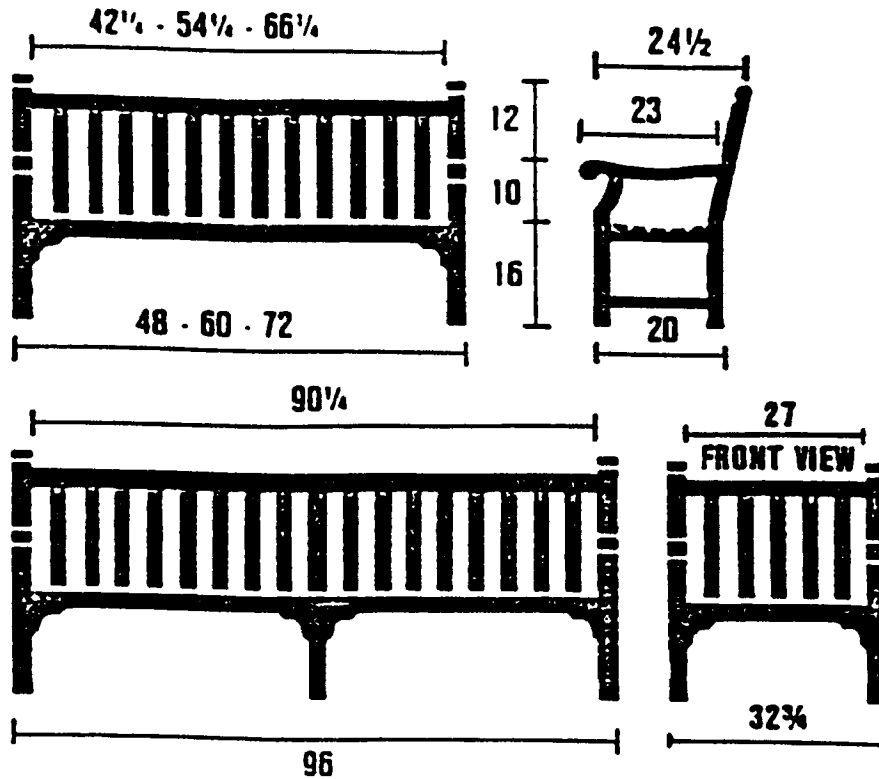

All dimensions are shown in inches.

The equipment and materials shown and marked in this submittal is to be incorporated into this Project in compliance with the General Conditions and specifications unless otherwise shown in bold face type or lettering and listed on a page or pages headed "DEPARTURES FROM DRAWINGS AND SPECIFICATIONS", and can be installed in the allocated spaces.

Reviewed by: *Sei Thomas* Date: *8/17/94*  
2870-1

|  |                  |       |             |
|--|------------------|-------|-------------|
|  <b>Victor Stanley, Inc.</b><br>"DUNKIRK" | Date <i>6-85</i> | Scale | SHT. ' OF ' |
|  | Dwn.             | Rev.  |             |

P.O. Box 144 (301) 855-8300  
Dunkirk, Maryland 20754

**Victor Stanley, Inc.** P.O. DRAWER 330 - DUNKIRK, MD 20754  
 (301) 855-8300 FAX (410) 257-7579

PG 1 OF 1

DATE 11/29/93 VIEWS-5  
 DRAWN G R REV. 5/06/94

**PRODUCT SPECIFICATIONS**

**Ironsites  
 -42 (32 GAL.)  
 Bethesda Series)  
 Tilter Receptacle**

Span steel concave lid  
 Vinyl coated aircraft steel cable  
 Steel cable end is looped around attachment bracket and crimped in place  
 Steel cable attachment brackets  
 5/8" steel rod  
 1/4" x 2 1/2" steel bar  
 Fully welded joints throughout  
 Center anchor brace made from 3" structural steel channel  
 3/8" x 1" steel bar (42)  
 3/8" x 3" solid steel bar base supports  
 Steel adjusting feet (3/8" diameter threaded shaft) with rubber feet  
 Includes 32 gal high density plastic liner not shown in view  
 3/4" spacing between bars  
 Center anchor bolt hole with clearance for 1/2" bolt size  
 All finished components are cleaned, etched, phosphatized and electrostatically powder coated with TGIF polyester powder coatings  
 All of our products are manufactured to the highest possible standards, using the finest materials available

**SIDE VIEW**

25  
 39-1/2  
 19  
 23-3/4

**PERSPECTIVE**

**CUT SECTION**

28-1/8  
 22-1/2

**TOP VIEW**

All specifications are subject to change. Please contact factory for details.

Copyright 1994  
 Victor Stanley, Inc. Patent # B304,253  
 All Rights Reserved. Patent # B304,632

[BACK to Div. 3](#)

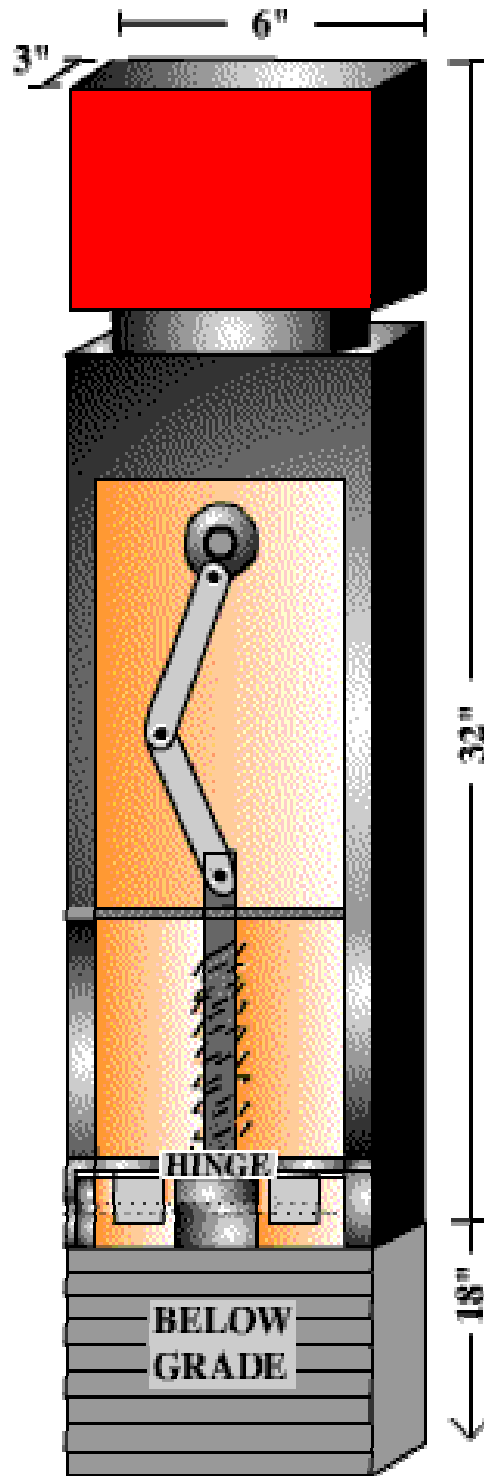

[BACK](#)